

Front Fork

RXF36 m.2

Workshop Manual - Chassis and Air Spring 100 h



SAFETY PRECAUTIONS

General Warnings

Note!

When working with the Öhlins product, always read the Vehicle Service Manual.

Note!

The shock absorber/front fork/steering damper is an important part of the vehicle and will affect the stability.

Note!

Read and ensure you understand the information in this manual and other technical documents provided by Öhlins, before using the product.

Note!

Öhlins Racing AB can not be held responsible for any damage to the shock absorber/front fork/steering damper, vehicle, other property or injury to persons, if the instructions for mounting, usage and maintenance are not followed exactly.

Warning!

After installing the Öhlins product, take a test ride at low speed to ensure your vehicle has maintained stability.

Warning!

If the suspension makes an abnormal noise, or the function is irregular, or if you notice any leakage from the product, stop the vehicle immediately and return the product to an Öhlins Service Centre.

Warning!

The product warranty shall only apply if the product has been operated and maintained in accordance with recommendations in this manual. If you have any questions regarding usage, service, inspection and/or maintenance please contact Öhlins.

Note!

Before working on the product make sure that the vehicle is washed and cleaned properly. Do not use alcobased products on the outside or inside of the product.

Product Specific Warnings

Warning!

This product was developed and designed exclusively for a specific vehicle model and shall only be installed on the intended vehicle model in its original condition as delivered from the vehicle manufacturer.

Warning!

This product is pressurized. Do not open, service or modify this product without proper education (authorized Öhlins dealer/distributor) and proper tools.

Caution!

Do not use a pressure washer or a power washer when cleaning the fork.

SAFETY SYMBOLS

In this manual, mounting instructions and other technical documents, important information concerning safety is distinguished by the following symbols:



The Safety Alert Symbol means: Warning! Your safety is involved.

Warning!

The Warning Symbol means: Failure to follow warning instructions can result in severe or fatal injury to anyone working with, inspecting or using the shock absorber/front fork, or to bystanders.

Caution!

The Caution Symbol means: Special precautions must be taken to avoid damage to the shock absorber.

Note!

The Note Symbol indicates information that is important regarding procedures.

© Öhlins Racing AB. All rights reserved.

Any reprinting or unauthorized use without the written permission of Öhlins Racing AB is prohibited.

TABLE OF CONTENTS

Tools	3
Overview	3
Service Kit Contents	4
Chassis 100-H Service	5
Air Spring Cartridge 100-H Service	8

RXF36 M.2 100-HOUR SERVICE

Tools

1	19245-01	Multi clamp TTX18
2	19246-02	Seal installation tool
3	-	Cassette locking tool

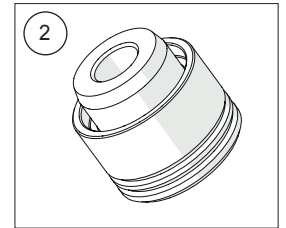
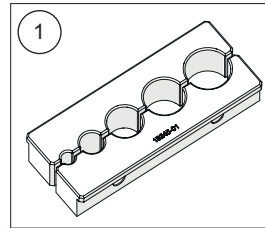

Oil, grease, thread locker and sealant

Fork lubrication fluid	01336-01 - Renep CGLP 68 Fork lube 1L
Air spring lubrication fluid	01337-06 - Renep CGLP 220 Air spring lube 0.6L
Function grease	01338-22 - Renolit SI 410 M Silicone grease 225g
Assembly grease	Slickoleum / Buzzy's Slick Honey

Overview - General layout

1 Chassis

2 Air Spring Cartridge

3 Damper Cartridge

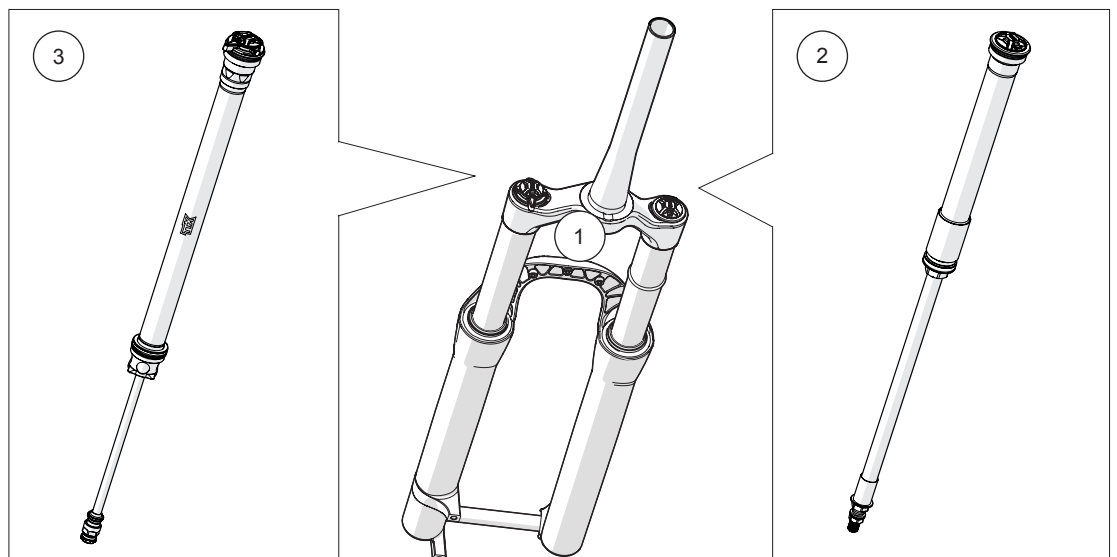

RXF36 M.2 100-HOUR SERVICE

Service Kit Contents

1	18850-12	Service Kit Air Spring 100h RXF34/RXF36 *
2	18880-07	Service Kit Chassis SKF RXF36 **

*The following service kit, 18850-02 can also be used.

**The following service kits, 18880-01/03 can also be used.

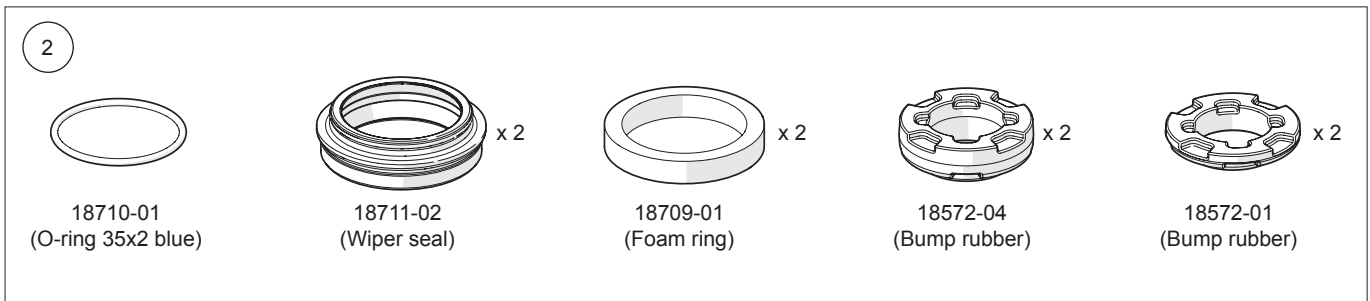
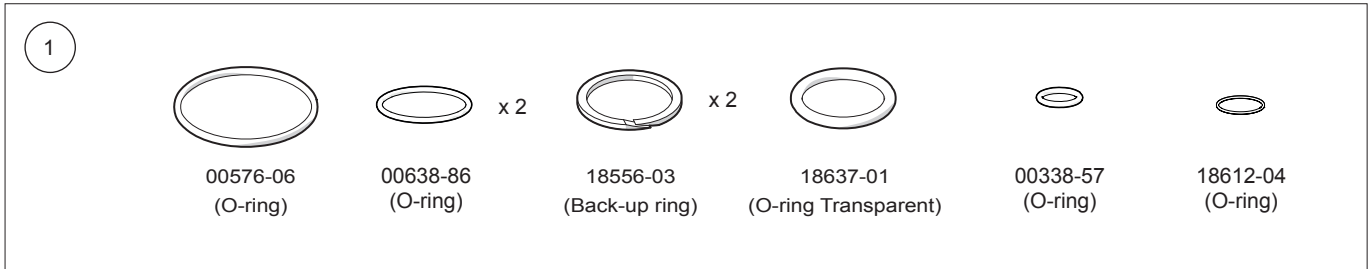

RXF36 M.2 100-HOUR SERVICE

Chassis 100-Hour Service

We recommend using a bike stand to clamp the steering tube when working on the fork.

Note!

Record the rebound adjuster setting and the pressure in the positive air chamber and ramp up chamber before service.

1. Thoroughly clean the outside of the fork from dirt or grit.
2. Release the air from the positive air chamber at the top and the ramp up chamber at the bottom.
3. Use a 14 mm wrench to hold the rebound adjuster knob steady. With a 2 mm hex key remove the screw and the knob.
4. Remove the nut by using a socket wrench with a 14 mm socket.
5. Use a socket wrench to remove the nut on the lower air valve. 12 mm nuts have washer 14 mm have not.
6. Slide the lower legs off the stanchions.
7. Drain the lower legs of all fluids.

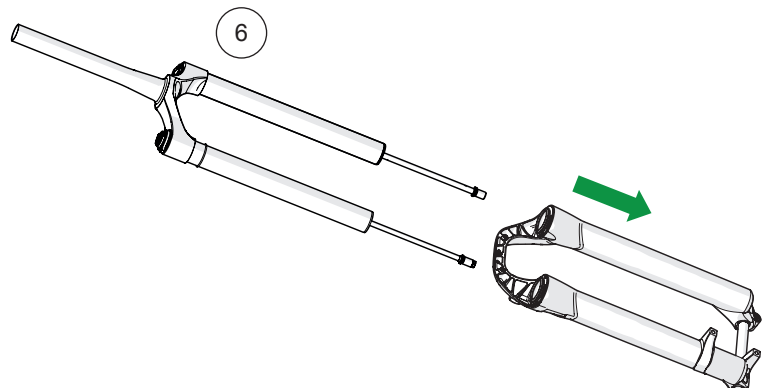
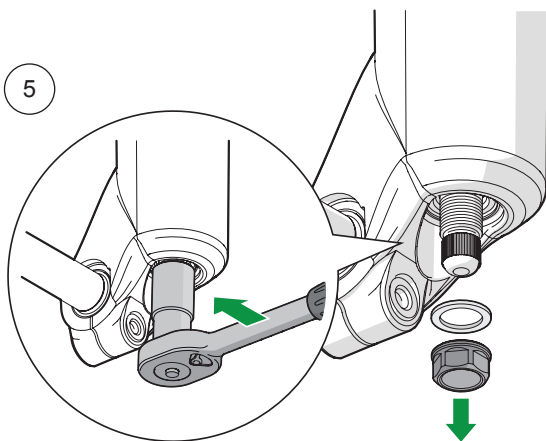
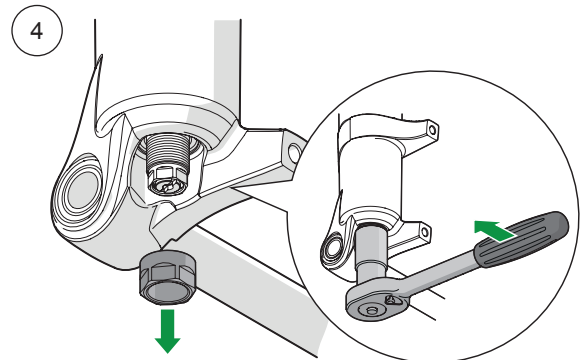
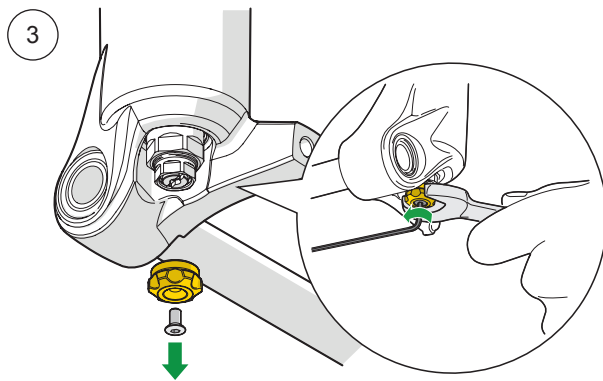
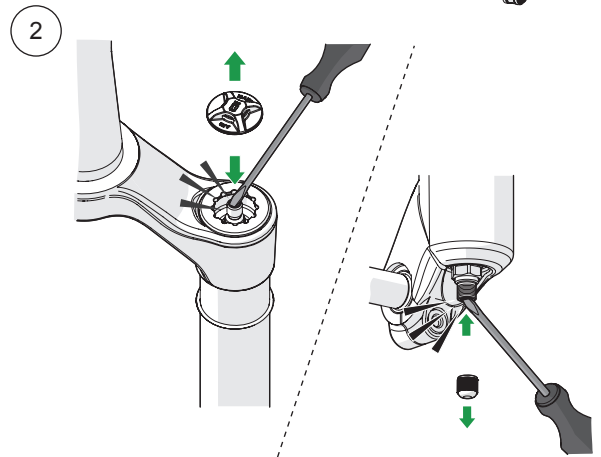
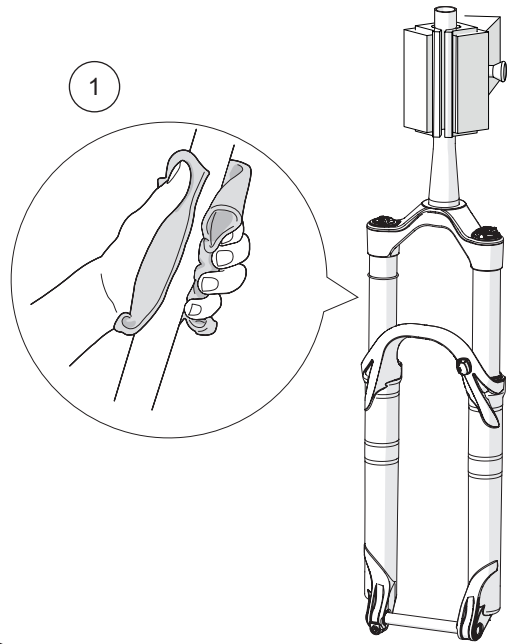

RXF36 M.2 100-HOUR SERVICE

8. Use tweezers to cautiously remove the old foam rings in the lower legs.

9. Carefully remove the old bump rubbers from the lower legs. Protect lowers and seal surfaces from scratches.

10. Use a screwdriver or similar to remove the old wiper seals.

Note!

Be careful not to scratch the bushings.

11. Use a rag wrapped around a long rod or similar to clean the insides of the lower legs.

12. Carefully clean the wiper seal and foam ring areas using disc brake cleaner and a paper cloth or rag to remove old suspension fluid and dirt.

13. Reinsert new bump rubbers, 18572-01 (For all RFX36 forks except coil 170mm) or 18572-04 (Only for RFX36 coil 170mm) into the lower legs. Use a long rod or similar to carefully put them in place.

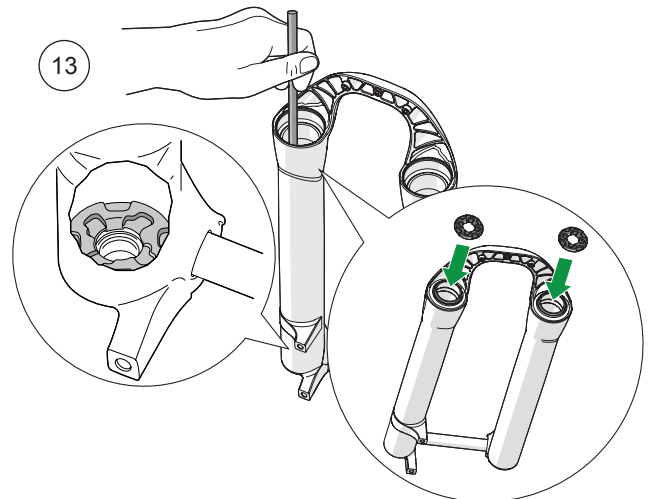
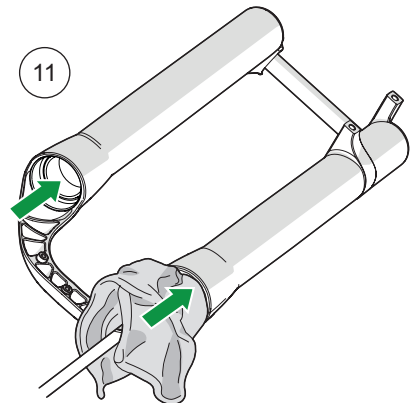
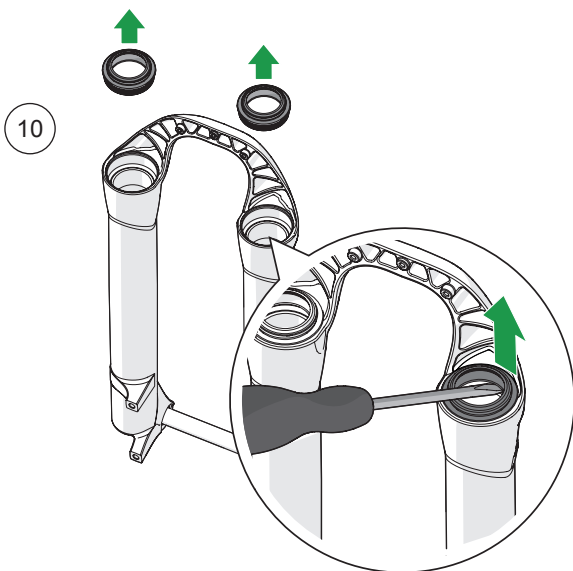
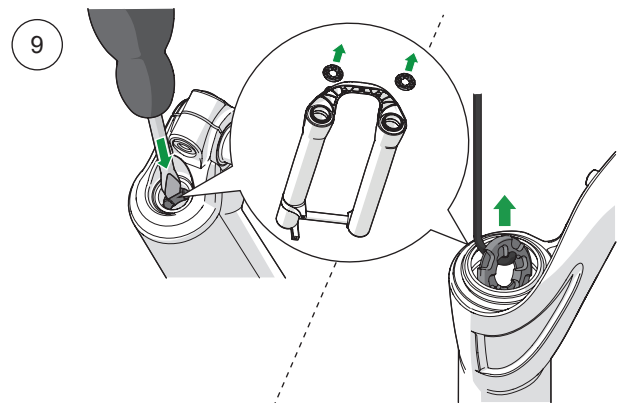
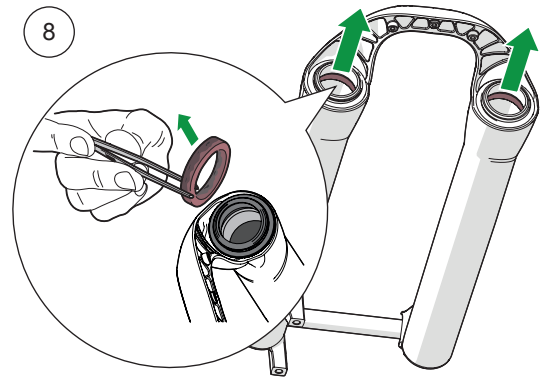

RXF36 M.2 100-HOUR SERVICE

14. Reinsert new wiper seals into the lower legs. Use the wiper seal tool and a soft hammer to put them in place.

15. Apply a thin layer of function grease to the inner surfaces of the wiper seals.

16. Soak the foam rings in fresh fork lubrication fluid.

17. Use tweezers or similar to carefully reinsert the soaked foam rings into the lower legs. Check that they are mounted correctly and not twisted.

18. Remove the old sag o-ring.

19. Install a new sag o-ring from the service kit.

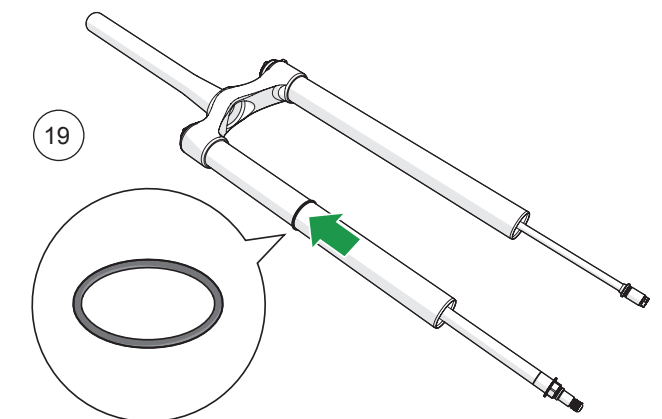
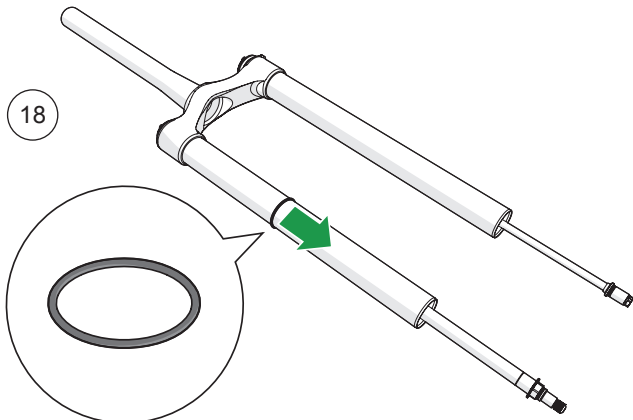
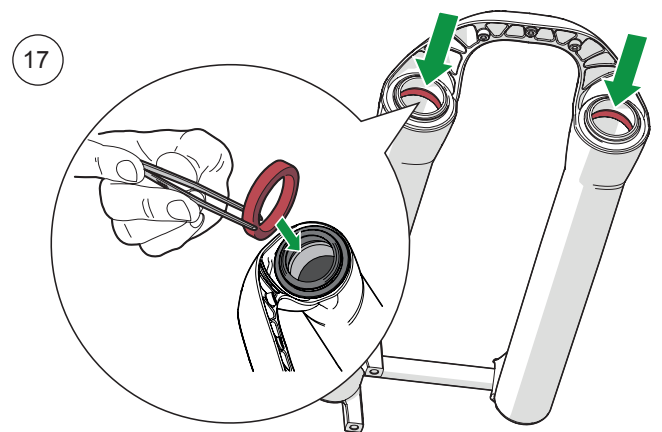
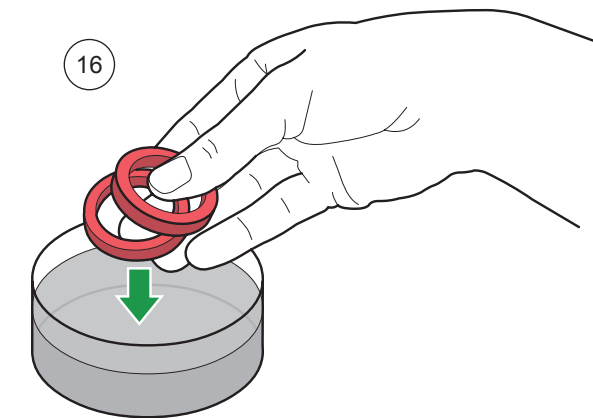
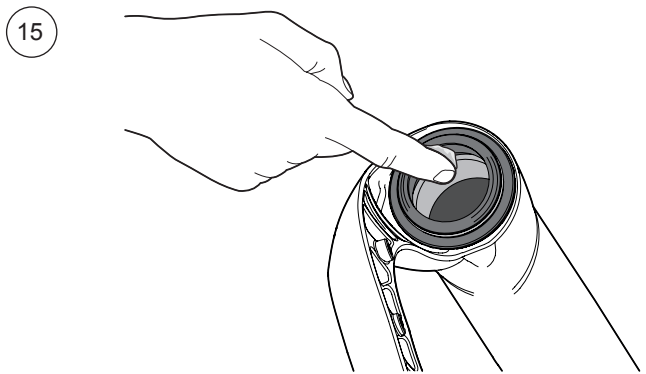
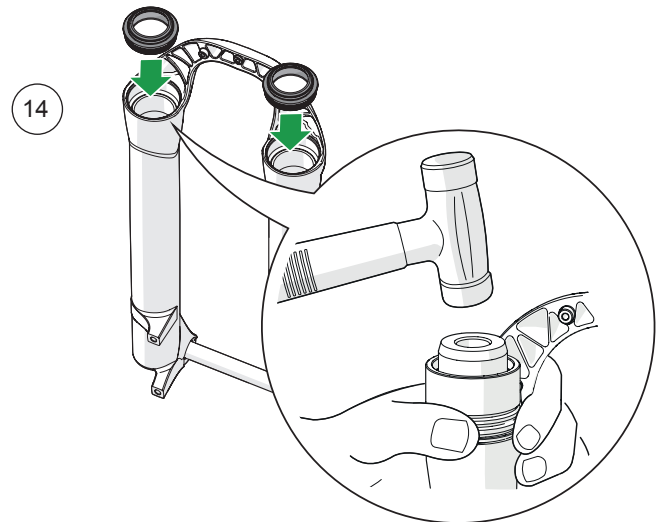

RXF36 M.2 100-HOUR SERVICE

Air Spring Cartridge 100-Hour Service

Note!

Clean all parts using disc brake cleaner and a rag to remove dirt, old grease and thread sealant before reassembling. Lubricate new o-rings/x-rings etc. with fresh assembly grease if no other grease is specified.

Note!

Use a vise and the appropriate multiclamp when servicing the front fork.

20. Remove the positive air chamber knob. Use a socket wrench with a cassette locking socket to loosen the air spring.

21. Slide the air spring off the stanchion tube.

22. Use a 19 mm wrench to loosen the seal head. Slide the cylinder tube off the air spring.

23. Remove the old o-ring (00576-06) from the top cap.

24. Install a new o-ring (00576-06) on the top cap.

25. Remove the old o-ring from the base cap.

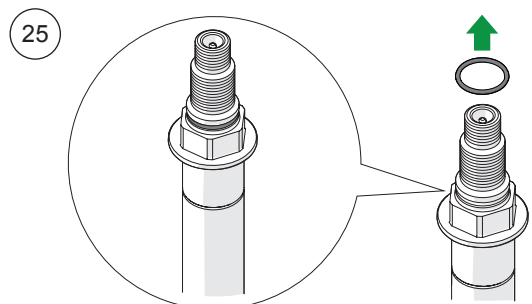
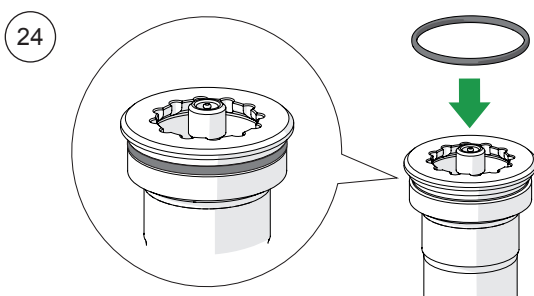
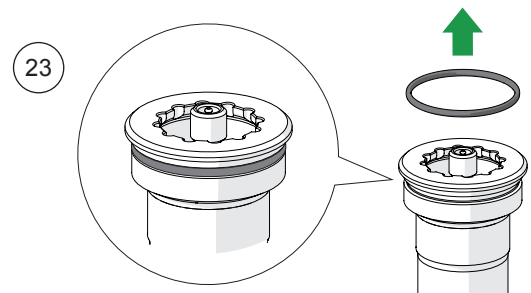
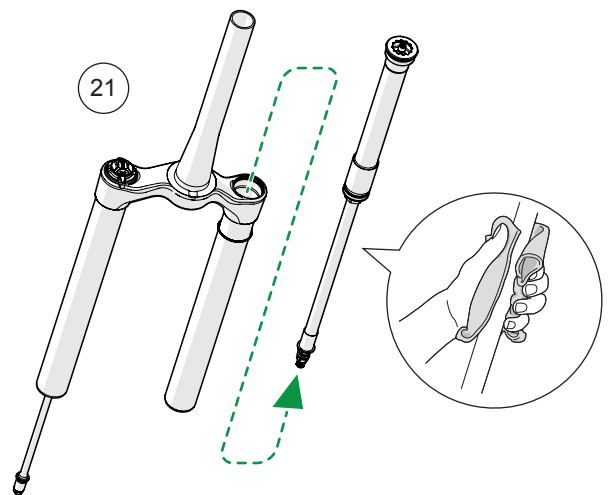
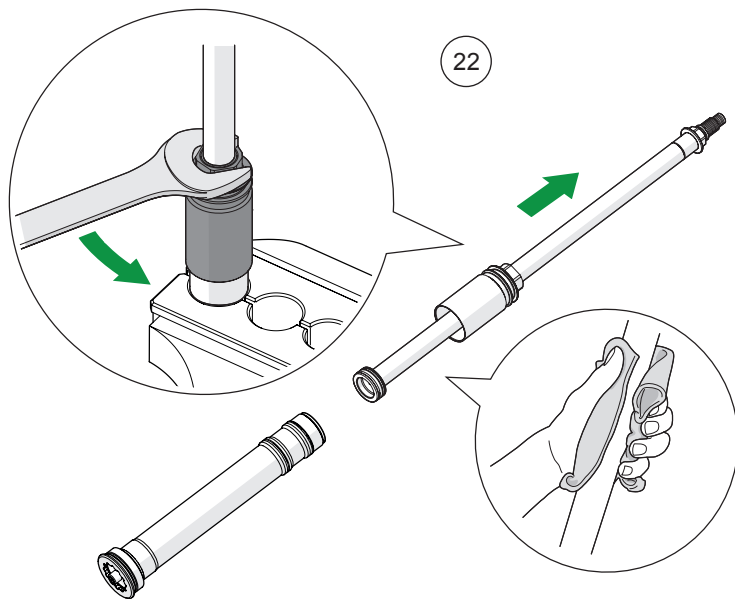
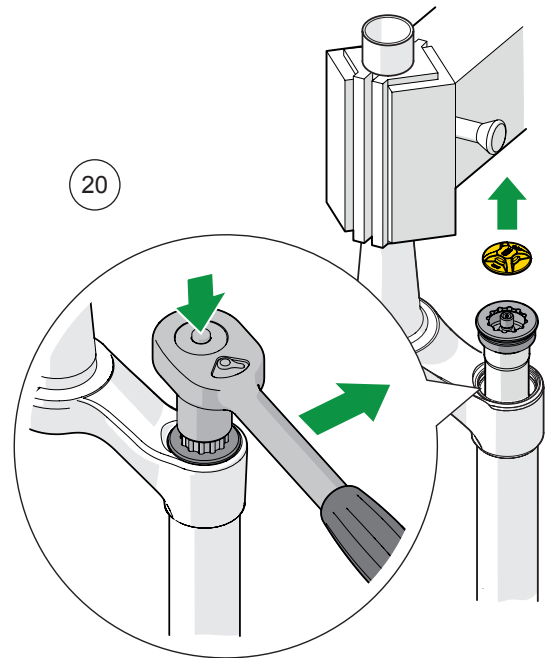

RXF36 M.2 100-HOUR SERVICE

26. If the base cap is silver and M10 install o-ring (18612-04). If it is gold and M12 install 00338-57.

Note!

Only perform steps 9-13 if leakage from the main chamber is suspected.

27. Remove the two old o-rings (00638-86) from the upper air chamber cylinder tube.

28. Install two new o-rings (00638-86) on the upper air chamber cylinder tube. Apply assembly grease on o-rings.

29. Remove the old o-ring (18637-01) from the piston.

30. Remove the the two old back-up rings (18556-03).

31. Carefully clean the piston using disc brake cleaner and a paper cloth or rag to remove old grease and dirt.

32. Install a new o-ring (18637-01) on the piston between the back-up rings.

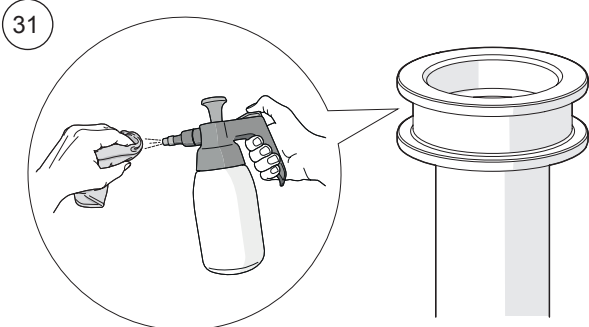
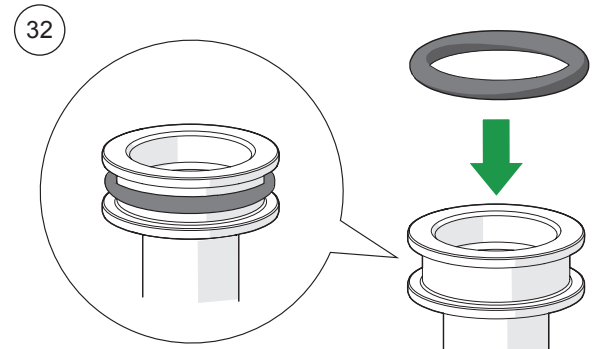
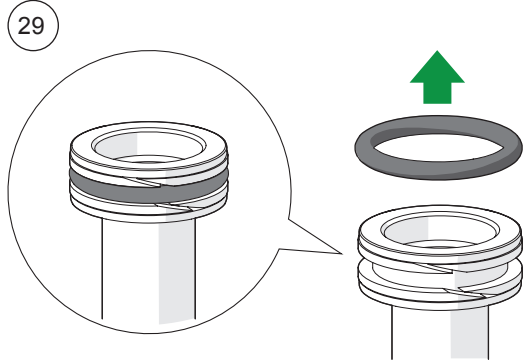
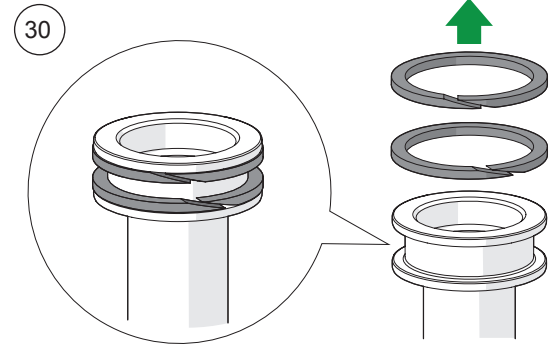
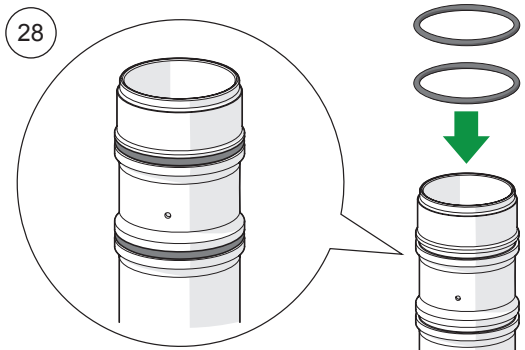
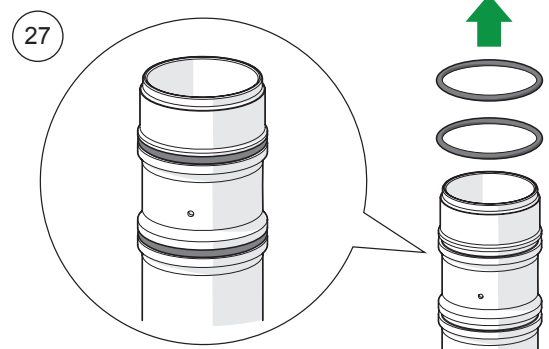
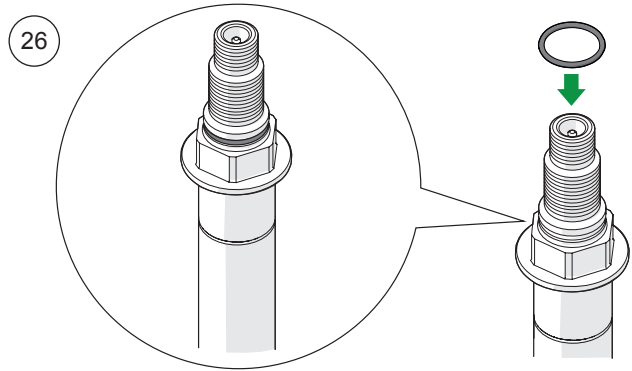

RXF36 M.2 100-HOUR SERVICE

33. Install two new back-up rings (18556-03) on the piston.

34. Apply 2 ml of function grease at the inside of the cylinder tube (smeared around). Add 0,5 ml of air spring lubrication fluid distributed on top of the grease.

35. Apply a thin layer of function grease on the o-ring and the back-up rings on the main piston.

36. Insert main piston in the cylinder tube and add 0,5 ml of air spring lubrication fluid inside the cylinder tube. Slide the seal head onto the cylinder tube and screw them together hand-tight.

37. Use a 19 mm torque wrench to tighten the seal head to 10 Nm.

38. Reinstall the Air spring cartridge into the stanchion tube.

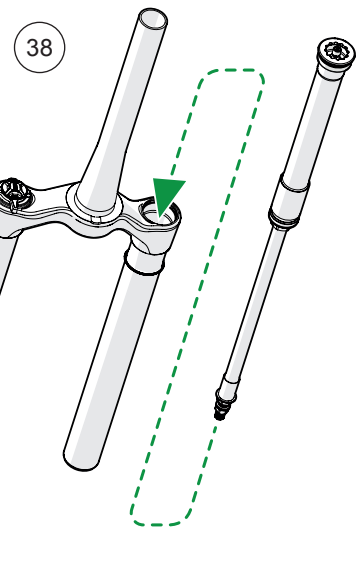
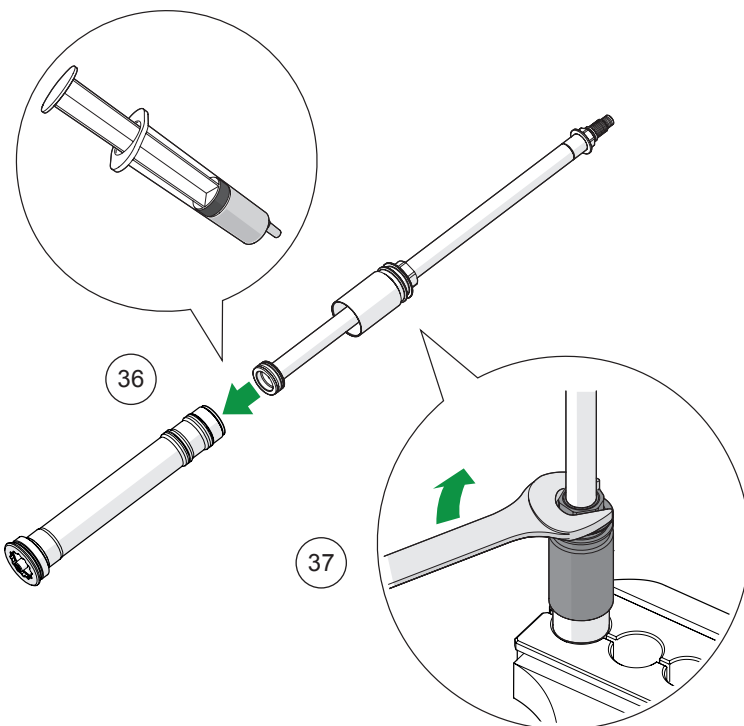
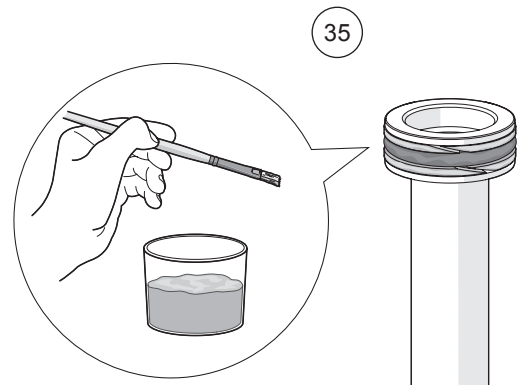
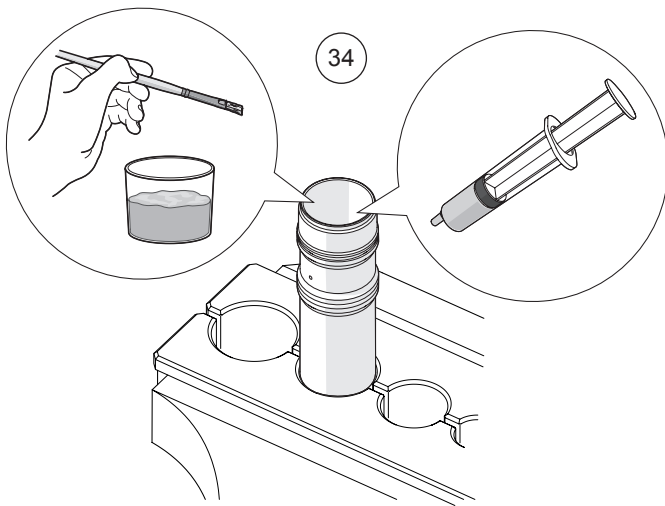
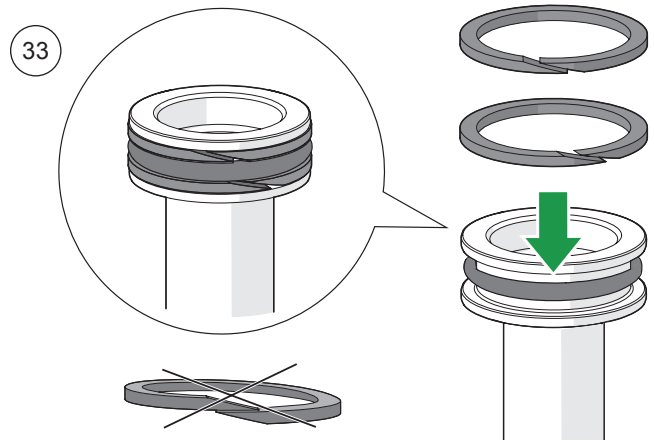

RXF36 M.2 100-HOUR SERVICE

39. Use a torque wrench with a cassette locking socket to tighten the top cap to 32 Nm.

40. Clean the stanchion tubes with a paper cloth or soft rag.

41. Reinstall the stanchion tubes into the lower legs.

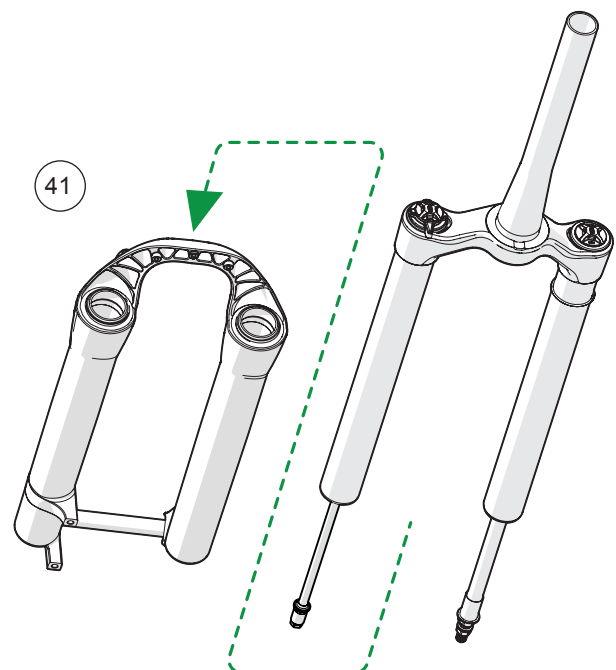
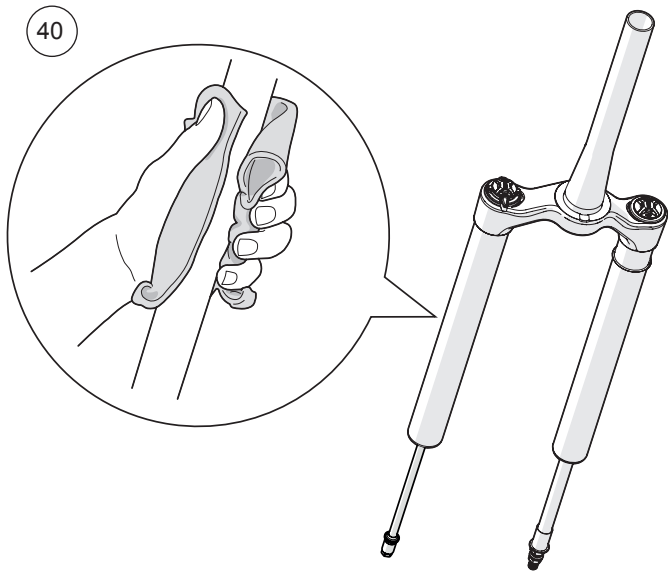
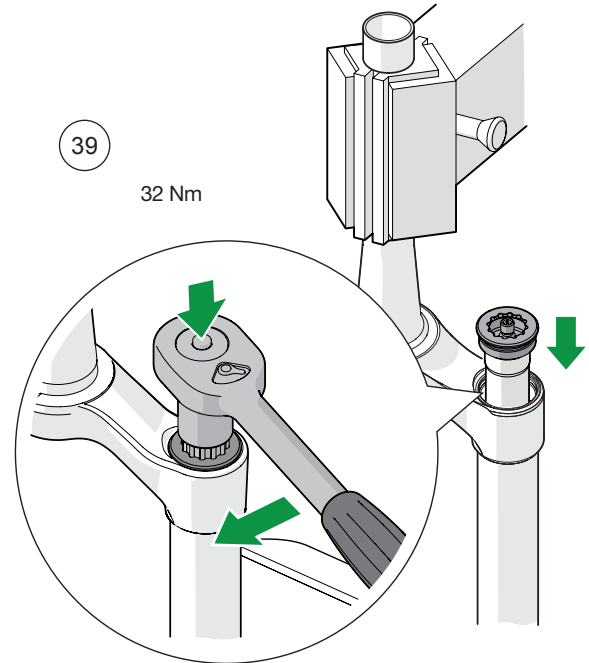

RXF36 M.2 100-HOUR SERVICE

42. If the seal head is blue and the piston rod end is golden use 10 ml of fork lubrication fluid in spring and damper fork leg. For all other forks use 5 ml of fork lubrication fluid in spring and damper fork leg. It is important not to overfill as that will affect fork performance.

43. Refit the lower nuts and washer on the valve side if nut is M10. Tighten to 10 NM. Reinstall the rebound adjuster nut, knob and screw.

44. Inflate the ramp up chamber (A) at the bottom and then the positive air chamber (B) at the top to the desired air pressures.

⚠ Caution!

Inflate the ramp up chamber (A) at the bottom first.

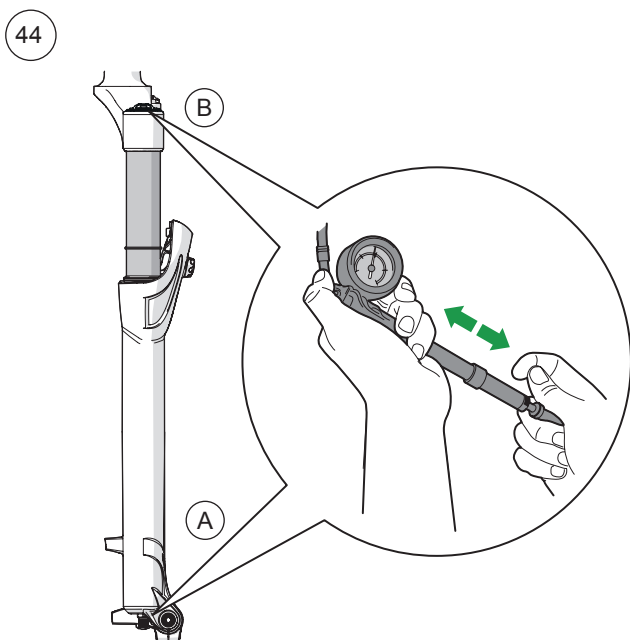
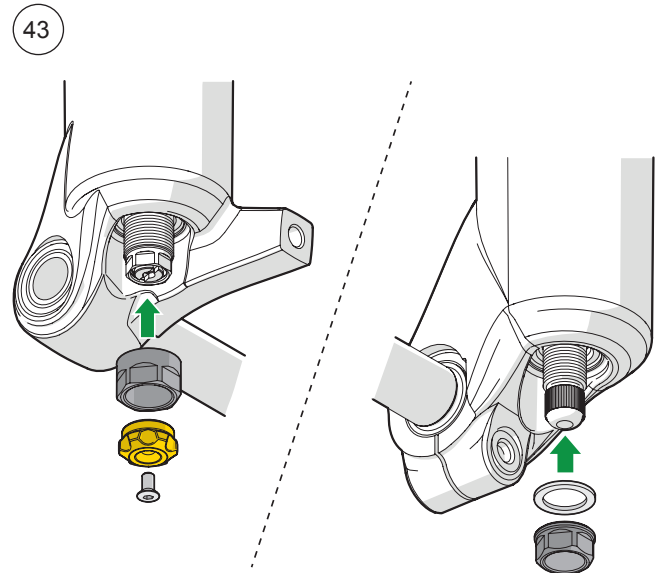
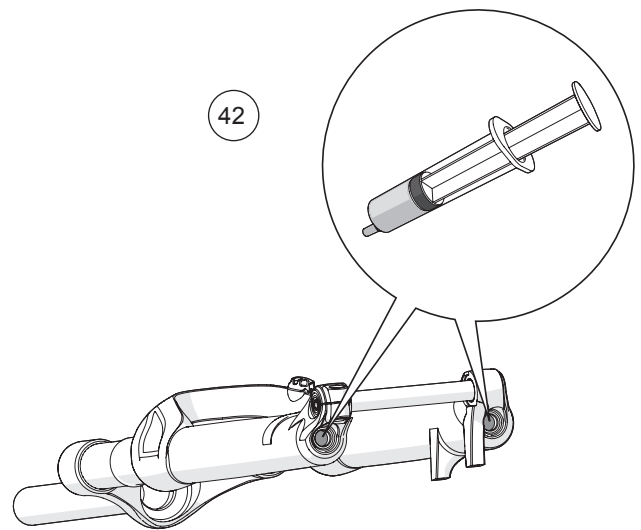

RXF36 M.2 100-HOUR SERVICE

Your Öhlins retailer:

Öhlins Racing AB
Box 722
SE-194 27, Upplands Väsby
Sweden

Phone: +46 (0)8 590 025 00
Fax: +46 (0)8 590 025 80
www.ohlins.com



www.ohlins.com