

DH38 Race Fork

FG38xx 19xx

Workshop Manual - 50 h Service



ADVANCED SUSPENSION TECHNOLOGY

SAFETY PRECAUTIONS

General Warnings

👁 Note!

When working with the Öhlins product, always read the Vehicle Service Manual.

👁 Note!

The front fork is an important part of the vehicle and will affect the stability.

👁 Note!

Read and ensure you understand the information in this manual and other technical documents provided by Öhlins, before using or working on the product.

👁 Note!

Öhlins Racing AB can not be held responsible for any damage to the shock absorber/front fork/steering damper, vehicle, other property or injury to persons, if the instructions for mounting, usage and maintenance are not followed exactly.

⚠ Warning!

After installing the Öhlins product, take a test ride at low speed to ensure your vehicle has maintained stability.

⚠ Warning!

If the suspension makes an abnormal noise, or the function is irregular, or if you notice any leakage from the product, stop the vehicle immediately and return the product to an Öhlins Service Centre.

⚠ Warning!

The product warranty shall only apply if the product has been operated and maintained in accordance with recommendations in this manual. If you have any questions regarding usage, service, inspection and/or maintenance please contact Öhlins.

👁 Note!

Before working on the product make sure that the vehicle is washed and cleaned properly. Do not use alcobased products on the outside or inside of the product.

Product Specific Warnings

⚠ Warning!

This product was developed and designed exclusively for a specific vehicle model and shall only be installed on the intended vehicle model in its original condition as delivered from the vehicle manufacturer.

⚠ Warning!

This product is pressurized. Do not open, service or modify this product without proper education (authorized Öhlins dealer/distributor) and proper tools.

⚠ Warning!

Always compress the fork fully after mounting crown to ensure proper wheel clearance.

👋 Caution!

Do not use a pressure washer or a power washer when cleaning the fork.

SAFETY SYMBOLS

In this manual, mounting instructions and other technical documents, important information concerning safety is distinguished by the following symbols:



The Safety Alert Symbol means: Warning! Your safety is involved.

⚠ Warning!

The Warning Symbol means: Failure to follow warning instructions can result in severe or fatal injury to anyone working with, inspecting or using the shock absorber/front fork, or to bystanders.

👋 Caution!

The Caution Symbol means: Special precautions must be taken to avoid damage to the shock absorber.

👁 Note!

The Note Symbol indicates information that is important regarding procedures.

© Öhlins Racing AB. All rights reserved.

Any reprinting or unauthorized use without the written permission of Öhlins Racing AB is prohibited.

Oil, grease, thread locker and sealant

Fork lubrication fluid	01336-01 - Renep CGLP 68 Fork lube 1L
Functional grease	01338-22 - Renolit SI 410 M Silicone grease 225g

DH38 Race Fork 50-Hour Service

We recommend using a bike stand to clamp the steering tube when working on the fork.

1. Thoroughly clean the outside of the fork from dirt or grit.
2. Remove the golden bash caps by unscrewing them by hand.
3. Measure and record LSC, HSC and Rebound clicks.
4. Use a 14 mm wrench to hold the rebound adjuster knob steady. With a 2 mm hex wrench remove the screw and the knob.
5. Remove the nut on both sides by using a socket wrench with a 14 mm deep hex socket.

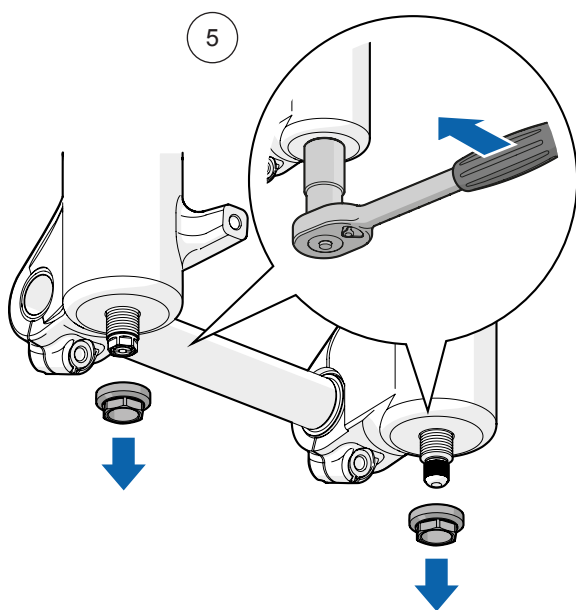
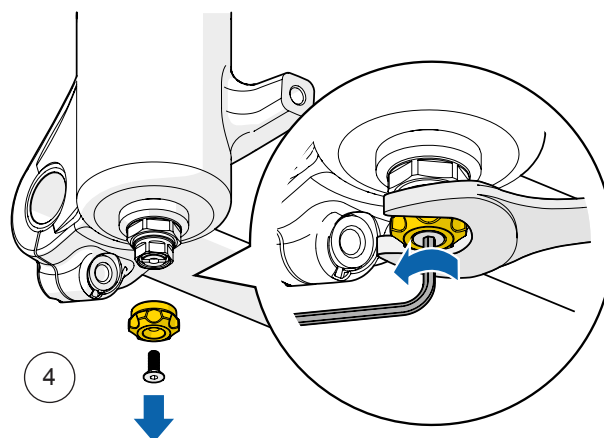
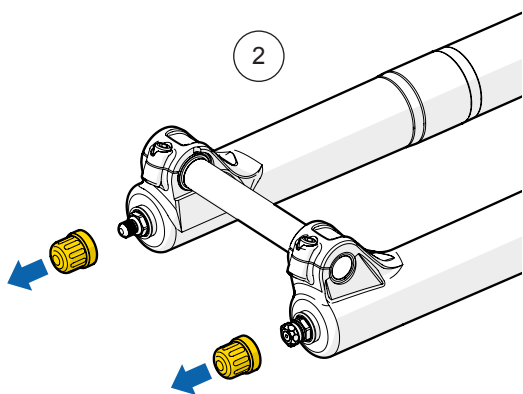
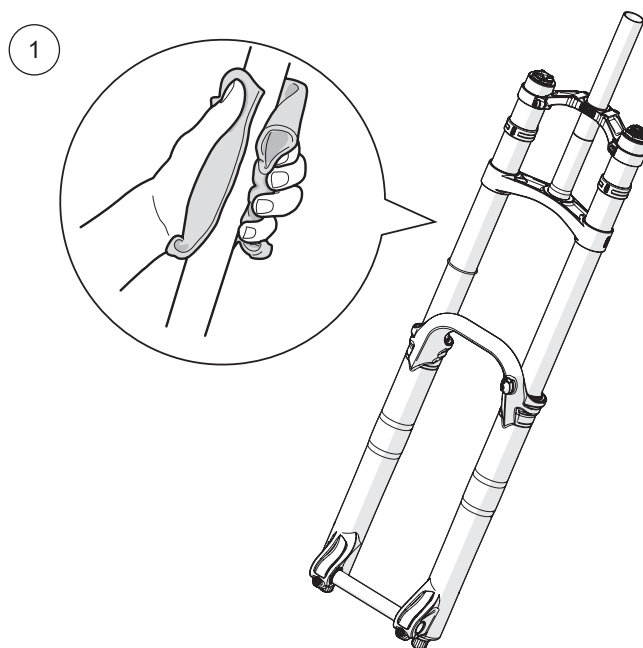

6. Slide the lower legs off the stanchions.

7. Drain the lower legs of all fluids.

8. Use tweezers to cautiously remove the foam rings in the lower legs.

9. Carefully clean the foam rings using disc brake cleaner and a paper cloth or rag to remove old suspension fluid and dirt. Inspect for damages and replace if necessary.

10. Soak the foam rings in fresh fork lubrication fluid.

11. Hold the lower legs upside down and clean the wiper seals and the upper bushings with a soft rag.

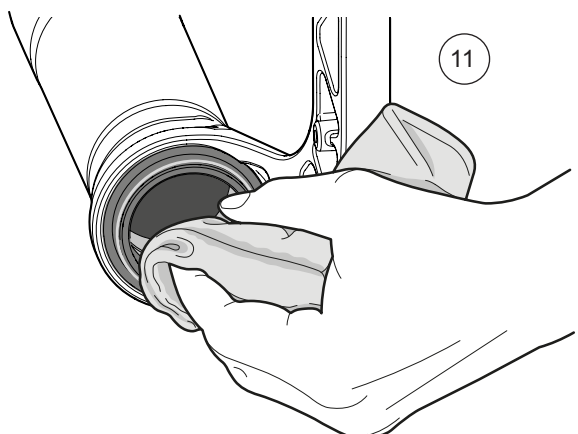
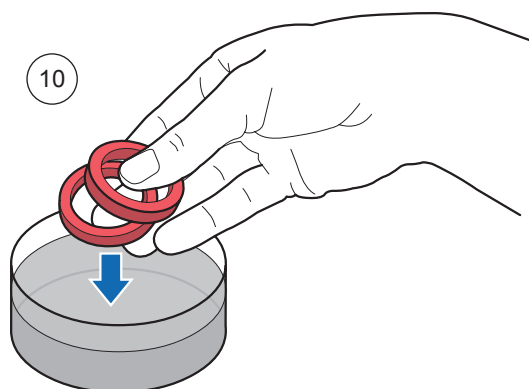
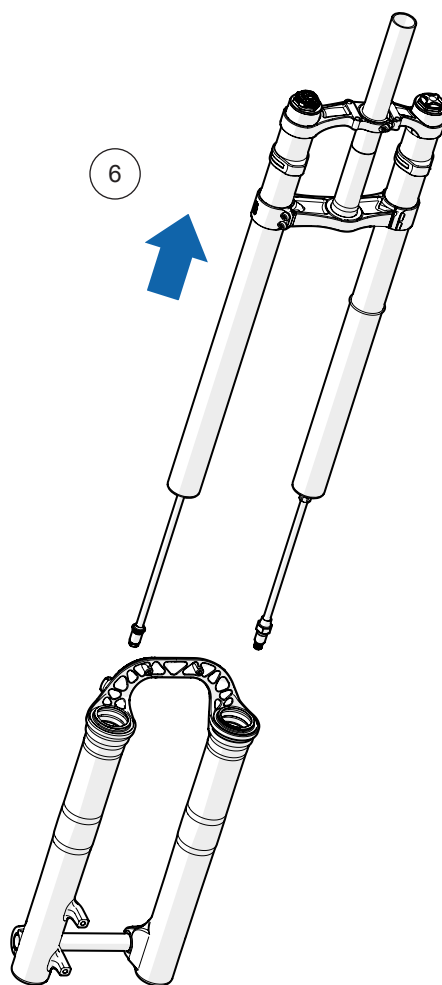
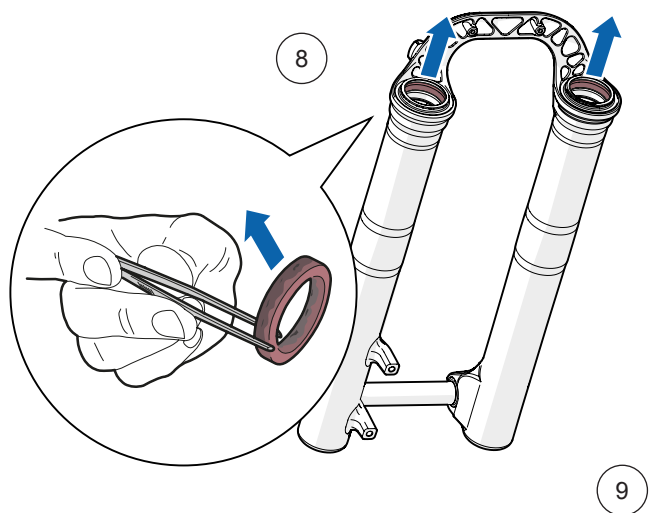

12. Use a rag wrapped around a long rod or similar to clean the insides of the lower legs.

Note!

Be careful not to scratch the bushings.

13. Apply a thin layer of functional grease to the inner surfaces of the wiper seals.

14. Use tweezers to carefully re-insert the soaked foam rings into the lower legs. Check that they are mounted correctly and not twisted.

15. Clean the stanchion tubes with a paper cloth or soft rag.

16. Reinstall the spring stanchion tube into the right side of the lowers.

17. Reinstall the damper stanchion tube into the left side of the lowers.

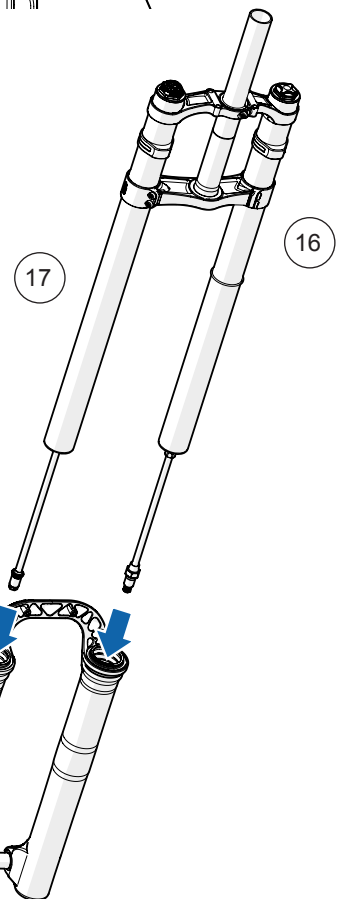
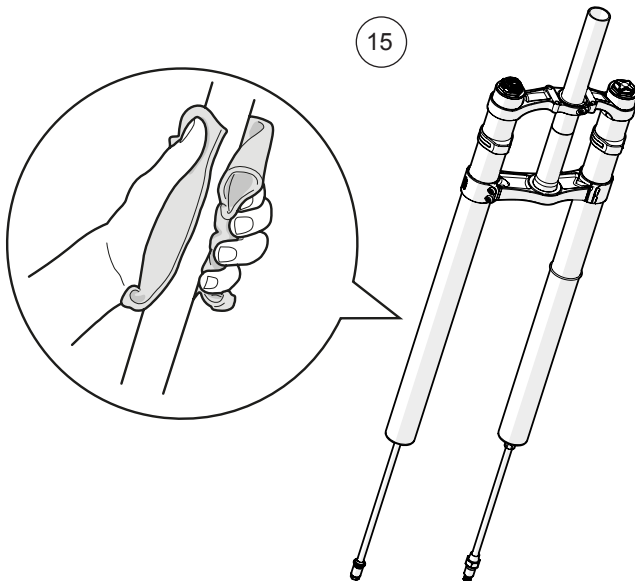
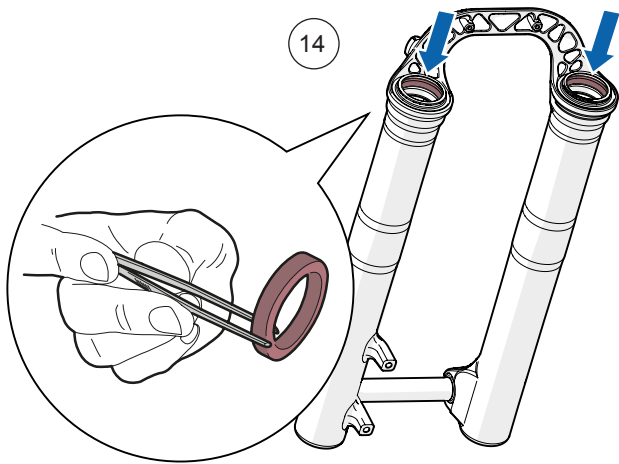
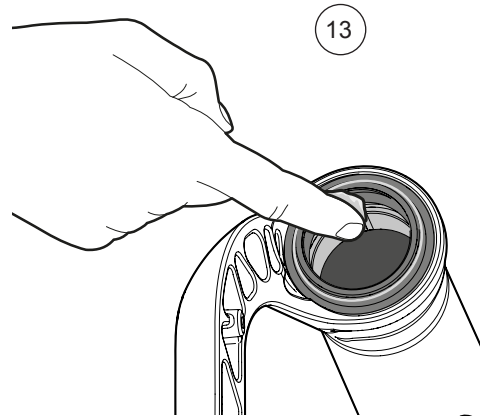
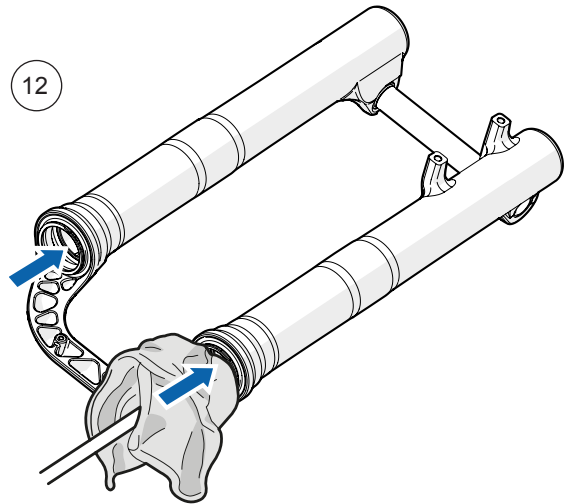

18. Inject 10 ml of fork lubrication fluid into the damper side fork leg and 10 ml into the spring side fork leg.

19. Reinstall the nuts. Use a torque wrench with a 14 mm hex socket and tighten to 10 Nm.

20. Reinstall the rebound adjuster knob and screw. Use a 14 mm wrench to hold the knob steady. With a 2 mm hex wrench tighten the screw and knob.

21. Adjust the rebound setting according to values recorded at step 3.

22. Adjust the LSC and HSC setting according to values recorded at step 3.

23. Reinstall the golden bash caps. Tighten by hand.

23. Install the fork on the bike according to instructions in the Owner's manual.

⚠ Warning!

If the bottom crown is mounted too low the crown will make contact with the tire when bottoming. Always remove air spring pressure and compress the fork fully after mounting to ensure proper tire clearance. Please consult the Owner's manual for further details.

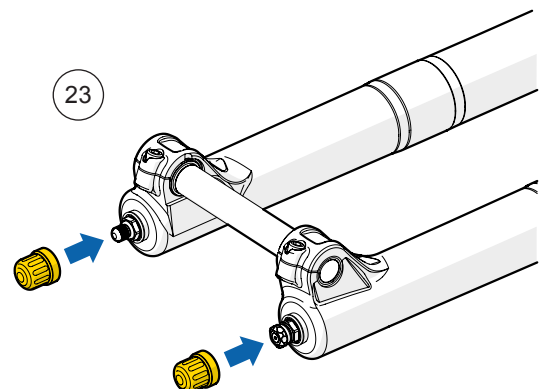
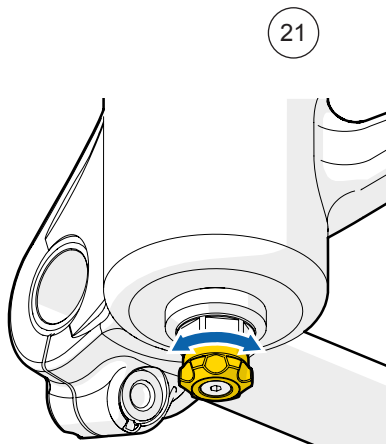
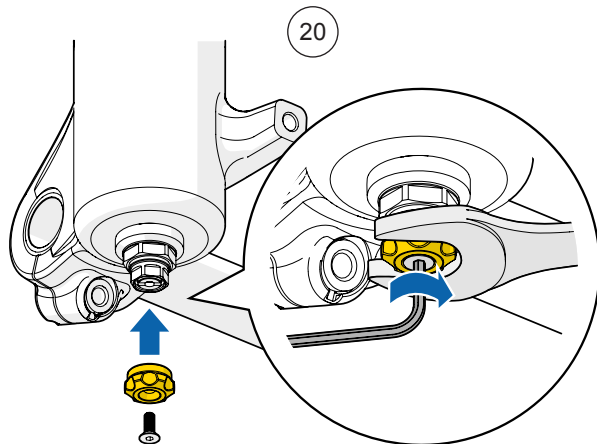
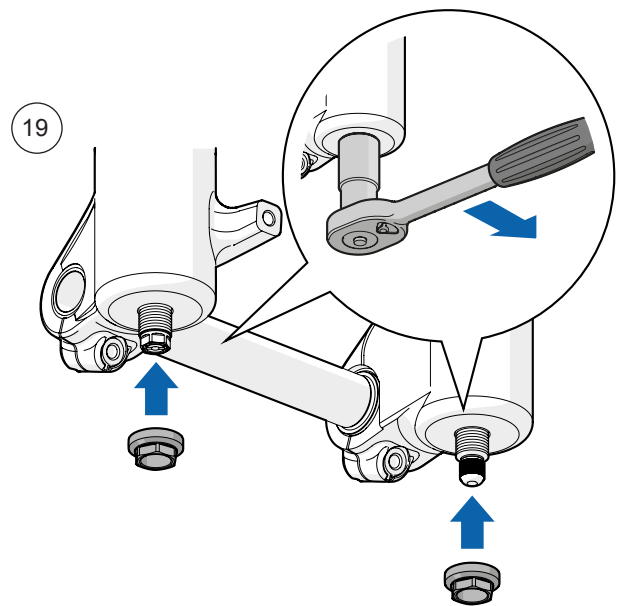
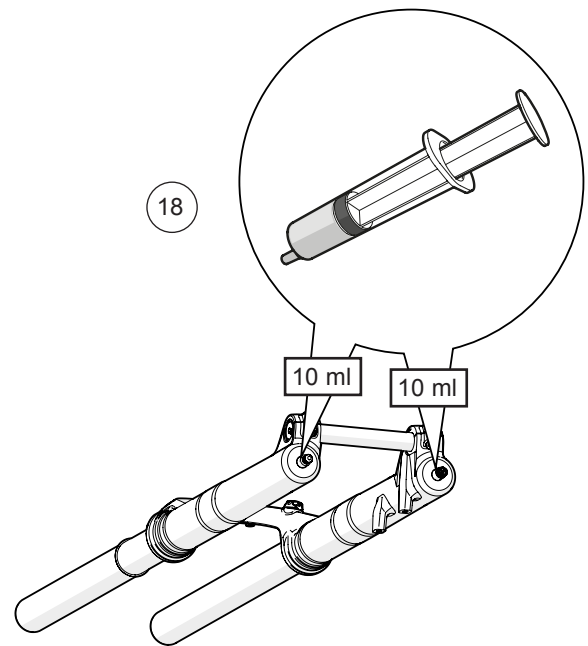

Your Öhlins retailer:

Öhlins Racing AB
Box 722
SE-194 27, Upplands Väsby
Sweden

Phone: +46 (0)8 590 025 00
Fax: +46 (0)8 590 025 80
www.ohlins.com



www.ohlins.com