

Front Fork

RXF34/RXF36/RXF36 m.2

Workshop Manual - Change length Air Spring cartridge



SAFETY PRECAUTIONS

General Warnings

Note!

When working with the Öhlins product, always read the Vehicle Service Manual.

Note!

The shock absorber/front fork/steering damper is an important part of the vehicle and will affect the stability.

Note!

Read and ensure you understand the information in this manual and other technical documents provided by Öhlins, before using the product.

Note!

Öhlins Racing AB can not be held responsible for any damage to the shock absorber/front fork/steering damper, vehicle, other property or injury to persons, if the instructions for mounting, usage and maintenance are not followed exactly.

Warning!

After installing the Öhlins product, take a test ride at low speed to ensure your vehicle has maintained stability.

Warning!

If the suspension makes an abnormal noise, or the function is irregular, or if you notice any leakage from the product, stop the vehicle immediately and return the product to an Öhlins Service Centre.

Warning!

The product warranty shall only apply if the product has been operated and maintained in accordance with recommendations in this manual. If you have any questions regarding usage, service, inspection and/or maintenance please contact Öhlins.

Note!

Before working on the product make sure that the vehicle is washed and cleaned properly. Do not use alcobased products on the outside or inside of the product.

Product Specific Warnings

Warning!

This product was developed and designed exclusively for a specific vehicle model and shall only be installed on the intended vehicle model in its original condition as delivered from the vehicle manufacturer.

Warning!

This product is pressurized. Do not open, service or modify this product without proper education (authorized Öhlins dealer/distributor) and proper tools.

Caution!

Do not use a pressure washer or a power washer when cleaning the fork.

SAFETY SYMBOLS

In this manual, mounting instructions and other technical documents, important information concerning safety is distinguished by the following symbols:



The Safety Alert Symbol means: Warning! Your safety is involved.

Warning!

The Warning Symbol means: Failure to follow warning instructions can result in severe or fatal injury to anyone working with, inspecting or using the shock absorber/front fork, or to bystanders.

Caution!

The Caution Symbol means: Special precautions must be taken to avoid damage to the shock absorber.

Note!

The Note Symbol indicates information that is important regarding procedures.

© Öhlins Racing AB. All rights reserved.

Any reprinting or unauthorized use without the written permission of Öhlins Racing AB is prohibited.

TABLE OF CONTENTS

Tools	3
Overview - General layout	3
Kit contents	4
Remove lower legs	5
Change length of air spring cartridge	9
Appendix A	15

RXF34/RXF36/RXF36 M.2

Tools

1	18860-01	Hex socket 28 mm
2	19245-01	Multi clamp TTX18
3	-	Cassette locking tool

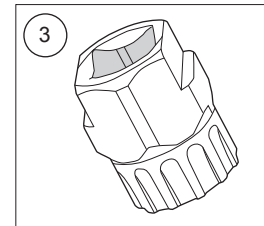
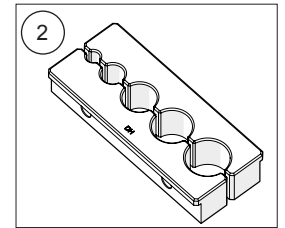
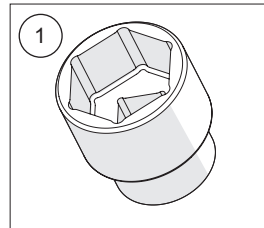

Oil, grease, thread locker and sealant

Fork lubrication fluid	01336-01 - Renep CGLP 68 Fork lube 1L
Air spring lubrication fluid	01337-06 - Renep CGLP 220 Air spring lube 0.6L
Function grease	01338-22 - Renolit SI 410 M Silicone grease 225g
Assembly grease	Slickoleum / Buzzy's Slick Honey
Loctite 243	01791-03

Overview - General layout

- 1 Chassis
- 2 Air Spring Cartridge
- 3 Damper Cartridge

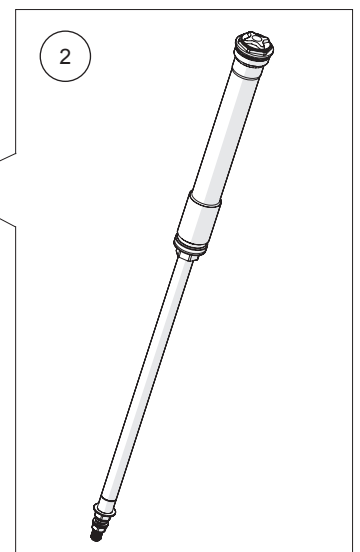
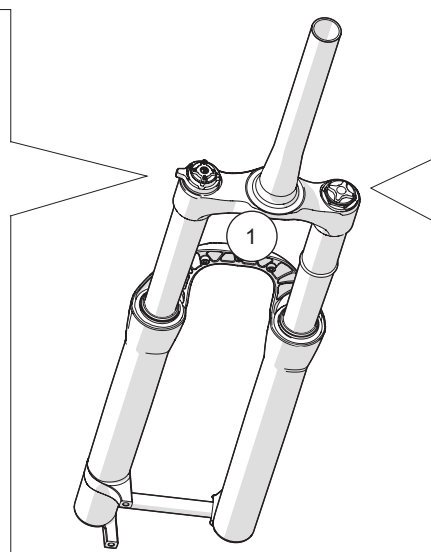
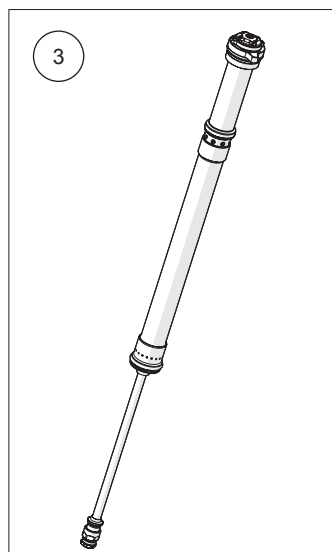

RXF34/RXF36/RXF36 M.2

Kit contents

1	18976-09	Air spring rebuild to 90 mm kit
2	18976-08	Air spring rebuild to 100 mm kit
3	18976-01	Air spring rebuild to 120 mm kit
4	18976-02	Air spring rebuild to 130 mm kit
5	18976-03	Air spring rebuild to 140 mm kit

6	18976-04	Air spring rebuild to 150 mm kit
7	18976-05	Air spring rebuild to 160 mm kit
8	18976-06	Air spring rebuild to 170 mm kit
9	18976-07	Air spring rebuild to 180 mm kit

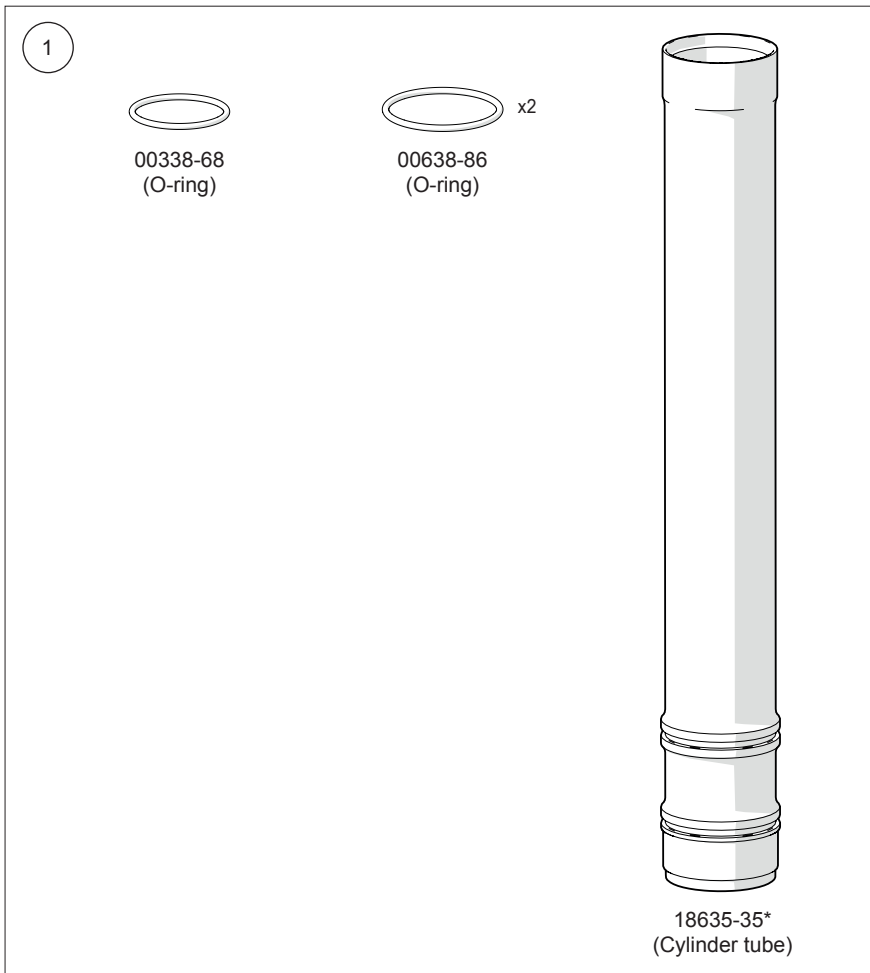

*Content is the same for all kits above except for the cylinder tube that has different lengths.

RXF34/RXF36/RXF36 M.2

Remove air spring from lower legs

👁 Note!

Record the rebound adjuster setting and the pressure in the positive air chamber and ramp up chamber before service. We recommend using a bike stand to clamp the steering tube when working on the fork.

1. Thoroughly clean the outside of the fork from dirt or grit. Place the fork in a bike stand according to picture with air spring side pointing upwards and the fork on the right hand side of the clamp jaws.

2. Release the air from the positive air chamber at the top and the ramp up chamber at the bottom.

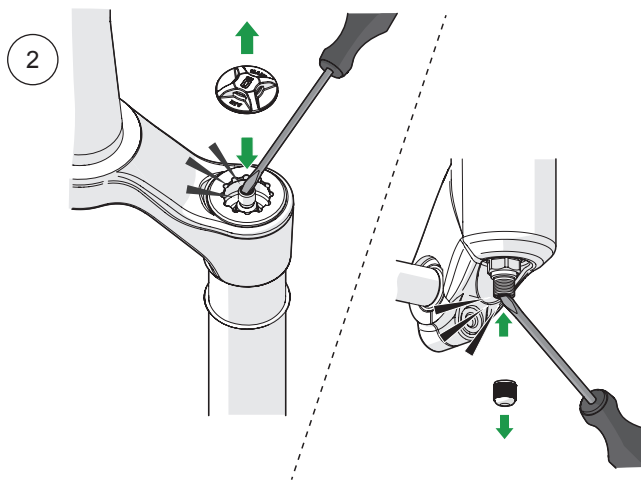
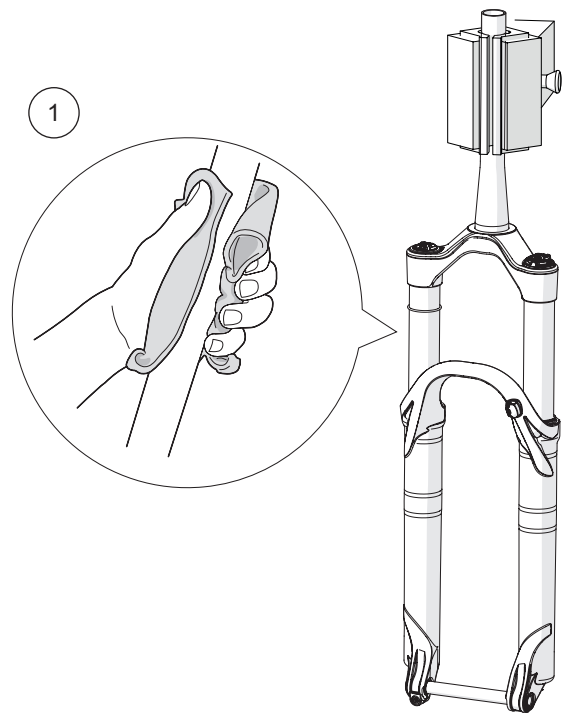

RXF34/RXF36/RXF36 M.2

3. Use a socket wrench with a 12 mm or 14 mm (no washer) deep hex socket to remove the washer and the nut on the lower air valve.

4. Use a socket wrench with a hex socket 28 mm (18860-01) or a cassette locking tool to loosen the air spring.

⚠ Caution!

Do not use an adapter between wrench and socket, as this will increase the risk of damaging the anodized finish of the top cap.

👁 Note!

When removing the Air Spring cartridge, it is easy to damage the Top Cap. Put pressure on the wrench while unthreading the Top Cap.

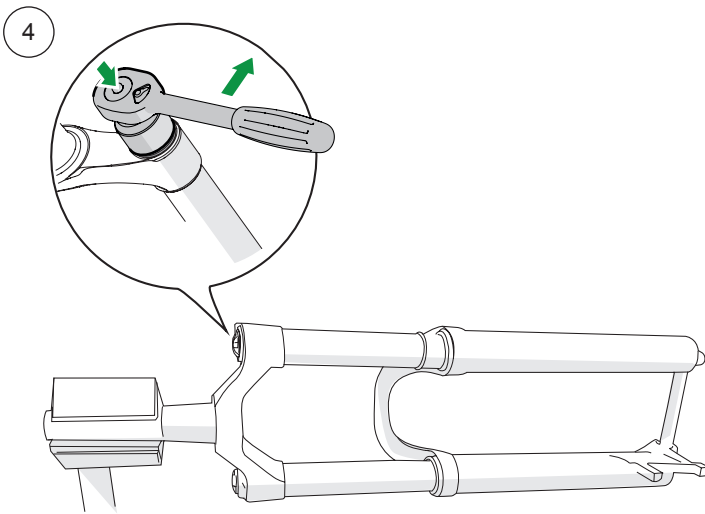
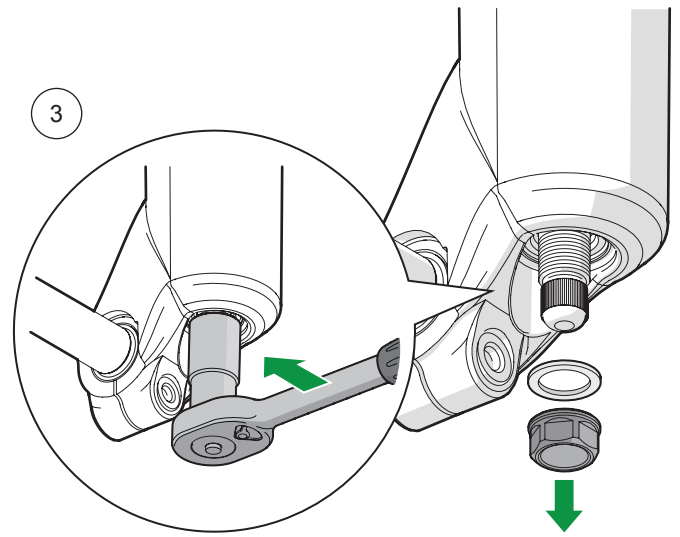

RXF34/RXF36/RXF36 M.2

Change length of air spring cartridge

👁 Note!

Clean all parts using disc brake cleaner and a rag to remove dirt, old grease and thread sealant before reassembling. Lubricate new o-rings/x-rings etc. with fresh Assembly grease.

👁 Note!

Use a vise and the appropriate shaft clamps when servicing the front fork.

1. Slide the air spring off the stanchion tube.

2. Use a 19/24 mm wrench to loosen the seal head. Slide the cylinder tube off the air spring.

3.

If you used a cassette tool to undo the top cap leave the pre-applied thread locker(reusable) and continue. If you used a 28 mm socket clean top cap threads (male and female) using a rag covered by degreaser or brake cleaner. Use a nylon bristled brush to remove any remaining residue from threads.

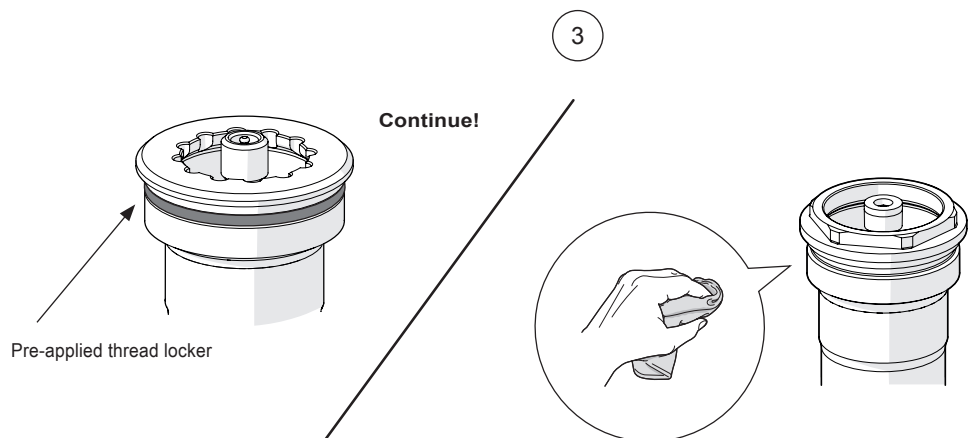
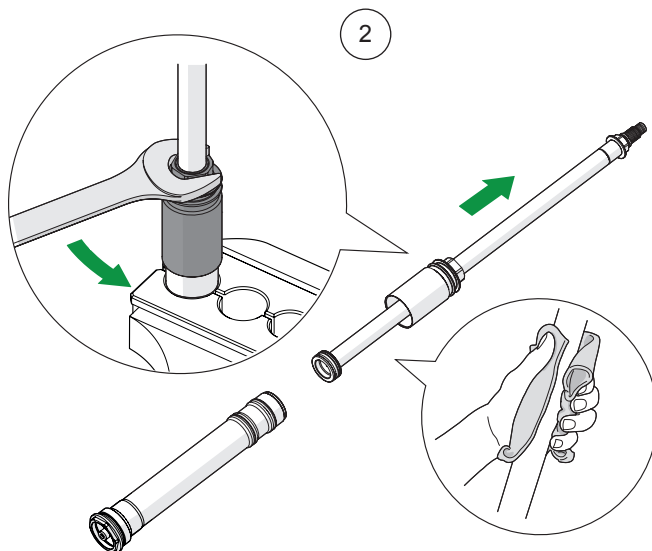
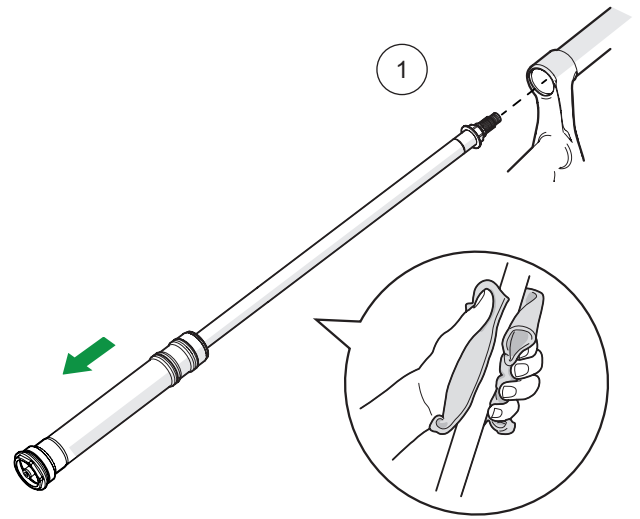

RXF34/RXF36/RXF36 M.2

3. Use a socket wrench with a hex socket 28 mm (18860-01) or a cassette locking tool to remove the top cap.

4. Remove the old o-ring (00338-68) from the top cap. Clean using disc brake cleaner and a paper cloth or rag to remove old thread sealant.

5. Install a new o-ring (00338-68) on the top cap. Apply assembly grease on o-ring.

6. Replace the cylinder tube with the new cylinder tube (shorter/ longer). Note that there is a max allowed stroke depending on fork chassis, see table below.

See Appendix A to determine the part no of the fork.

Part no fork	Max allowed stroke
FGxxx 36xx 211x\212x	170 mm
FGxxx 36xx 216x\217x	180 mm
FGxxx 36xx 201x\202x	170 mm
FGxxx 36xx 206x\207x	180 mm
FG361x 19xx	170 mm
FG361x 1715/1716	170 mm
FG361x 1711/1712/1731	160 mm
FG3612 151x	140 mm
FG3614 151x	140 mm
FG3615 151x	160 mm
FG3616 151x	160 mm
FG361x 152x	160 mm
FG3412 151x	140 mm
FG3414 151x	140 mm
FG3416 151x	160 mm

7. Install two new o-rings (00638-86) on the new upper air chamber cylinder tube. Apply assembly grease on o-rings.

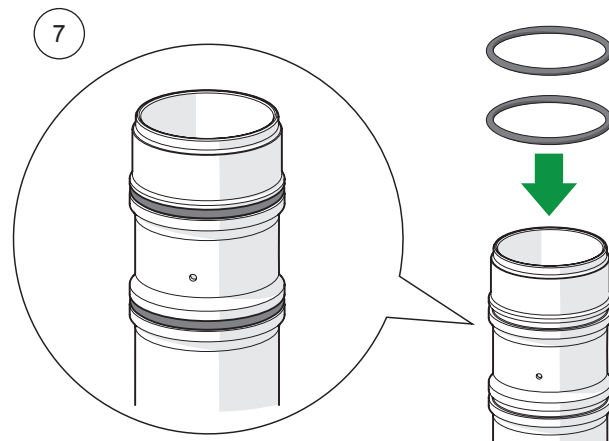
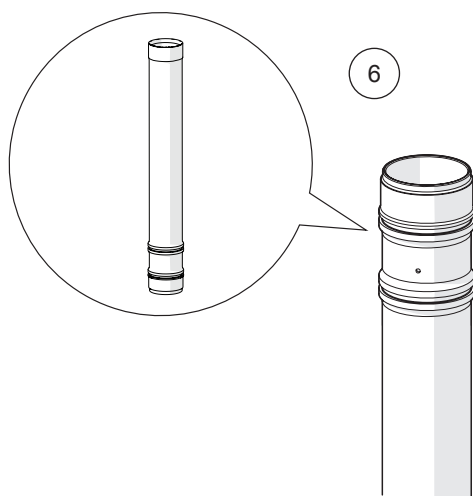
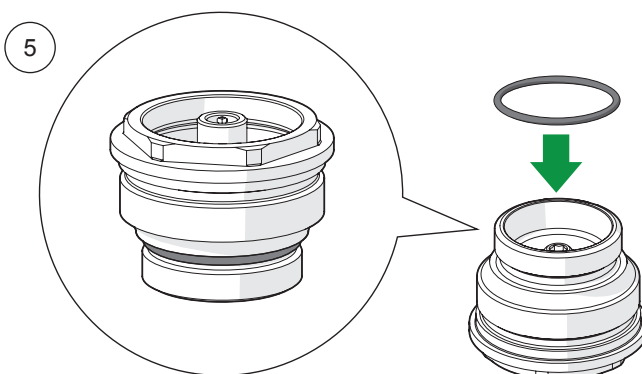
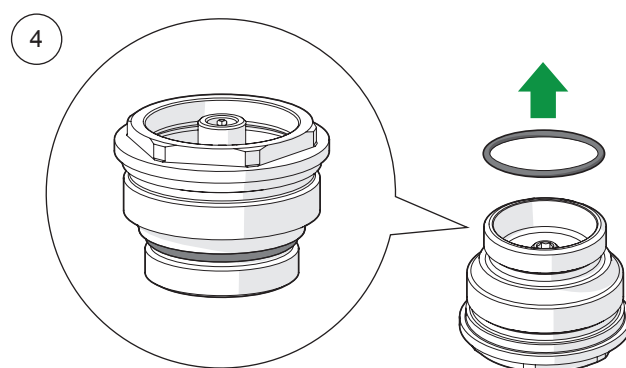
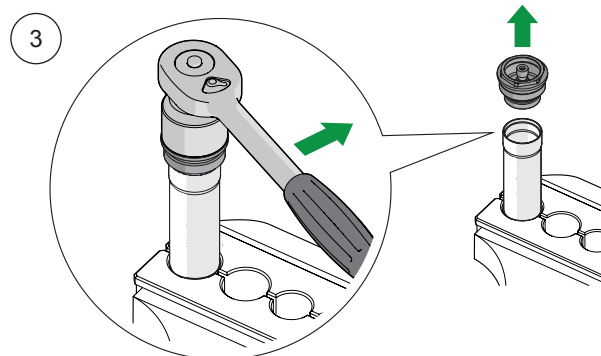

RXF34/RXF36/RXF36 M.2

8. Apply a half turn of Loctite 577 thread sealant (01791-07) to the top cap threads.

9. Thread the top cap into the cylinder tube. Use a torque wrench with a 28 mm hex socket or a cassette locking tool to tighten the top cap to 10 Nm.

10. Release the cylinder tube from the multiclamp, turn it upside down so that the o-rings are pointing upwards and mount it in the multiclamp.

11. Apply 2 ml of function grease at the inside of the cylinder tube (smeared around). Add 0,5 ml of air spring lubrication fluid distributed on top of the grease.

12. Apply a thin layer of function grease on the o-ring and the back-up rings on the main piston.

13. Insert main piston in the cylinder tube and add 0,5 ml of air spring lubrication fluid inside the cylinder tube. Slide the seal head onto the cylinder tube and screw them together hand-tight.

14. Use a 19/24 mm torque wrench to tighten the seal head to 10 Nm.

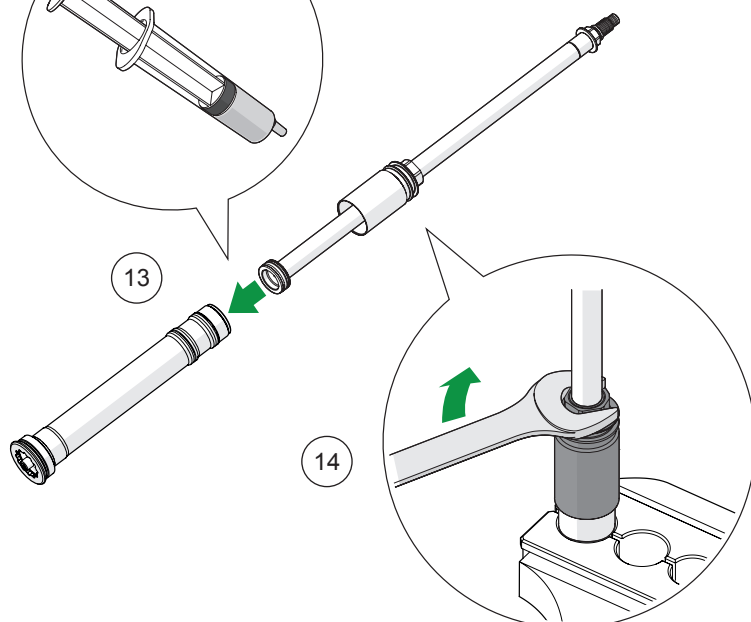
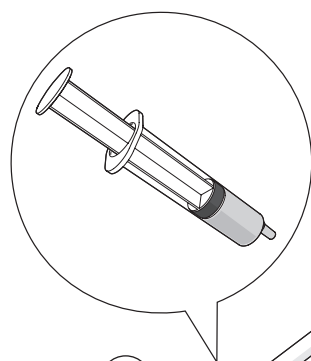
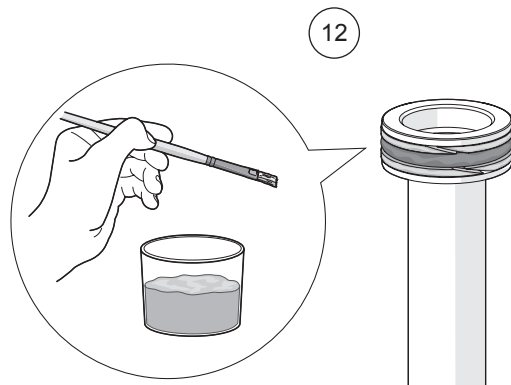
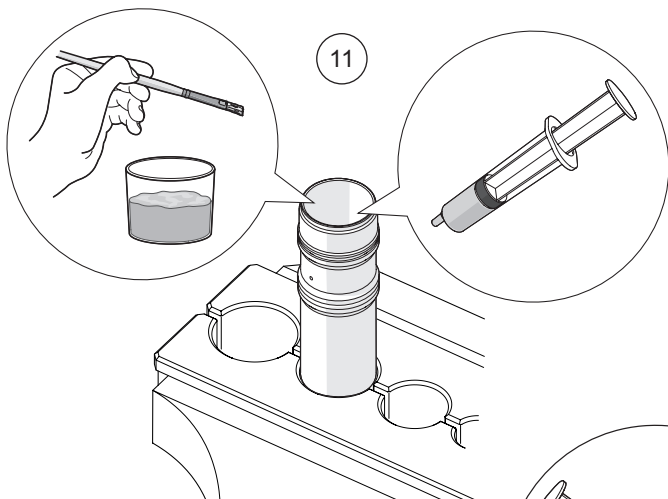
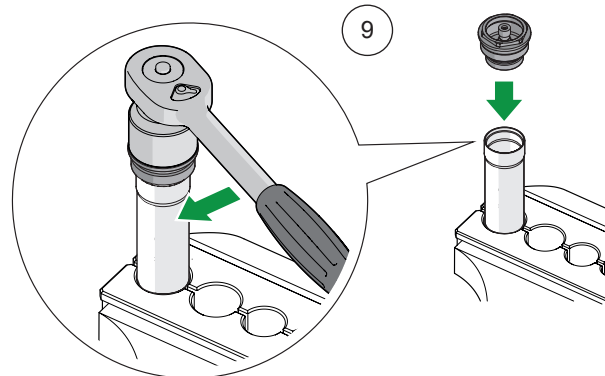
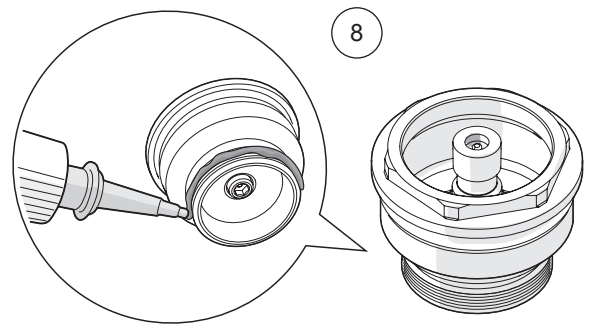

RXF34/RXF36/RXF36 M.2

15. Reinstall the Air spring cartridge into the stanchion tube.

Note!

If the 28 mm hex socket was used in previous steps perform step 16 applying loctite.

16. Apply blue Loctite 243 to the first (lower) two (2) threads of the top cap (male).

17. Use a torque wrench with a 28 mm hex socket (18860-01) or a cassette locking tool to tighten the top cap to 32 Nm.

Caution!

Do not use an adapter between wrench and socket, as this will increase the risk of damaging the anodized finish of the top cap.

18. Wipe off eventual excessive Loctite 243.

Important!

Leave the Loctite to cure for 24 hours before riding.

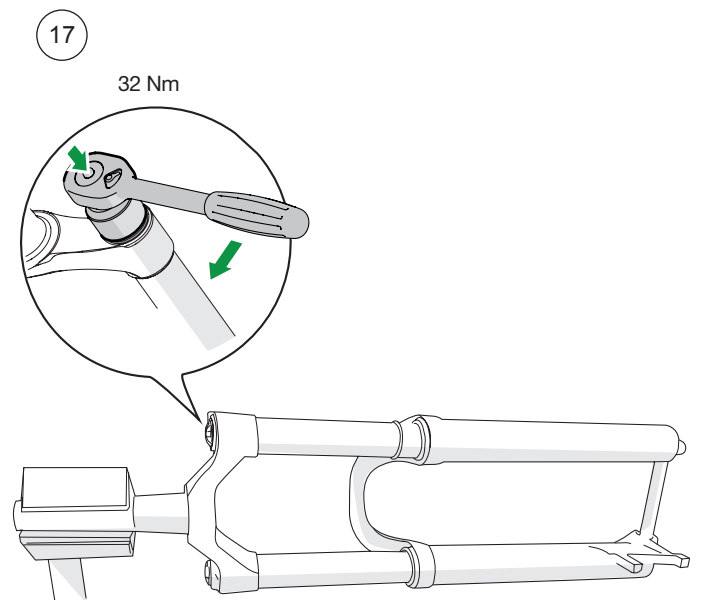
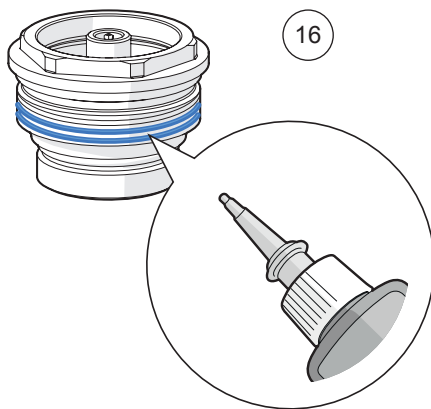
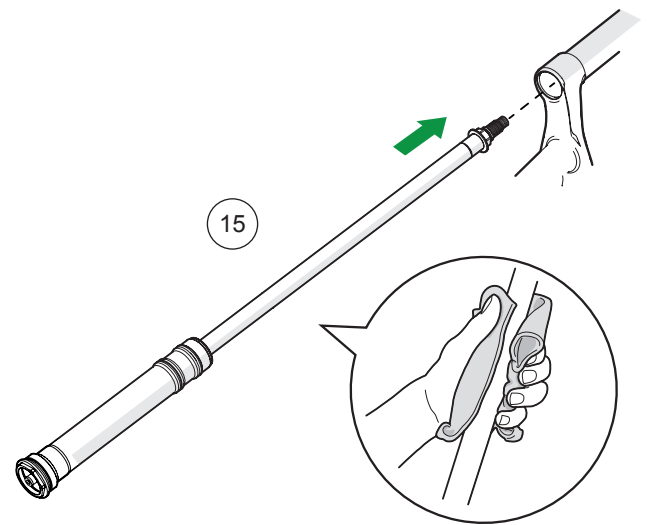

RXF34/RXF36/RXF36 M.2

19. Refit the lower valve nut and washer if the was one mounted.
Tightening torque 10 Nm.

20. Inflate the ramp up chamber (A) at the bottom and then the positive air chamber (B) at the top to the desired air pressures.

⚠ Caution!

Inflate the ramp up chamber (A) at the bottom first.

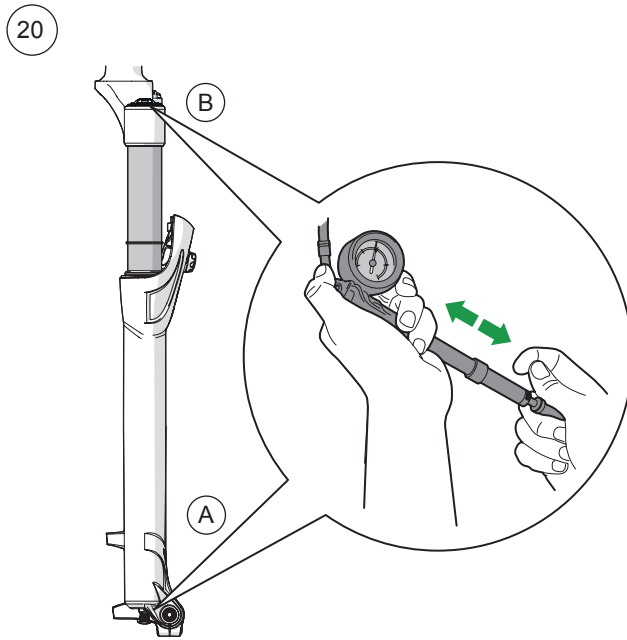
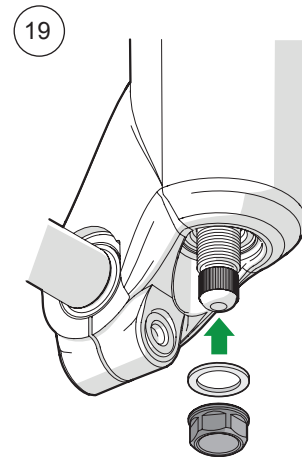

RXF34/RXF36/RXF36 M.2

Appendix A

Part no of the fork can be found at the bottom of the steering tube.

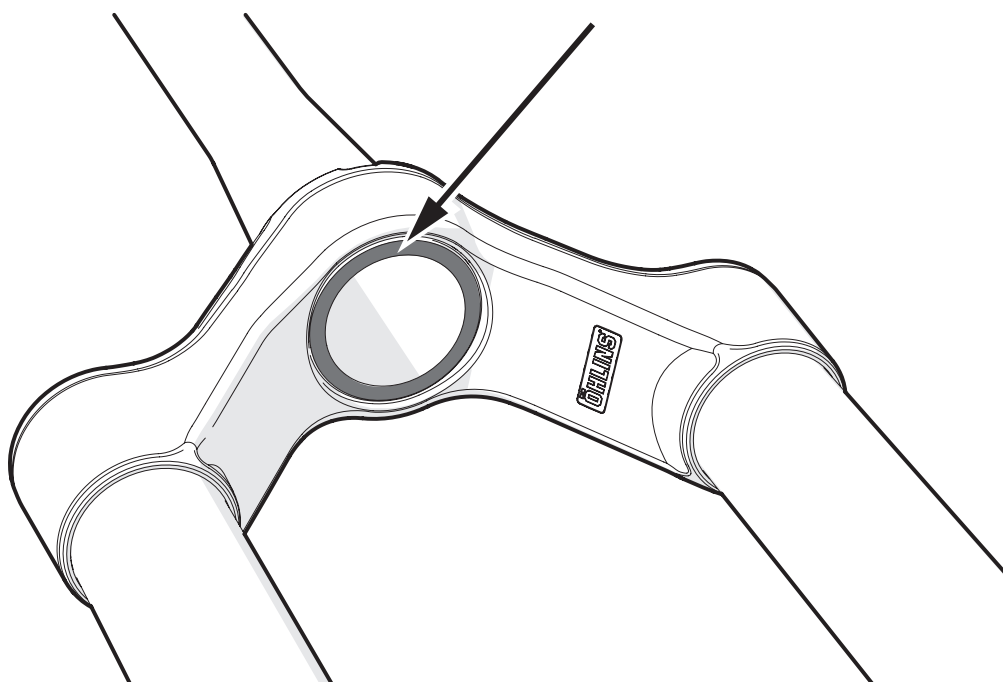

Your Öhlins retailer:

Öhlins Racing AB
Box 722
SE-194 27, Upplands Väsby
Sweden

Phone: +46 (0)8 590 025 00
Fax: +46 (0)8 590 025 80
www.ohlins.com



www.ohlins.com