

Shock Absorber for Formula Student and Formula SAE

TTX 25

Workshop Manual



General Warnings

Note!

The shock absorber is an important part of the vehicle and will affect the stability.

Note!

Read and ensure you understand the information in this manual and other technical documents provided by Öhlins, before using the product.

Note!

Öhlins Racing AB can not be held responsible for any damage to the shock absorber, vehicle, other property or injury to persons, if the instructions for mounting, usage and maintenance are not followed exactly.

Warning!

After installing the Öhlins product, take a test ride at low speed to ensure your vehicle has maintained stability.

Warning!

If the suspension makes an abnormal noise, or the function is irregular, or if you notice any leakage from the product, stop the vehicle immediately and return the product to an Öhlins Service Centre.

Warning!

The product warranty shall only apply if the product has been operated and maintained in accordance with recommendations in this manual. If you have any questions regarding usage, service, inspection and/or maintenance please contact Öhlins.

Note!

When working with the Öhlins product, always read the Vehicle Service Manual.

Warning!

This product contains pressurized nitrogen gas (N₂). Do not open, service or modify this product without proper education (authorized Öhlins dealer/distributor) and proper tools.

Safety Symbols

In this manual, mounting instructions and other technical documents, important information concerning safety is distinguished by the following symbols:



The Safety Alert Symbol means: Warning! Your safety is involved.

Warning!

The Warning Symbol means: Failure to follow warning instructions can result in severe or fatal injury to anyone working with, inspecting or using the shock absorber, or to bystanders.



Caution!

The Caution Symbol means: Special precautions must be taken to avoid damage to the shock absorber.

Note!

The Note Symbol indicates information that is important regarding procedures.

	Page
SAFETY PRECAUTIONS.....	2
TOOLS	4
1 - PRESSURE.....	5
1.1 Depressurize	5
1.2 Pressurize	7
2 - REMOVE SHAFT ASSEMBLY	8
3 - REPLACE END-EYE.....	9
3.1 Disassemble.....	9
3.2 Assemble.....	10
4 - REPLACE SEAL HEAD	11
4.1 Disassemble.....	11
4.2 Assemble.....	11
5 - REPLACE PISTON BAND	12
5.1 Disassemble.....	12
5.2 Assemble.....	12
6 - REPLACE SEPARATING PISTON SEAL	13
6.1 Disassemble.....	13
6.2 Assemble.....	14
7 - CHANGE VALVE SPECIFICATION.....	15
7.1 Disassemble.....	15
7.2 Assemble.....	17
8 -OIL FILL PROCEDURE.....	18

TOOLS

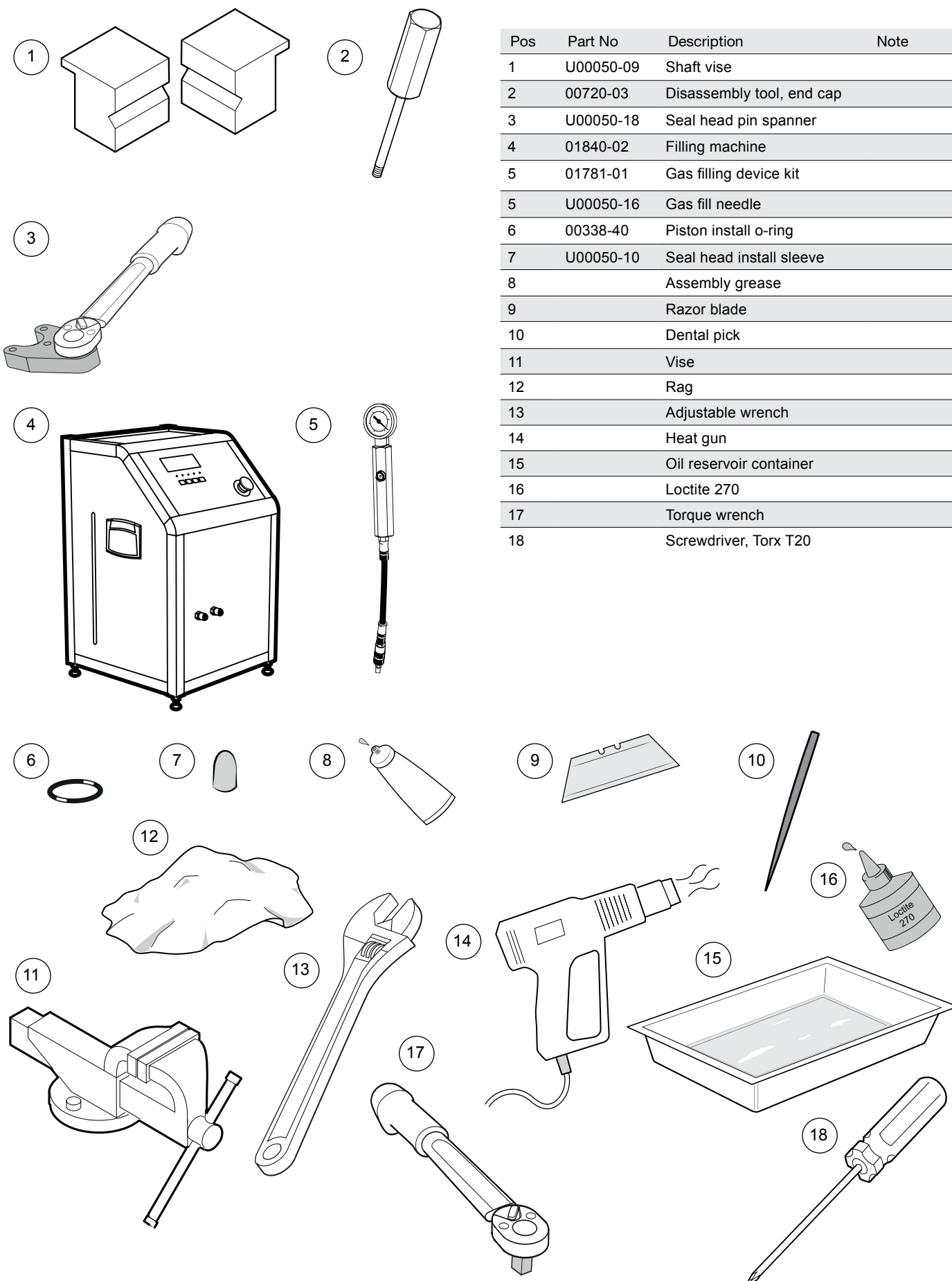

Pos	Part No	Description	Note
1	U00050-09	Shaft vise	
2	00720-03	Disassembly tool, end cap	
3	U00050-18	Seal head pin spanner	
4	01840-02	Filling machine	
5	01781-01	Gas filling device kit	
5	U00050-16	Gas fill needle	
6	00338-40	Piston install o-ring	
7	U00050-10	Seal head install sleeve	
8		Assembly grease	
9		Razor blade	
10		Dental pick	
11		Vise	
12		Rag	
13		Adjustable wrench	
14		Heat gun	
15		Oil reservoir container	
16		Loctite 270	
17		Torque wrench	
18		Screwdriver, Torx T20	

1.1 Depressurize

1.1.1

Note the adjuster settings.

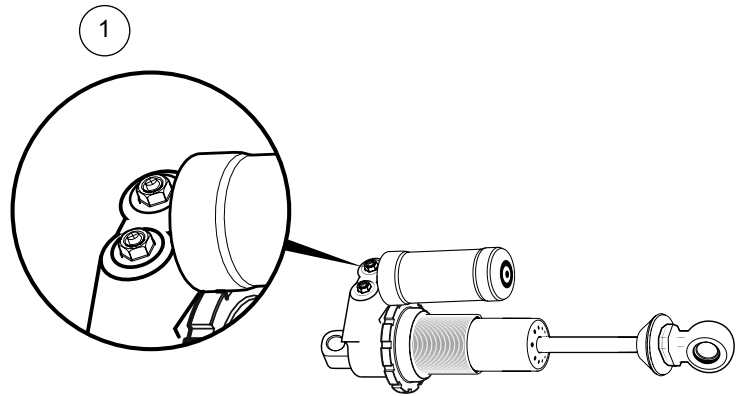

1.1.2

Put the damper in a vise with the cylinder tube axis pointing vertically.

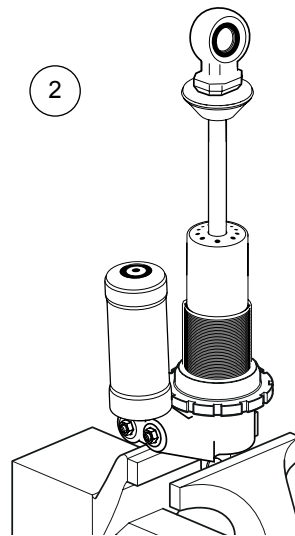

1.1.3

Remove the screw and o-ring at the bottom of the external reservoir. Use a Torx T20 screwdriver.

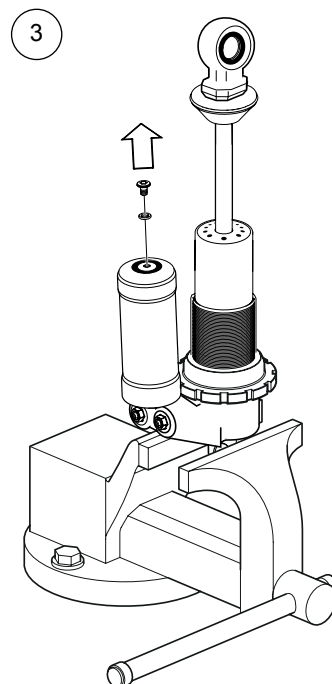

1 - PRESSURE

⚠ Warning!

For safety reasons, use Gas fill needle (U00050-16)/ Gas filling device kit (01781-01) with special care. Read the instructions provided with the tool.

⚠ Warning!

Be careful when working with a Needle.

1.1.4

Insert the Gas fill needle (U00050-16). Note the gas pressure. Ideal pressure is 5 Bar.

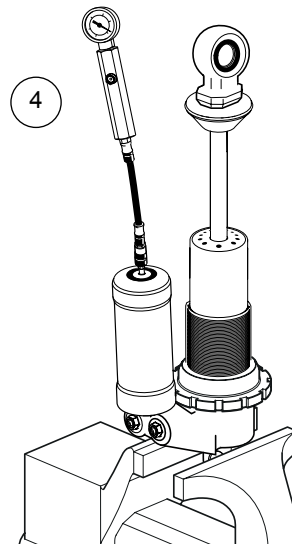

1.1.5

Open the Gas fill needle valve to bleed pressure from reservoir. Remove Gas fill needle.

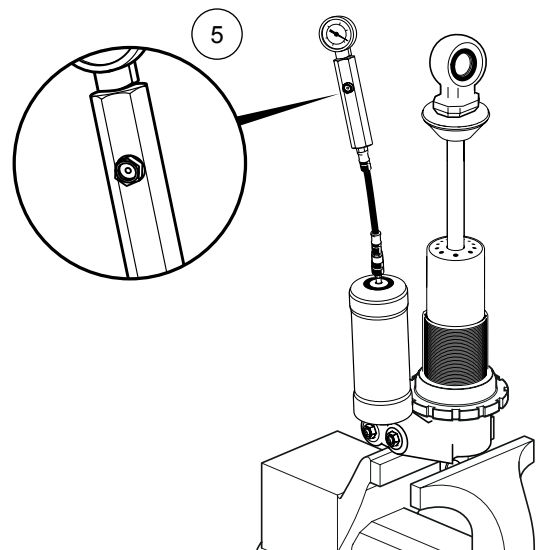

1.2 Pressurize

⚠ Warning

Only use nitrogen gas (N_2) to pressurize the shock absorber. Nitrogen is an inflammable gas that does not affect the materials in the gas reservoir.

1.2.1

After your work is complete, insert the Gas fill needle assembly and pressurize to 5 Bar.

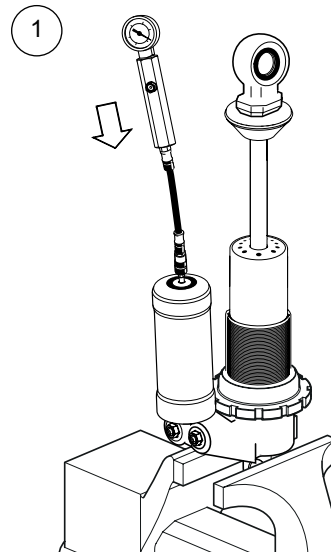

1.2.2

Remove the Gas fill needle and install the screw and o-ring.

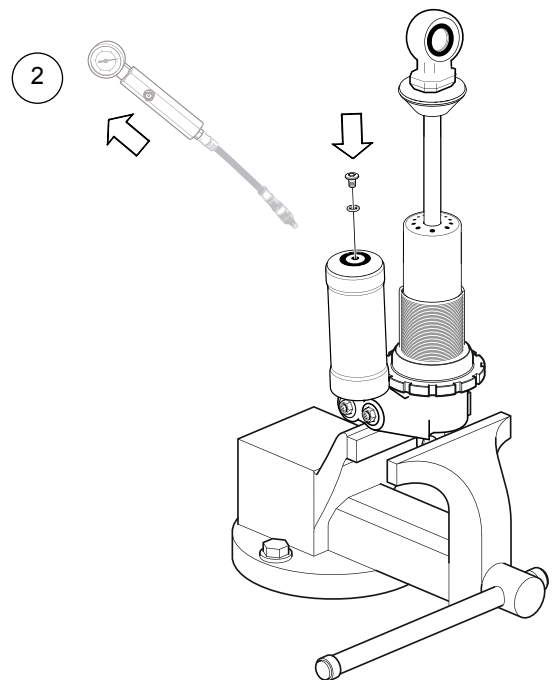

2 - REMOVE SHAFT ASSEMBLY

2. Remove Shaft Assembly

2.1

Release gas pressure. See chapter 1 - Pressure.

2.2

Unscrew the seal head using the Seal head pin spanner (U00050-18).

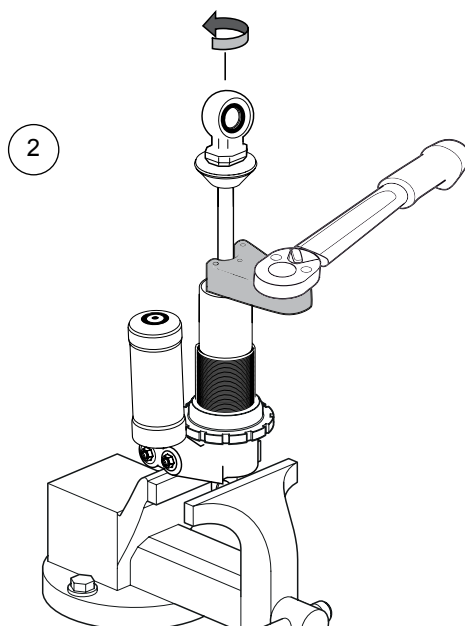

2

2.3

Carefully remove the shaft assembly from the cylinder tube.

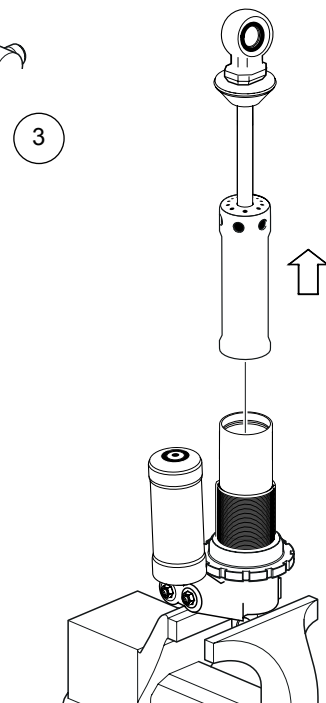

3

2.4

Drain the fluid from the damper.

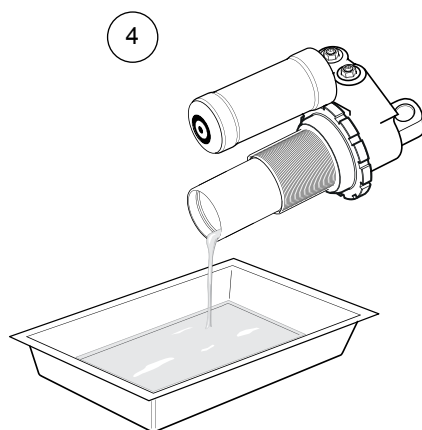

4

3 - REPLACE END-EYE

3.1 Disassemble

3.1.1

Clean the shaft of dirt and damper fluid. Clamp the shaft using the Shaft vise (U00050-09).

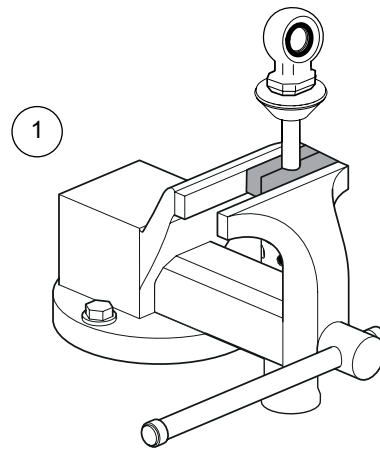

3.1.2

Use a heat gun to loosen the Loctite from the shaft/end eye threads.

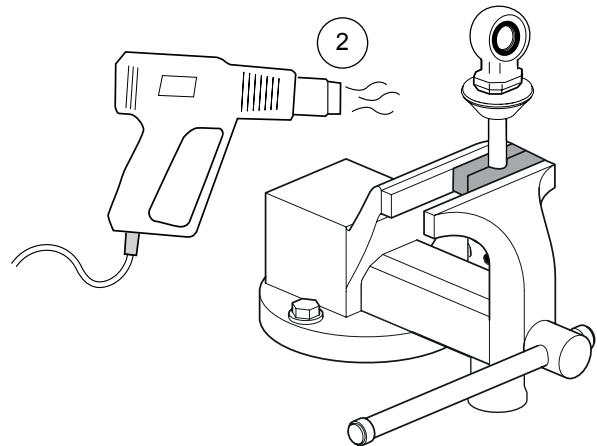

3.1.3

Use a 13 mm (or 1/2") open end wrench or an adjustable wrench on the flats of the end eye and unscrew.

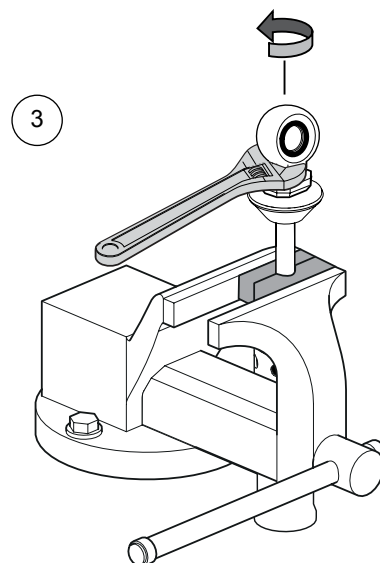

3 - REPLACE END-EYE

3.2 Assemble

3.2.1

Clean the Loctite from the threads on the shaft and end eye. (Tip: If performing a rebuild wait to install the end eye until after the damper has been filled with damper fluid).

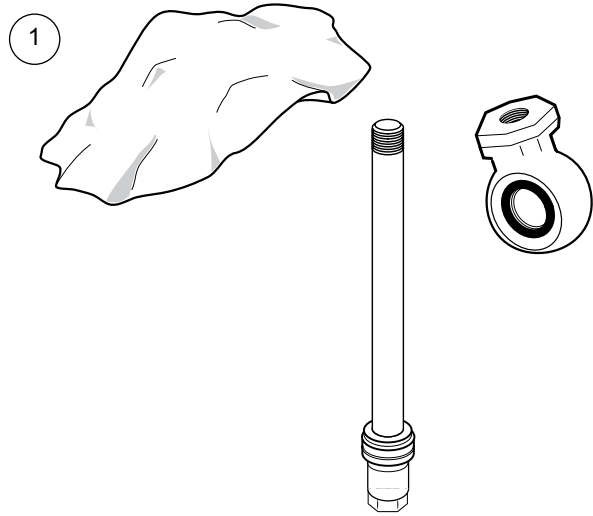

3.2.2

Apply one small drop of Loctite 270 to the threads of the shaft.

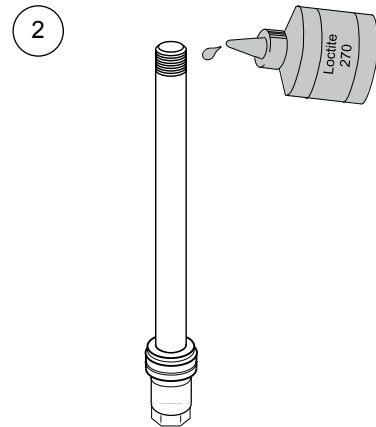

3.2.3

Install end eye to 10 Nm.

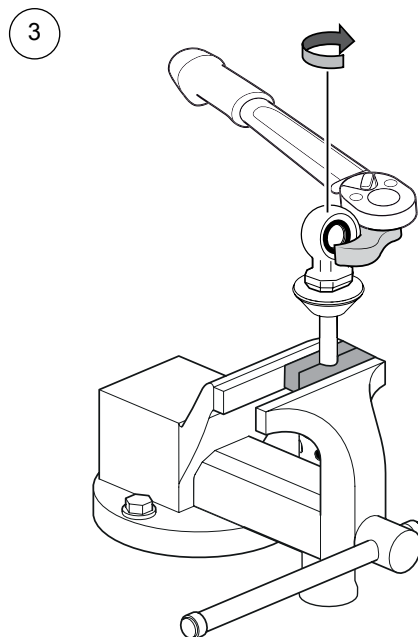

4 - REPLACE SEAL HEAD

4.1 Disassemble

4.1.1

Remove shaft assembly, see chapter 2.

4.1.2

Remove end-eye, see chapter 3.

4.1.3

Carefully remove the seal head from the shaft.

Note!

If you are re-using the seal head it is recommended that you replace the shaft seal.

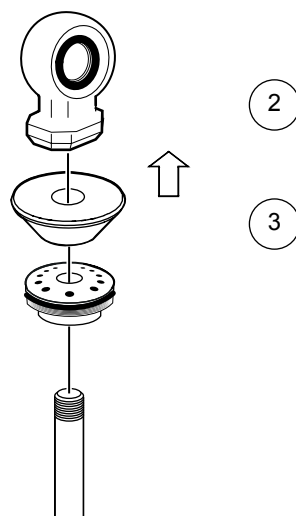

4.2 Assemble

4.2.1

Install the Seal head install sleeve (U00050-10) on to the threads of the shaft and apply some grease.

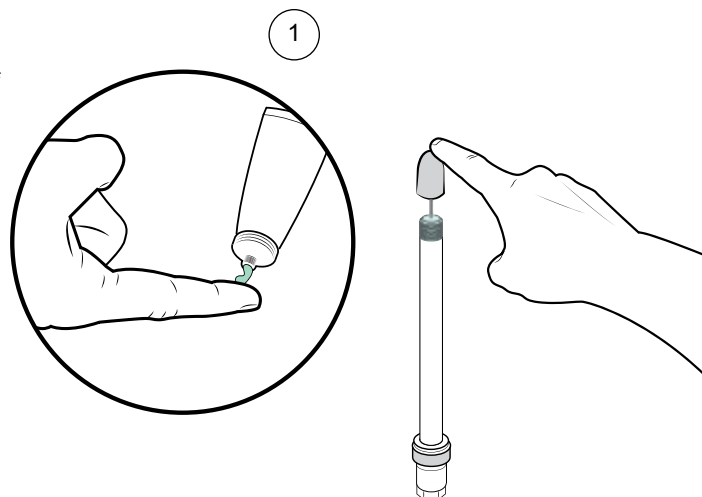

4.2.2

Carefully slide the seal head on to the shaft. (Tip: If performing a rebuild wait to install seal head on the shaft until the piston and shaft assembly have been installed into the inner tube).

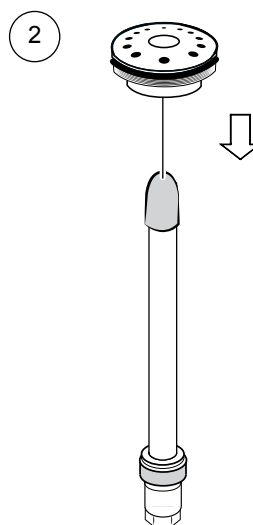

4.2.3

Insert the piston and shaft assembly, see chapter 8.

5 - REPLACE PISTON BAND

5.1 Disassemble

5.1.1

Remove shaft assembly, see chapter 2.

5.1.2

Remove the old piston band and o-ring.

Note!

Always be careful not to scratch the o-ring groove when replacing the o-ring.

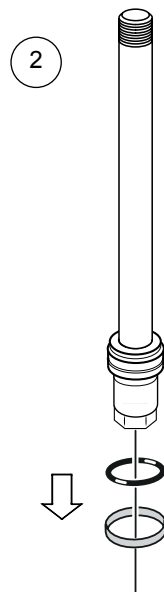

5.2 Assemble

5.2.1

Apply grease to the new o-ring and piston band and install.

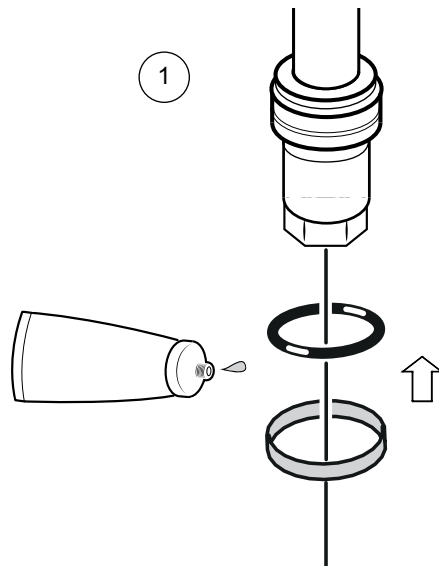

5.2.2

Wrap the piston band with the Piston install o-ring (00338-40).

5.2.3

Install shaft assembly into the damper. See chapter 8 - Oil Fill Procedure.

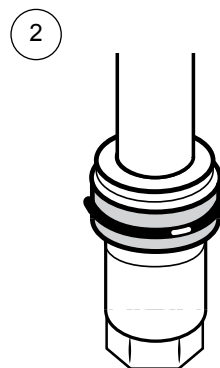

6 - REPLACE SEPARATING PISTON SEAL

6.1 Disassemble

6.1.1

Use Disassembly tool, end cap (00720-03) to press down on the reservoir end cap.

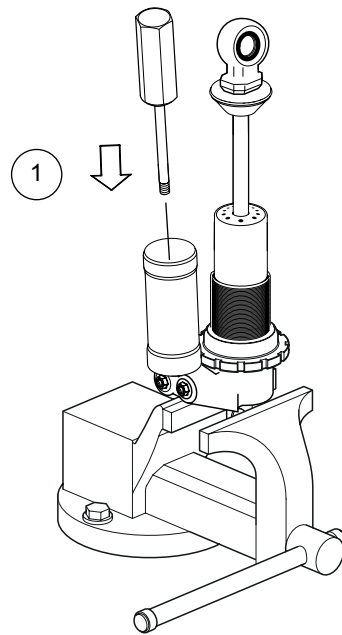

6.1.2

Remove the circlip and pull the reservoir end cap out.

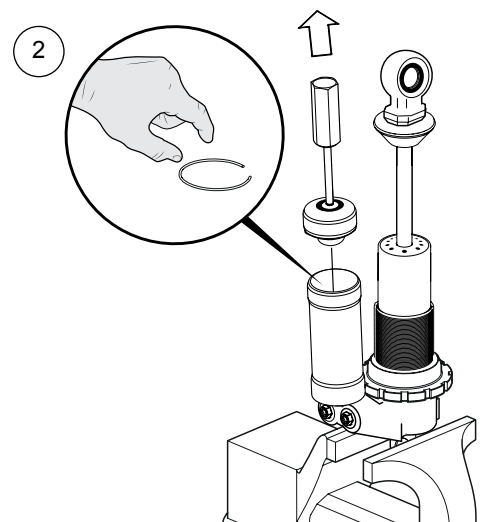

6.1.3

Use Disassembly tool, end cap (00720-03) to pull the separating piston out.

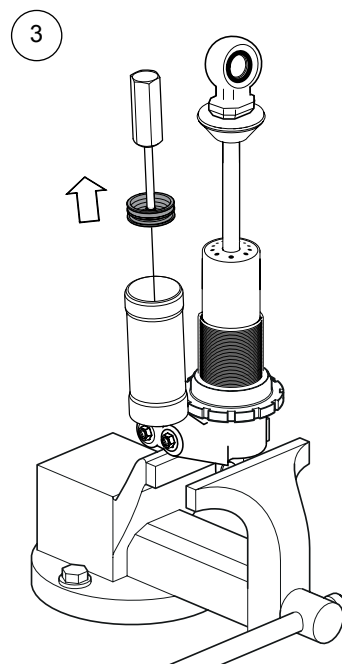

6 - REPLACE SEPARATING PISTON SEAL

6.1.4

Remove the old separating piston seal and the reservoir end cap o-ring.

Note!

There are different versions of separating piston seal. Some versions use an o-ring and some use an x-ring.

4

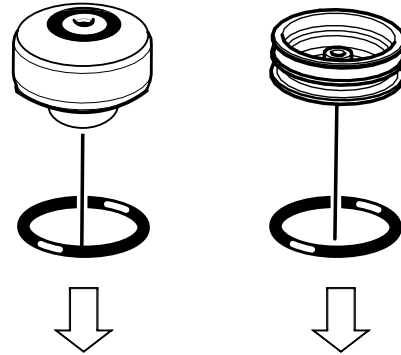

6.2 Assemble

6.2.1

Apply grease to the new separating piston seal and install.

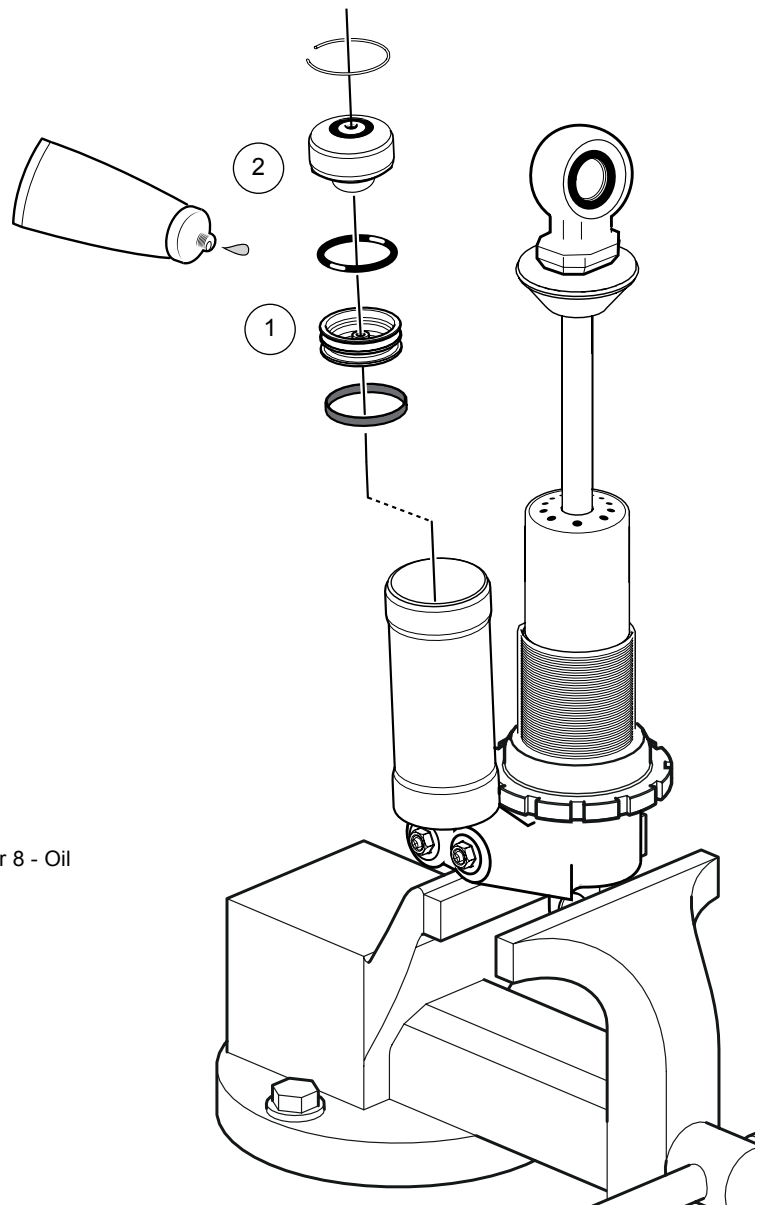

6.2.2

Apply grease to the new reservoir end cap o-ring and install.

6.2.3

Install Separating piston and Reservoir end cap. See chapter 8 - Oil Fill Procedure.

7 - CHANGE VALVE SPECIFICATION

7.1 Disassemble

7.1.1

Release gas pressure, see chapter 1 - Pressure.

7.1.2

Put the damper in a vise with the valve train axis pointing vertically.

7.1.3

Note the clicker settings.

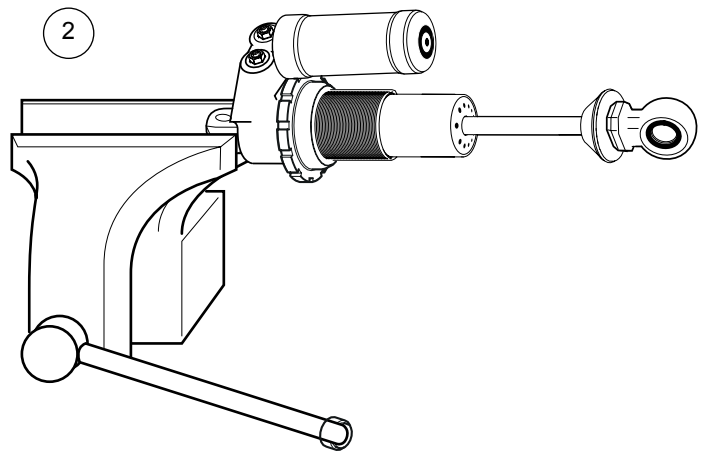

7.1.4

Adjust the high speed adjuster to the half way position.

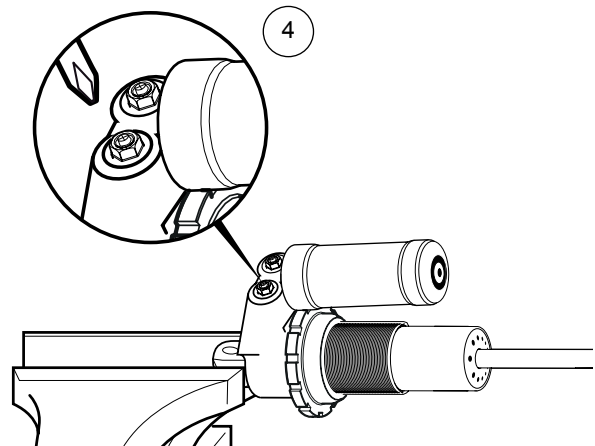

7.1.5

Remove the circlip. A dental pick and razor blade are helpful when doing this.

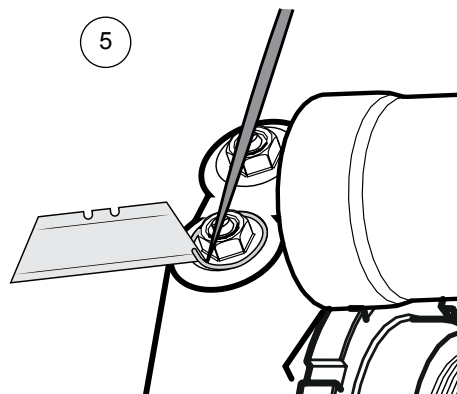

7 - CHANGE VALVE SPECIFICATION

7.1.6

Unscrew the high speed adjuster.

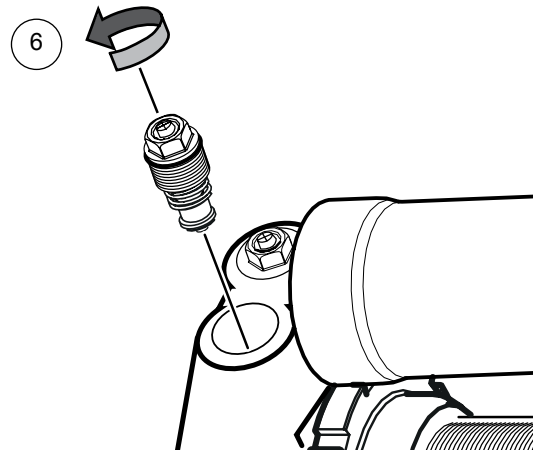

7.1.7

Remove the high speed adjuster, spring and poppet.

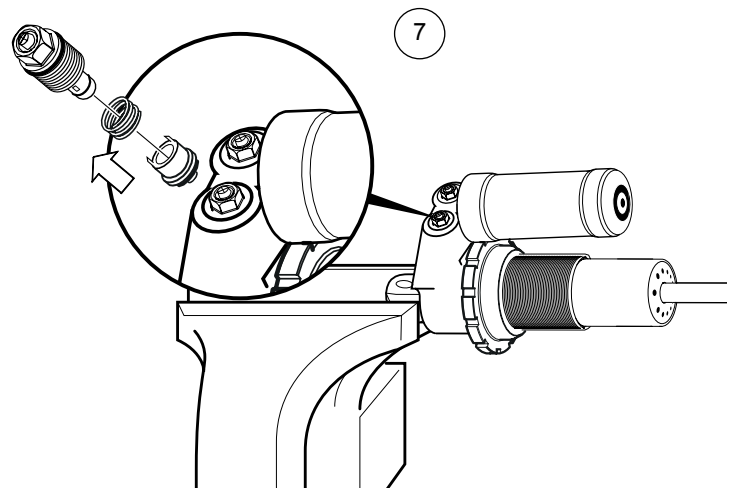

7.1.8

Fill valve port to the top with new fluid.

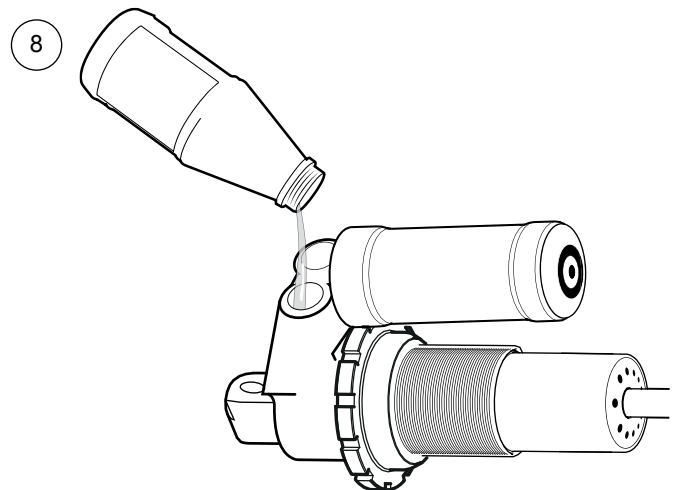

7 - CHANGE VALVE SPECIFICATION

7.2 Assemble

7.2.1

Replace the poppet guide o-ring and high speed adjuster o-ring.

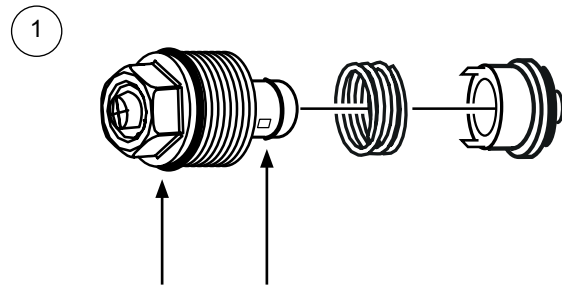

7.2.2

Select the valving desired and install.

Note!

Fluid should squirt out of the adjuster bleed hole.

7.2.3

Pressurize, see chapter 1 - Pressure.

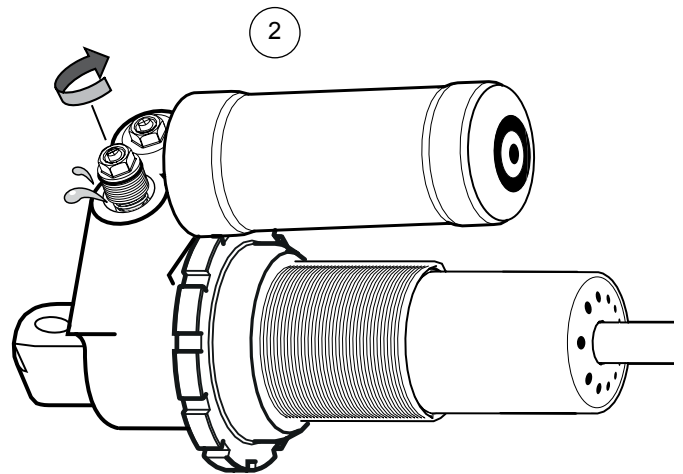

8 - OIL FILL PROCEDURE

👁 **Note!**

To start this procedure, the valves, separating piston, shaft assembly and inner tube should be removed from the damper. See prior sections for these instructions..

8.1

Put the damper in the vise with the valve train port axis pointing vertical and fill with damper fluid until the valve ports are completely full.

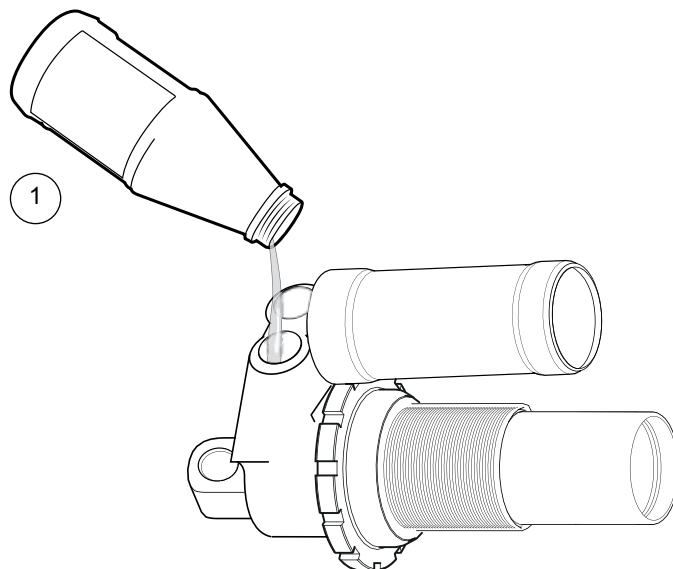

8.2

Screw in the adjusters just until you can no longer see the o-ring, so as to not preload the valve springs.

👁 **Note!**

Fluid should squirt out of the adjuster bleed hole.

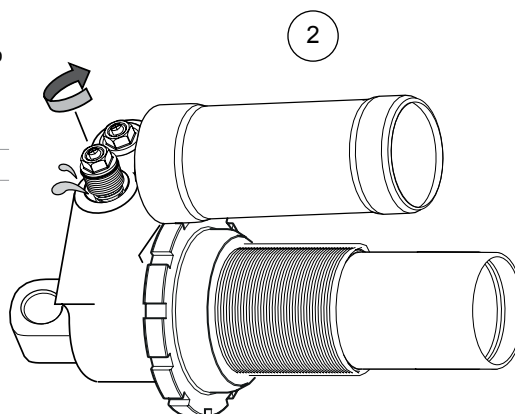

8.3

Turn the damper up in the vise with the cylinder tube axis pointing vertical and fill until the external reservoir tube is full.

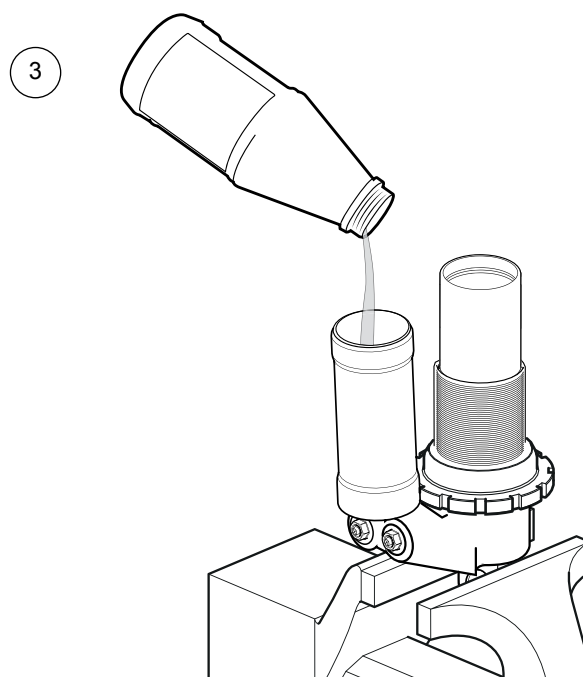

8 - OIL FILL PROCEDURE

8.4

Insert the separating piston using the Disassembly tool, end cap (00720-03). Be careful not to trap any air.

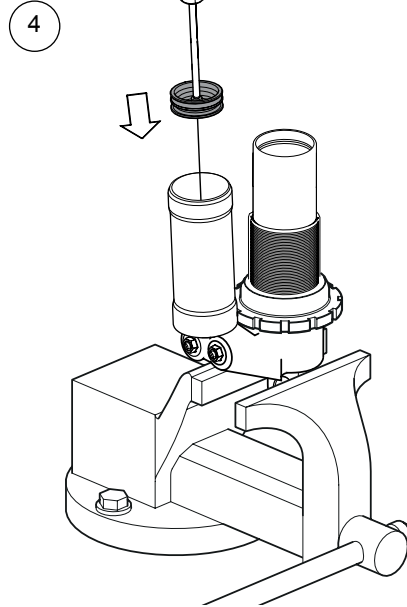

8.5

Push down until you have reached the bottom and zero your caliper on the measurement from the edge of the external reservoir tube to handle of end cap tool.

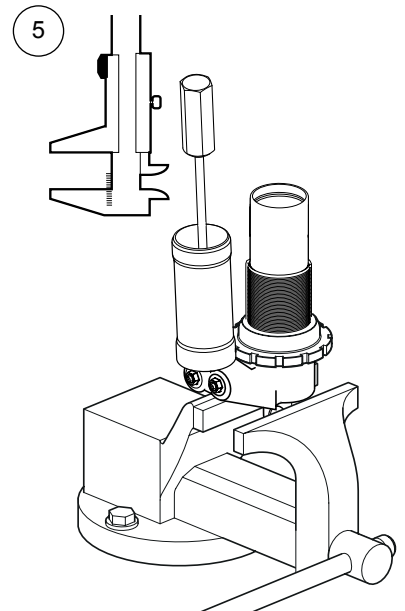

8.6

Pull the separating piston up 2 mm.

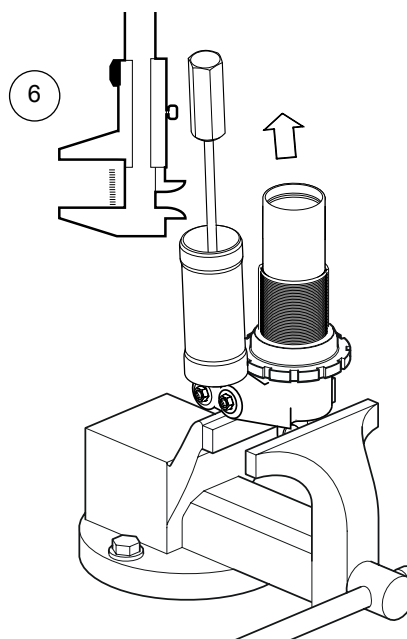

8 - OIL FILL PROCEDURE

8.7

Wrap the piston band with the Piston install o-ring (00338-40).

7



8.8

Insert the inner tube.

8

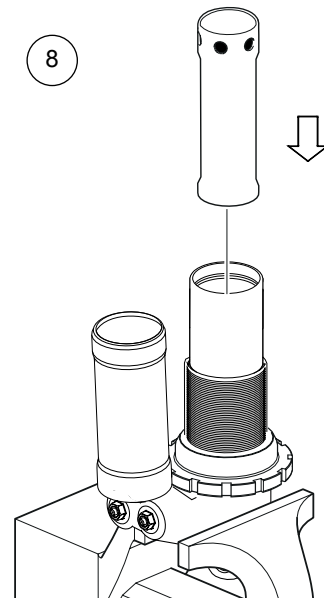

8.9

Fill the cylinder tube and inner tube with damper fluid up to the top of the inner tube.

9

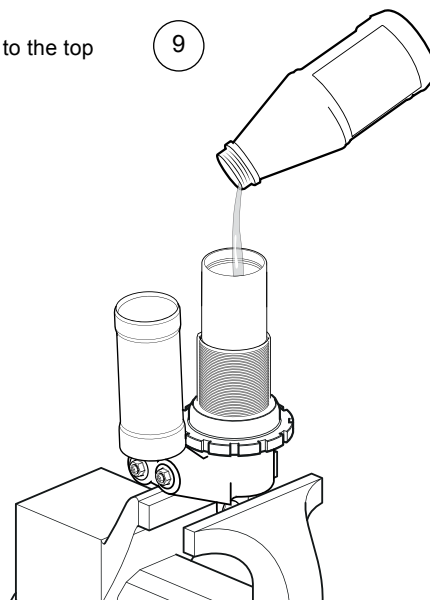

8 - OIL FILL PROCEDURE

8.10

Carefully insert the piston into the inner tube. The installed o-ring should slide off towards the end eye.

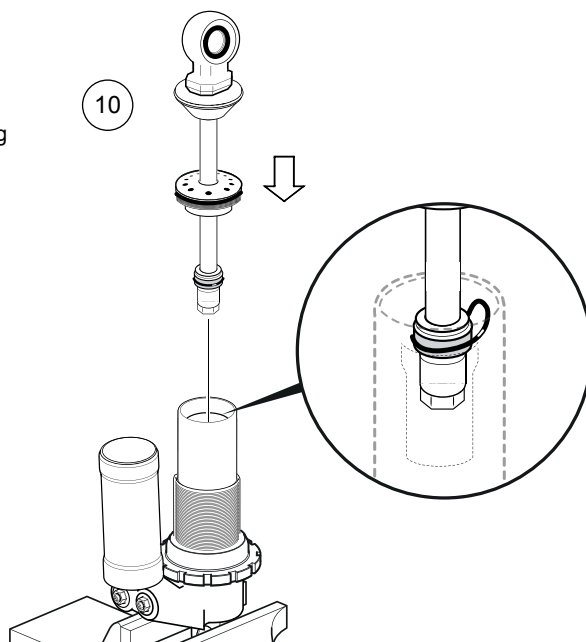

8.11

Without pulling the piston out of the inner tube stretch the install o-ring over the seal head, bump rubber and end eye. Or you may cut the o-ring to remove it. (Tip: If you have performed a rebuild and left off the seal head and end eye you can remove the o-ring much easier. Once the o-ring has been removed, install the seal head. See chapter 4 Replace Seal Head

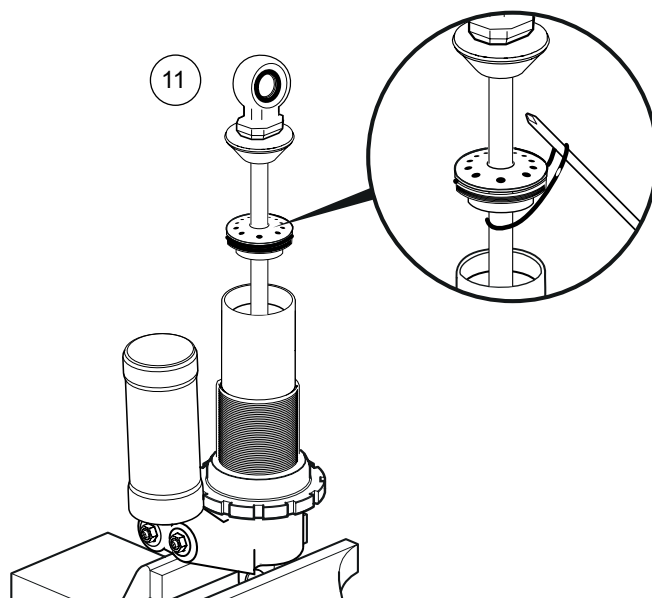

8.12

Place the main piston at fully extended without removing the piston from the inner tube, and fill the cylinder tube with damper fluid.

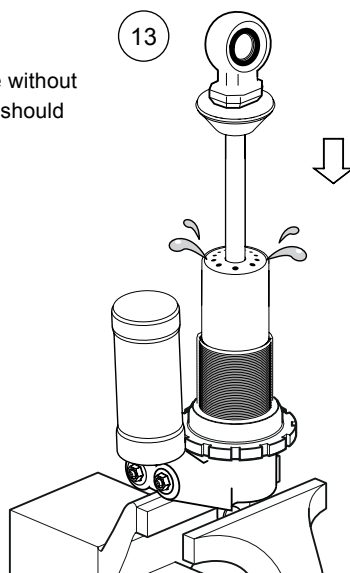

8.13

Slide the seal head down the shaft and into the cylinder tube without allowing the piston to move in the inner tube. The seal head should squeeze fluid out.

8 - OIL FILL PROCEDURE

8.14

Tighten the seal head to a torque of 20 Nm. Be sure to have the torque wrench 90° to the pin spanner otherwise the actual torque applied will be different from that measured. (Tip: If you performed a rebuild and left off the end eye you can install it now, see chapter 3 - Replace End Eye).

ⓘ Note!

When installing the seal head the separating piston will move approximately 5 mm from the oil displaced from the seal head.

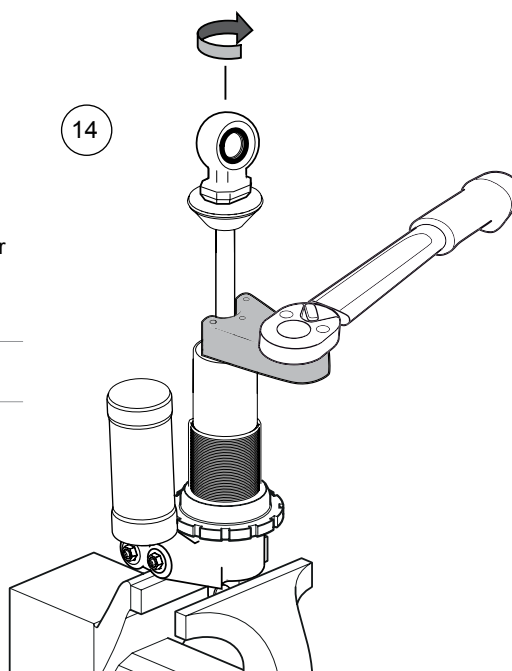

8.15

Screw the high speed adjusters to the half way position and install the circlips.

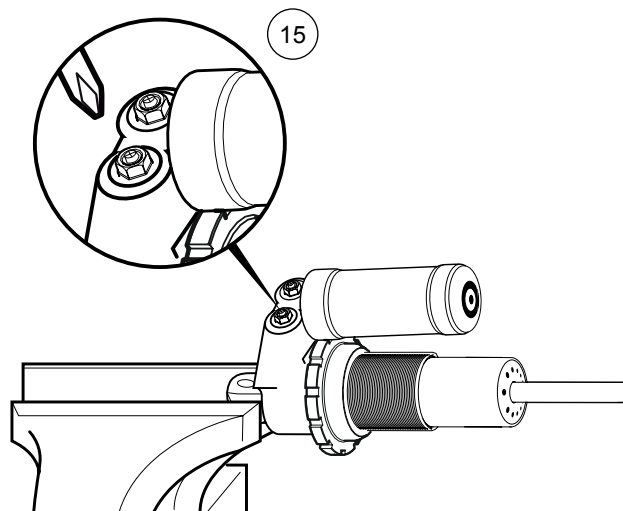

8.16

Install the external reservoir end cap and circlip. Use Disassembly Tool, End cap (00720-03).

8.17

Pressurize, see chapter 1 - Pressure.

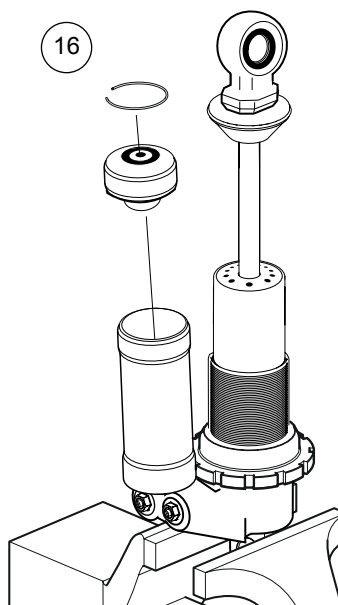



[This page is intentionally left blank.]

Your Öhlins retailer:



Öhlins Racing AB
Box 722
SE-194 27, Upplands Väsby
Sweden

Phone: +46 (0)8 590 025 00
Fax: +46 (0)8 590 025 80
www.ohlins.com



www.ohlins.com