

DH38 Front Fork

***FG38xx 19xx /
FDxxx 38xx 21xx***

Owner's Manual





Öhlins Headquarters Upplands Väsby, Sweden

Öhlins Racing AB - The Story

It was the 1970's, a young man named Kenth Öhlin spent most of his spare time pursuing his favourite sport: motocross.

Being a careful observer, Kenth's attention was continuously drawn to one specific detail - motocross bikes had more engine power than their suspension could handle. It was not long before Kenth realised that better performance could be achieved by improved wheel suspension.

Öhlins Racing was established in 1976, and just two years later the company won its first World Championship title. Despite being in the business for almost 40 years, the search for perfection and new functions is still the main focus of the company.

Congratulations! You are now the owner of an Öhlins product. More than two hundred World Championships and other major world titles are definitive proof that Öhlins products offer outstanding performance and reliability.

Every product has gone through rigorous testing and engineers have spent thousands of hours, doing their very best to use every possible experience from our almost 40 years within the racing sport.

The product that you now have in your possession is pure racing breed that is built to withstand.

By installing this product on your bike you have made a clear statement... you are a serious rider with a focus on getting the maximal handling ability and outstanding feedback from your bike. Along comes the fact that your Öhlins product will be a long lasting friend, delivering the very best of comfort and performance every time you go for a ride. Go explore!

SAFETY PRECAUTIONS

General Warnings

Note!

The fork is an important part of the bicycle and will affect the stability.

Note!

Read and ensure you understand the information in this manual and other technical documents provided by the bicycle manufacturer before using the product.

Note!

Öhlins Racing AB can not be held responsible for any damage to the shock absorber, bicycle, other property or injury to persons, if the instructions for mounting, usage and maintenance are not followed exactly.

Warning!

After you have installed the Öhlins product, take a test ride at low speed to ensure that the bicycle has maintained stability.

Warning!

If the suspension makes an abnormal noise, or the function is irregular, or if you notice any leakage from the product, stop the bicycle immediately and return the product to an Authorized Öhlins MTB Service Center.

Warning!

The product warranty shall only apply if the product has been operated and maintained in accordance with recommendations in this manual. If you have any questions regarding usage, service, inspection and/or maintenance please contact an Authorized Öhlins MTB Service Center.

Note!

When working with the Öhlins product, always read the bicycle manufacturer's manuals.

Note!

This manual shall be considered as a part of the product and shall therefore accompany the product throughout its life cycle.

SAFETY SYMBOLS

In this manual, mounting instructions and other technical documents, important information concerning safety is distinguished by the following symbols:



The Safety Alert Symbol means: Warning! Your safety is involved.

Warning!

The Warning Symbol means: Failure to follow warning instructions can result in severe or fatal injury to anyone working with, inspecting or using the Product/Fork, or to bystanders.

Caution!

The Caution Symbol means: Special precautions must be taken to avoid damage to the Product/Fork.

Note!

The Note Symbol indicates information that is important regarding procedures.

Warning!

This product was developed and designed exclusively for bicycles and shall only be installed on intended bicycle models in its original condition as delivered from the bicycle manufacturer.

Warning!

This product contains pressurized air. Do not open, service or modify this product without proper education and proper tools. All hydraulic servicing must be completed by an Authorized Öhlins MTB Service Center. All other servicing must be completed by an Authorized Öhlins MTB Service Center alternatively you can conduct the service yourself if you have the necessary skills, genuine parts and tools. In some cases the product may need to be sent to another region for service.

© Öhlins Racing AB. All rights reserved. Any reprinting or unauthorized use without the written permission of Öhlins Racing AB is prohibited.



THE ÖHLINS DH38 FRONT FORK

Congratulations on your excellent choice of purchasing this high performance Öhlins front fork.

This product is designed for the upcoming, next generation of stars and has been developed by Öhlins' mountainbike department in Sweden, with their experience from the world stars of today.

We recommend you to read this manual carefully for proper bike set up to get the best possible performance out of your suspension components.

Contents

Safety precautions	3
The Öhlins cartridge kit	4
1 How it works	5
2 Mounting instructions	6
3 Adjusters	9
To set the adjusters	9
Compression damping adjuster	9
Rebound damping adjuster	9
4 Setting sag	10
5 Setting up	11
6 Inspection and maintenance	12

1 HOW IT WORKS

To get your suspension set up correctly the front fork and shock absorber must be in balance. To achieve this, both must be considered when setting up the new product.

To set up the fork there is two systems to consider.

Spring

The main purpose of the spring is to support the rider and bike and restore the set ride height after impact.

Setting up your sag is the most important aspect of tuning your fork, and this is done by correctly tuning your air spring. Sag is the percentage of suspension travel that is used when you assume normal, static riding position on the bike. See separate chapter for air spring setup procedure.

Hydraulic damping

The damping controls the forks movement in compression and in rebound by converting the kinetic energy in to heat. Valves and shim stacks are used to regulate the oil flow and thus controlling the amount of damping.

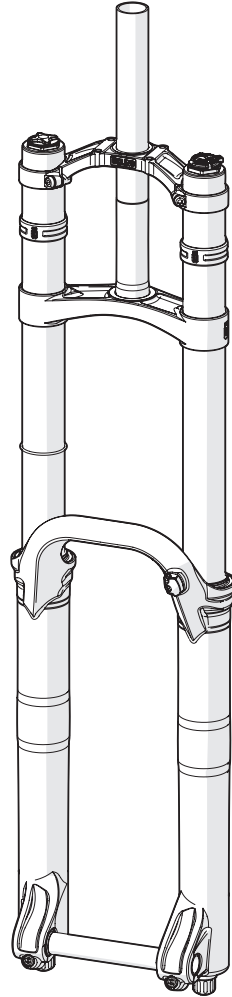

2 MOUNTING INSTRUCTIONS

⚠ Warning!

It is advisable to have an Authorized Öhlins MTB Service Center install the front fork.

⚠ Warning!

If the bicycle is mounted in a work stand please make sure to hold the frame when front fork is removed to prevent damage to paint and (or) finish.

👁 Note!

Before installing this product clean the bicycle thoroughly.

👁 Note!

When working on this product, always see the bicycle service manual for specific procedures and important data.

👁 Note!

Choose the appropriate crown set. The straight top crown is recommended for 27.5" tires and the tall top crown for 29" tires. Choose crown set offset according to the frame manufacturer's recommendations.

1

Remove the original front fork.

2

Place the Öhlins DH38 fork crown in the bike Head tube. Do not use more than 30 mm of spacers under the top crown. Tighten the headset according to manufacturer's instructions.

3

Insert the Stanchions into the Crown. Install the rubber Fork bumpers on each Stanchion between the Top and Bottom crown. Position the bumpers to protect stanchions and frame from damage as the handlebar is turned.

Tip: Apply a small amount of water to the inside of the Fork bumper for easier installation.

4

27.5" tires: Position the Bottom crown at a minimum of 202 mm* from Wiper seal, starting with Spring side Stanchion.

29" tires: Position the Bottom crown at a minimum of 220 mm* from Wiper seal, starting with Spring side Stanchion.

** Dimensions valid for 200 mm travel forks, see figure and chart on page 11.*

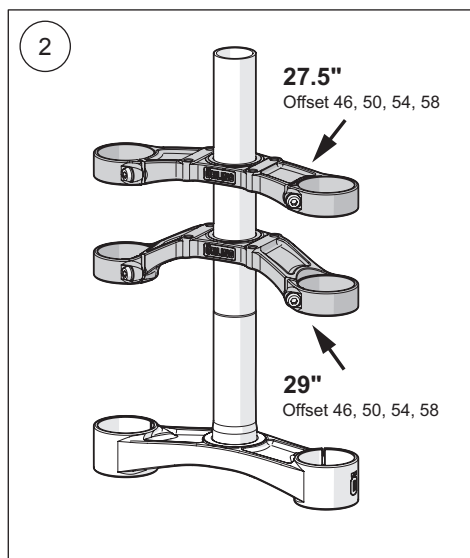

2 MOUNTING INSTRUCTIONS

5

Tighten the Bottom crown bolts. Tighten ① to 8 Nm, then tighten ② to 8 Nm. Proceed by alternately tightening ① and ② to 8 Nm until both ① and ② has been tightened a minimum of 3 times. Repeat this procedure on ③ and ④.

⚠ Warning!

If bottom crown is mounted to low the crown will make contact with wheel when bottoming. Always remove air and compress the fork fully after mounting to ensure proper wheel clearance.

6

Tighten headset according to manufacturer's instructions.

7

Tighten middle clamp bolt of Top crown to 8 Nm.

8

Tighten the remaining Top crown bolts to 8 Nm.

9

Remove Air from air spring and compress fork fully. If there is less than 12 mm of clearance between crown and tire, inflate Airspring and redo step 4-8.

10

Install the brake caliper according to the brake manufacturer's instructions. Do not use a disc rotor larger than $\varnothing 203$ mm.

👉 Caution!

Ensure that all screws are tightened to the correct torque and that nothing fouls or restricts movement of the front fork when the suspension is fully compressed or extended. Please check suitable clearance between the fork and frame when turning.

⚠ Warning!

Use a suitable Crown Race and bearing.

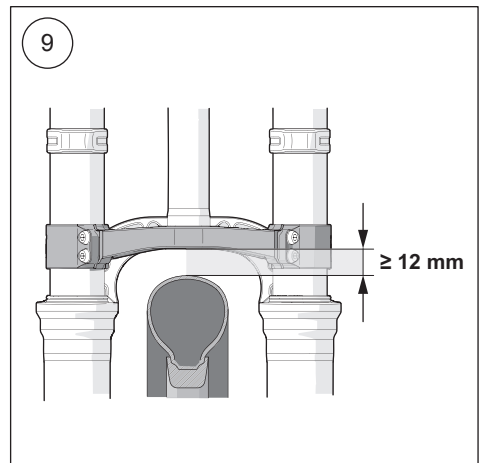
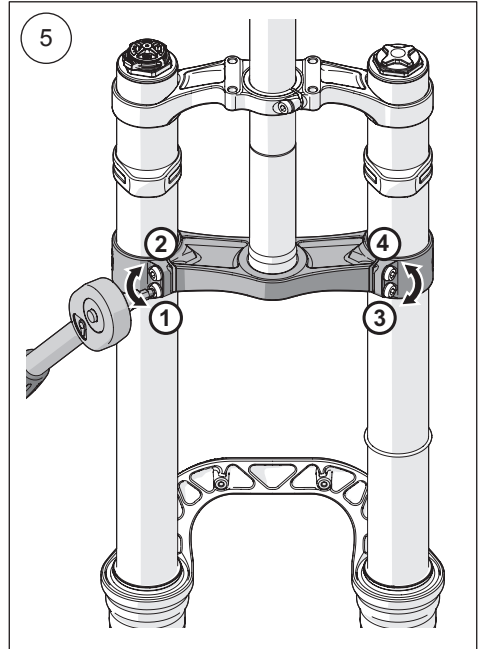

2 MOUNTING INSTRUCTIONS

11

Attach the brake cable to the hose clamp and tighten the screw. Use a 2.5 mm Hex wrench. Tighten the bolt to 0.5 Nm.

12

Apply Grease on wheel shaft and shaft threads before installation. Use a 5 mm Hex wrench to tighten the Wheel Shaft A before screw B and then finally screw C. Tighten A, B and C to 6 Nm.

⚠ Caution!

Ensure that all screws are tightened to the correct torque and that nothing fouls or restricts movement of the front fork when the suspension is fully compressed or extended.

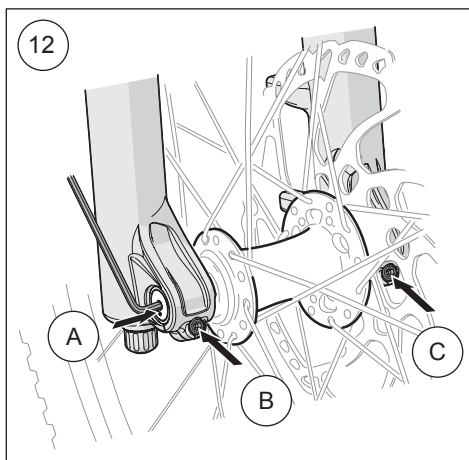
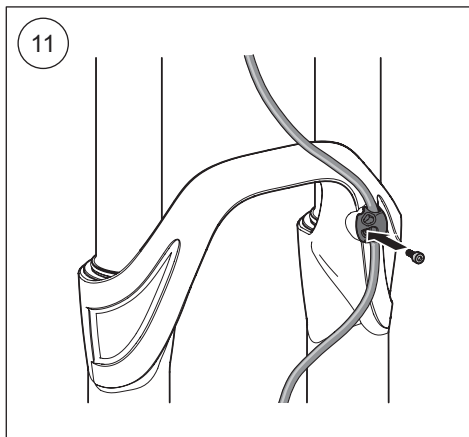

3 ADJUSTERS

Compression damping controls the energy absorption when the front fork is being compressed, thus controls how easily the front fork compresses when you hit a bump. Rebound damping controls the energy absorption when the front fork is being extended and controls how fast the front fork returns to its normal position after being compressed.

To set the adjusters

Turn the adjuster clockwise to fully closed position. Then, turn counter clockwise to open, and count the clicks until you reach the recommended number of clicks.

⚠ Caution!

*Turn gently not to damage delicate sealing surfaces.
Tighten with your hand only.*

Compression damping adjuster

1. Adjust low speed

To adjust, turn the blue coloured adjuster on the top of the TTX cartridge. Turn clockwise to increase damping, turn counter clockwise to decrease.

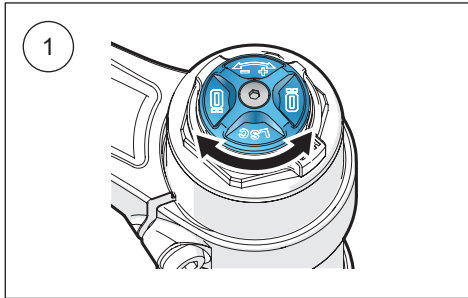

2. Adjust high speed

To adjust, turn the black coloured adjuster on the top of the TTX cartridge. Turn clockwise to increase damping, turn counter clockwise to decrease.

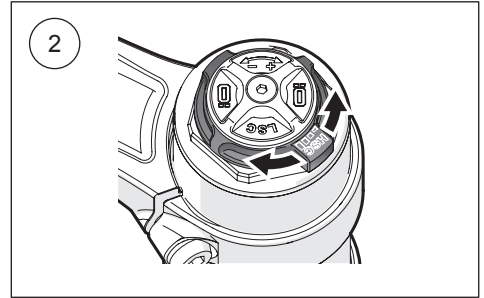

Rebound damping adjuster

3. Adjust rebound

Turn the gold coloured adjuster on the end eye/ bracket. Turn clockwise to increase damping, turn counter clockwise to decrease.

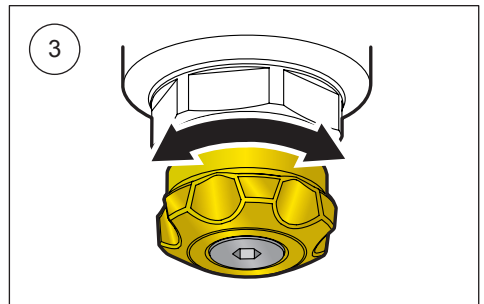

4 SETTING SAG

Setting sag is a crucial part of setting your bicycle since it affects the height of the bicycle and the fork angle. In the following chapter we will describe how to set the sag.

Note!

This procedure must be performed on a flat surface. Do not jump or bounce on your bicycle as it will result in an inaccurate sag measurement.

Setting sag:

1
Unscrew the cap to the lower valve (ramp up chamber) and assemble the air pressure pump. Pump to desired pressure. Disconnect the pump and put the cap back on.

2
Unscrew top air cap (Main chamber) and assemble the air pump. Pump to desired pressure. Disassemble the air pump and reinsert the compression air cap.

3
Push the O-ring (sag indicator) down to the dust wiper.

4
Dressed in full riding gear assume normal riding position on the bicycle.

5
Step off the bicycle and measure the distance the O-ring (sag indicator) has moved. Sag should be set to approximately 20-25 % of the fork travel.

General recommendations:

- too little sag: release air from main chamber
- too much sag: fill up with more air in main chamber

General recommendations:

Heavy hard charging rider may require less sag while a smoother rider may benefit from more sag. If you have any questions, contact an Authorized Öhlins MTB Service Center for advice.

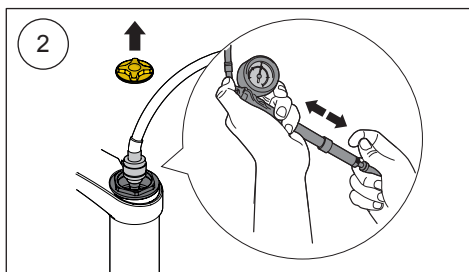
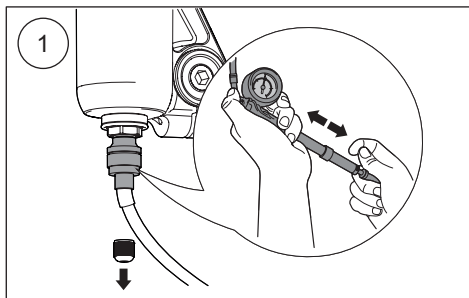

5 SETTING UP

Reset to original ride position

If the air pressure in the main chamber has been reduced, it is necessary to reset the fork to its original length.

Example: If you are lowering the pressure from 130 psi to 80 psi, the fork will get a lower ride position (shorter travel). Reset the fork to original Ride position by extending the fork by pulling the handlebar up, while your friend is holding the wheel tight to the ground. Repeat the extension about 10 cycles, until you have reached the original length.

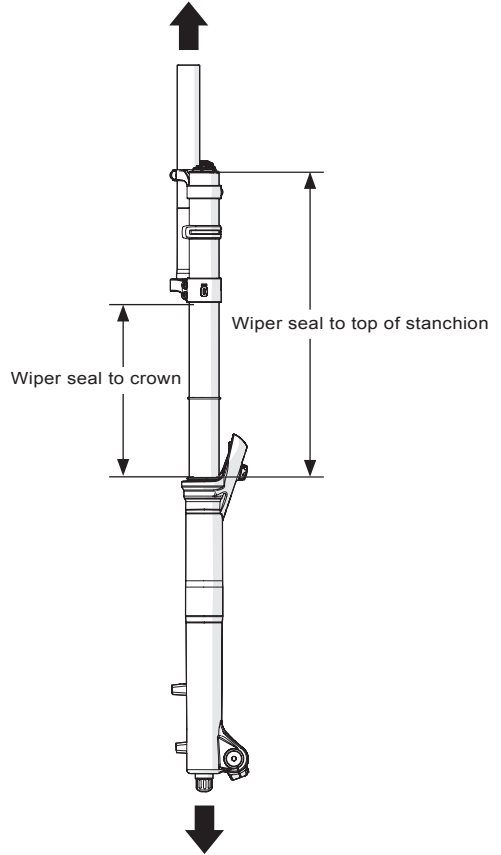

Original distance between wiper seal and top of stanchion:

Wheel size	Fork travel [mm]	Wiper seal to top of stanchion [mm]	Minimum distance wiper seal to crown [mm]
29"	180	368	200
29"	200	388	220
27.5"	180	368	182
27.5"	200	388	202

6 INSPECTION AND MAINTENANCE

Preventive maintenance and regular inspection reduces the risk of poor function. If there is any need for additional service, please contact an Öhlins dealer.

Recommended Service Intervals

Extreme riding in adverse weather conditions or lack of cleaning will shorten service intervals.

Maintenance	Interval
Clean dirt and debris from front fork	Every ride
Check air pressure and set sag	Every ride
Check torque on front fork mounting bolts	Every ride
Remove lowers, clean and inspect bushings and seals, change oil bath if necessary	50 hours
Full front fork air spring service	100 hours/1 year
Remove and clean lowers, replace seals and bump rubbers, change oil bath	100 hours/1 year
Full front fork damping cartridge service	100 hours/1 year

Disposal

Hand over your discarded Öhlins product to an Öhlins dealer for proper disposal.







Your Öhlins retailer:

Öhlins Racing AB
Box 722
SE-194 27, Upplands Väsby
Sweden

Phone: +46 (0)8 590 025 00
Fax: +46 (0)8 590 025 80
www.ohlins.com

