



MkI/MkII Automotive

TTX40/ TTX46MT

Owner's Manual



Safety Precautions

Note!

The shock absorber is a very important part of the vehicle and will therefore affect the stability of the vehicle.

 *Read and make sure that you understand the information in this manual and the mounting instructions before you use this product. If you have any questions regarding installation or maintenance please contact your nearest Öhlins dealer.*

 *Öhlins Racing AB can not be held responsible for any damage to the shock absorber, vehicle, other property or injury to persons, if the instructions for installing and maintenance are not followed exactly.*

Warning!

This product was developed and designed exclusively for a specific vehicle model and should only be installed on the intended vehicle model in its original condition as delivered from the vehicle manufacturer.

 *The specifications for the particular shock absorber are results from tests run on a factory equipped vehicle. If wheel dimensions, springs and/or other chassis parts have been changed or modified, the clearances and vehicle stability can be affected.*

 *This product contains pressurized nitrogen gas (N₂). Do not open, service or modify this product without proper education (authorized Öhlins dealer/distributor) and proper tools.*

 *After installing this product, take a test drive at low speed to make sure that your vehicle has maintained its stability.*

 *If the suspension makes an abnormal noise, or the function is irregular, or if you notice any leakage from the product, please stop the vehicle immediately and return the product to an Öhlins Service Centre.*

Note!

When working on this product, always read your Vehicle Service Manual.

 *This Manual should be considered a part of the product and should therefore accompany the product throughout its life cycle.*

Safety Symbols

In this manual, mounting instructions and other technical documents, important information concerning safety is distinguished by the following symbols:



The Safety Alert Symbol means: Warning! Your safety is involved.

Warning!

The Warning Symbol means: Failure to follow warning instructions can result in severe or fatal injury to anyone working with, inspecting or using the shock absorber, or to bystanders.

Caution!

The Caution Symbol means: Special precautions must be taken to avoid damage to the shock absorber.

Note!

The Note Symbol indicates information that is important regarding procedures.

© Öhlins Racing AB. All rights reserved. Any reprinting or unauthorized use without the written permission of Öhlins Racing AB is prohibited.
Printed in Sweden.

	Page
Safety Precautions	1
1 - Introduction	3
2 - General description	4
3 - Damping force measurement	13
4 - Damping curve terminology	16
5 - External adjusters	17
6 - Limits in force and velocity	21
7 - Matching of damping force	21
8 - Hysteresis	22
9 - Cavitation	24
10 - Friction level	26
11 - Temperature stability	27
12 - Damper functions	28
13 - Damping guidelines	30
14 - Gas pressure	31
15 - Temperature range	31
16 - Routine maintenance	32
17 - Actions after a crash or fire	33
18 - Valving reference program	34
19 - Damper configuration	35
20 - Damper dimensions	39
21 - Damper identification	54
22 - Technical data	54
23 - Optional parts	55

1 - Introduction

Congratulations on choosing the Öhlins TTX40/ TTX46 MT damper, the latest generation of twin tube dampers from Öhlins.

Get to know your TTX40/ TTX46 MT, and be sure to read this manual thoroughly before using the dampers. We recommend that you keep this manual handy.

The TTX40/ TTX46 MT damper is the culmination of three decades of Öhlins' successful participation in world championship events winning more than 200 World Championships. Many years of work together with some of the world's most successful racing teams together with advanced dynamic analysis methods developed at Öhlins Racing headquarter in Sweden has given Öhlins the unique knowledge needed to design the TTX40/ TTX46 MT damper.

The Öhlins TTX40/ TTX46 MT damper, originally developed for formula racing, is designed to handle the demanding damping characteristics needed for all types of tracks, from street courses to super speedways. The TTX40/ TTX46 MT damper is fully adjustable with maximised damper response together with qualities you've never seen before when it comes to "settings".

Low and high speed compression and rebound damping are externally adjustable and fully independent. The adjustment range is huge with equal increments of force throughout the adjustment range. Even the shape of the damping curve can easily be changed. All adjusters affect the flow from the main piston, not the piston rod displacement volume.

The compression damping forces of the TTX40/ TTX46 MT damper are not, as in a conventional damper, caused by a pressure drop on the rebound side, but by increased pressure on the compression side. This reduces the risk of cavitation and makes any reservoir valve or high gas pressure unnecessary. So, no balancing of reservoir damping to main piston damping is needed to avoid cavitation and improve damping response.

Maximum response and minimum risk of cavitation will always occur. With no reservoir valve, the internal pressure of the damper unit will be kept to a minimum.

The low amount of hysteresis results in excellent short stroke/high force performance. Also, a very low gas pressure can be used without any loss of damping performance.

Along with the damper comes a unique Valving Reference Program (available for download free of charge at www.ohlins.com). Make sure to choose the correct one for your damper (MkI/MkII).

This computer model of the damper will allow you to find damping curves without a dynamometer. It will reduce building time tremendously and allow exact damper adjustments in pit lane. The TTX40/ TTX46 MT product will revolutionise the work for mechanics and engineers in the racing business.

This manual text is based on TTX40/ TTX46 MT dampers. These are through rod type dampers loaded with several new concepts. As always, all dampers are tested before they are delivered to the customer. In keeping with Öhlins long tradition of perfection, quality is outstanding and long life is to be expected.

Welcome to the World of Öhlins.

Figure 1.1

Complete TTX40 and TTX46 MT MkII dampers without springs.



The compression damping cycle describes the situation when the rod and piston unit moves into the damper body shortening the length of the damper. While the rebound damping cycle describes the situation when the rod and piston unit moves out from the damper body extending the length of the damper.

The terminology "compression side" of the piston here refers to the oil volume in front of the piston when the external piston rod is moving into the damper body (compression cycle). The "rebound side" of the piston refers to the oil volume in front of the piston when the external piston rod is moving out of the damper body (rebound cycle).

When the rod and piston unit doesn't move, the internal pressure in the whole damper unit is equal with the set gas pressure. When track conditions cause the vehicle suspension to move, the damper piston will attempt to move through the damper oil. In order for the piston to move, oil must flow from one side of the main piston to the other. The restriction of the valves causes a pressure difference between the two sides of the piston, resulting in damping forces. In the TTX40/TTX46MT, this pressure difference comes from increased pressure on the forward side of the piston and not reduced pressure on the backside, as in conventional dampers.

Unless a different valve configuration is used compression to rebound, the compression and rebound valves are identical (exceptions are model specific dampers like the BMF and POF dampers). On both sides in the MkI there are three types and in the MkII there are two types of valves used for adjusting the damping characteristics.

- Bleed valve (MkI/MkII)
- Shim valve (MkI/MkII)
- Poppet valve (MkI)

Valve description - TTX40/TTX46MT MkI

The compression bleed valve (low speed) is in parallel with the compression poppet valve (high speed) and the rebound bleed valve (low speed) is in parallel with the rebound poppet valve (high speed). The poppet valves are pushed against their seats by preloaded coil springs.

The preload is externally adjustable. The amount of preload of the poppet valves determines the pressure differentials across the main piston necessary to make the poppet valves open. For more information about the bleed valves and the poppet valves, see chapter *External adjusters*.

The shim valves are placed on the nose of the poppet valves. These shim stacks affect the opening characteristic of the poppet valves. The shim configuration can be changed to achieve different opening characteristics of the poppet valve. Also, there are two check valves installed in the damper, making the compression and rebound valves fully independent.

Valve description - TTX40/TTX46MT MkII

The compression bleed valve (low speed) is in parallel with the compression shim valve (high speed) and the rebound bleed valve (low speed) is in parallel with the rebound shim valve. The shim stacks are pushed against their valves by preloaded coil springs. The preload is externally adjustable. The amount of preload of the shim stacks determines the pressure differentials across the main piston necessary to make the shim valves open. For more information about the bleed valves and the shim valves, see chapter *External adjusters*.

The combination of shims on the valve affect the opening characteristic of the valves. Also, there are two check valves installed in the damper, making the compression and rebound valves fully independent.

Figure 2.1

Compression and Rebound damping cycle TTX40

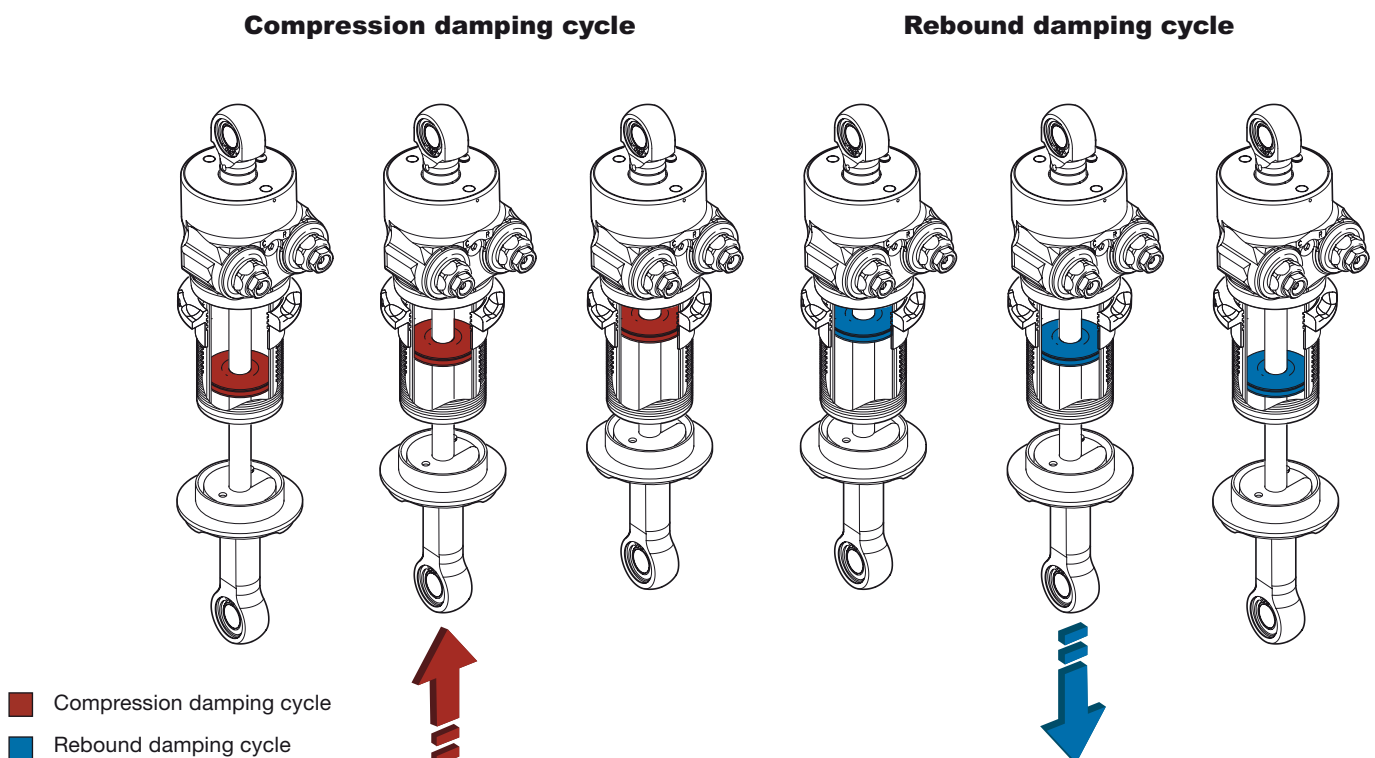

2 - General Description

Flow circuit at compression cycle

How the oil flows from the compression side to the rebound side of the piston will be described here. This is caused by increased pressure on the compression side of the main piston, while the pressure on the rebound side is almost constant at the set gas pressure.

1a. TTX40

The oil will reach the compression valves by passing through the port of the separating plate (fig. 2.3-A and 2.7-A) extending into the cylinder head and leading the oil into a chamber below the compression valves (fig. 2.3-B, 2.7-B and 2.8a-B). Because of the small restriction of this port, the pressure in this chamber will be very much the same as the compression side of the cylinder tube. The piston velocity and how the valves are set determine the pressure in the chamber. The pressure will help to close the check valve in this chamber.

1b. TTX46MT

The oil will reach the compression valves by passing through the holes in the outer tube (fig. 2.11-A) extending into the valve housing and leading the oil into a chamber below the compression valves (fig. 2.11-B). Because of the small restriction of this port, the pressure in this chamber will be very much the same as the compression side of the cylinder tube. The piston velocity and how the valves are set determine the pressure in the chamber. The pressure will help close the check valve in this chamber.

2. TTX40/ TTX46 MT

Depending on the pressure, different things will occur. As the velocity increases, the pressure will rise.

2a. TTX40/ TTX46 MT

In the initial part of a compression stroke, when the velocity of the piston is low, the oil will pass through the adjustable low speed compression bleed valve. In this bleed valve, the restriction takes place in the passage (fig. 2.3-C, 2.6a-C, 2.7-C, 2.10a-C and 2.11-C) between the needle seat (integrated to the needle housing) and the needle. As long as the piston is moving and the bleed valve is not fully closed, some oil will always flow through the bleed valve. If the bleed valve is fully closed, this passage will be blocked.

2b.1 TTX40/ TTX46 MT Mki

As the velocity increases, the shim stack on the nose of the poppet valve will start to open and oil can pass between the shim stack and the poppet valve seat (fig. 2.2-D and 2.3-D). The stack configuration will decide the opening pressure. An increased stiffness of the stack will raise the opening pressure and thus raise the damping force. The shape of the nose on the poppet valve gives the shims freedom to bend and lift from the seat, no matter how much preload from spring there is on the poppet valve. This will allow the shim stack to always open gradually and therefore a small amount of oil will pass through the shim stack even with a very low pressure drop over the piston.

2b.2 TTX40/ TTX46 MT MkII

As the velocity increases, the shim on the valve will start to bend and the valve will start to open and oil can pass between the shim stack and the valve (fig. 2.6a-D, 2.7-D, 2.10a-D and 2.11-D). The stack configuration will decide the opening pressure. All shims with a larger diameter than 20 mm will affect the initial opening of the stack. An increased stiffness of the stack will raise the opening pressure and thus raise the damping force. This will allow the shim stack to always open gradually and therefore a small amount of oil will pass through the shim stack even with a very low pressure drop over the piston.

2c.1 TTX40/ TTX46 MT Mki

As the piston velocity increases further, the internal pressure rises. At a certain velocity the movement of the piston creates a pressure difference across the main piston that is equal to the predetermined pressure required to open the poppet valve. The oil is now free to flow between the poppet valve and the seat (fig. 2.2-E and 2.3-E). Due to the oil flow, the nose shims will follow the poppet valve up from the seat.

Note!

In practice, the piston often does not reach a velocity high enough to cause a sufficient pressure drop and open the poppet valve.

By using a very stiff shim stack in combination with little preload on the poppet valve, the oil flow through the shim stack will be very limited before the poppet valve opens. This will make the opening of the poppet valve more abrupt and the shim stack will open at a higher velocity. This will change the characteristics of the damping curve.

Note!

The opening characteristic of the poppet valve is always abrupt, unlike the gradual opening characteristic of the shim stack.

2c.2 TTX40/ TTX46 MT MkII

As the piston velocity increases further, the internal pressure rises. At a certain velocity the movement of the piston creates a pressure difference across the main piston that is equal to the predetermined pressure required to compress the spring (fig. 2.7-E and 2.11-E) and allow the shims to bend more. The preload of the spring and the shim stack will determine how much the shims will bend. The more the shims bend the greater are the cavities that allows the oil to flow through the valve.

Note!

Usually, the piston does not reach a velocity high enough to cause a sufficient pressure drop and open the shim valve totally.

3. TTX40/ TTX46 MT

The oil has now reached the low-pressure zone at the gas reservoir (fig. 2.3-F, 2.7-F and 2.11-F). This volume is in direct contact with the separating piston on the TTX40 and connected to the separating piston by a small hole on the TTX46MT. The separating piston separates the oil from the nitrogen gas. Here the pressure is always equal to the set gas pressure. As the TTX40/TTX46MT is a through rod damper, there will be no fluid displacement by the piston rod. However, a gas volume is still needed to reduce changes of the static internal pressure due to volume changes caused by temperature variations. The rising temperature of the damper will increase the volume of the oil. Also the damper body will expand as the temperature increases, but not to the same extent.

4. TTX40/ TTX46 MT

Now the oil will flow through the compression check valve (fig. 2.3-G, 2.6b-G, 2.7-G, 2.10b-G and 2.11-G) positioned at the rebound valves. However, as long as the low speed rebound bleed valve isn't fully closed, some oil will flow through this valve backwards (fig. 2.3-H, 2.6b-H, 2.7-H, 2.10b-H and 2.11-H).

👁 Note!

The compression check valve is placed together with the rebound valves.

5. TTX40/ TTX46 MT

From here the oil flows between the two tubes (fig. 2.3-I, 2.7-I and 2.11-I). The oil re-enters the main tube on the rebound side through ports placed between the end cap and the inner tube (fig. 2.3-J, 2.7-J and 2.11-J).

The compression flow circuit is completed.

Flow circuit at rebound cycle

Below is a description of how the oil flows from the rebound side to the compression side of the piston. The rebound cycle is very similar to the compression cycle, but the flow will be in the opposite direction and the oil will move through different valves. During the rebound stroke, the pressure of the rebound side of the main piston is increased, while the pressure of the compression side is kept almost constant.

1a. TTX40

First of all, the oil has to get to the rebound valves. The ports between the end cap and the inner tube (fig. 2.5-A and 2.9-A) will lead the oil to the volume between the tubes (fig. 2.5-B and 2.9-B) from where the oil will reach the chamber below the rebound valves (fig. 2.5-C and 2.9-C). The pressure here will be roughly the same as in the rebound side of the cylinder tube due to small restrictions of the oil flow. The pressure will help to close the check valve in this chamber.

1b. TTX46MT

First the oil has to get to the rebound valves. The ports between the upper seal head and the inner tube (fig. 2.13-A) will lead the oil to the volume between the tubes (fig. 2.13-B) from where the oil will reach the chamber below the rebound valves (fig. 2.13-C). The pressure here will be roughly the same as in the rebound side of the cylinder tube due to small restrictions of the oil flow. This pressure will help to close the check valve in this chamber.

2. TTX40/ TTX46 MT

See section 2. TTX40/ TTX46 MT under *Flow circuit at compression cycle* in this chapter for more detailed information as the rebound valves are identical to the compression valves.

2a. TTX40/ TTX46 MT

Unless the low speed rebound valve is fully closed, the oil will first pass through this valve (fig. 2.5-D, 2.8a-D, 2.9-D, 2.12a-D and 2.13-D).

2b.1 TTX40/ TTX46 MT Mkl

The second valve to open is normally the nose shim stack (fig. 2.4-E and 2.5-E).

2b.2 MklII

The second valve to open is the shim stack on the valve (fig. 2.8a-E, 2.9-E, 2.12a-E and 2.13-E). It starts with the largest shims, diameter more than 20 mm, starts to bend and in this way lets the oil flow through the valve.

2c.1 Mkl

If the pressure level reaches the opening pressure of the poppet valve, the poppet valve will open (fig. 2.4-F and 2.5-F).

2c.2 MklII

If the pressure level reaches the opening pressure of the spring valve, the spring will let the preload ring to lift and the shim stack will let more oil through the valve (fig. 2.9-F and 2.13-F).

3. Now the oil has reached the low-pressure zone at the gas reservoir (fig. 2.5-G, 2.9-G and 2.13-G), where the pressure is equal to the gas pressure.

4. The oil will now flow through the rebound check valve (fig. 2.5-H, 2.8b-H, 2.9-H, 2.12b-H and 2.13-H) positioned at the compression valves. Some oil can, in the same way as described above in *Flow circuit at compression cycle*, flow backwards through the low speed compression valve (fig. 2.5-I, 2.8b-I, 2.9-I, 2.12b-I and 2.13-I) unless it is set to the fully closed position.

👁 Note!

The compression check valve is located together with the rebound valves.

5. Finally the oil re-enters the main tube on the compression side through a port in the separating plate (fig. 2.5-J, 2.9-J and 2.13-J).

The rebound circuit is completed.

2 - General Description

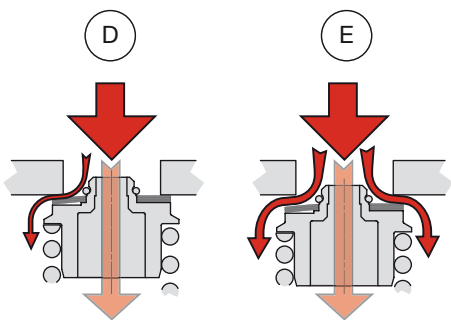
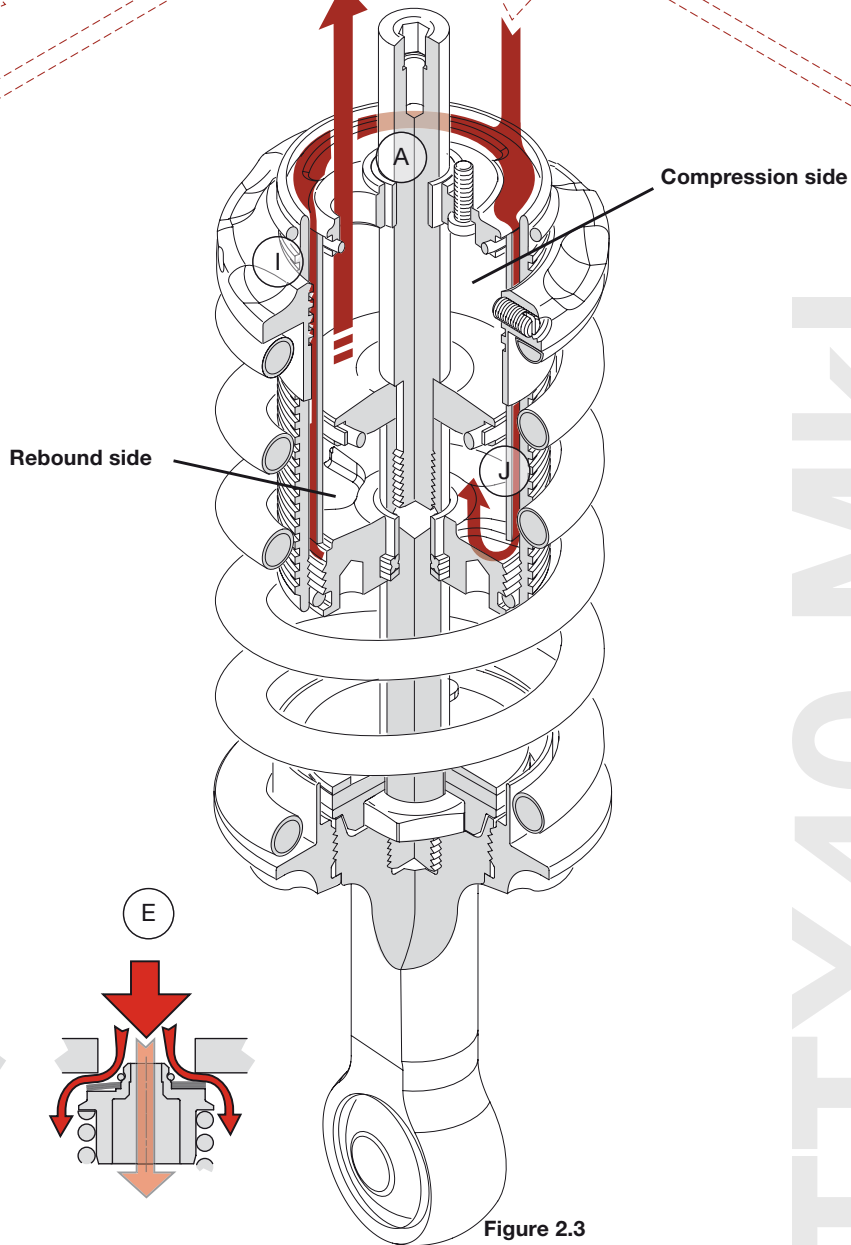
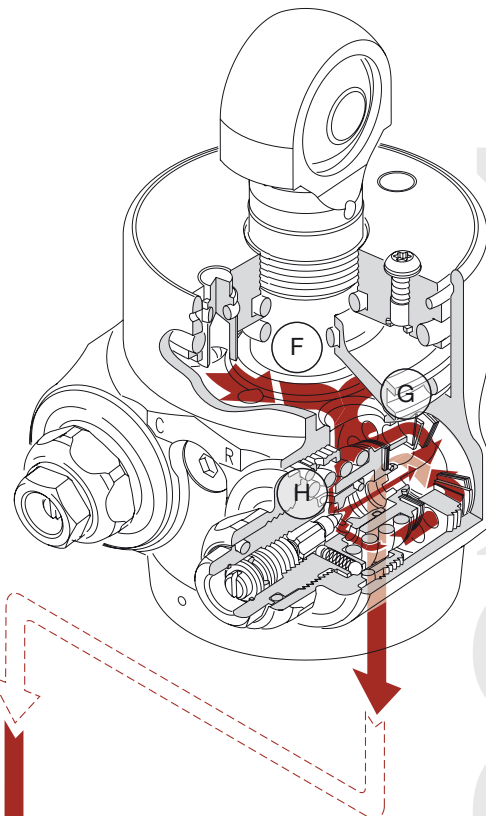
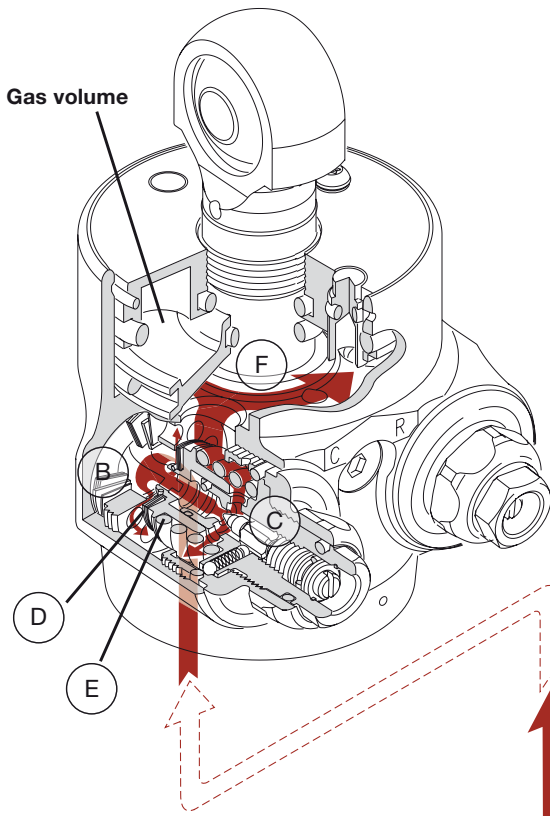

Figure 2.2
Poppet valve for compression TTX40 Mkl.

Figure 2.3
Flow circuit during compression cycle for TTX40 Mkl.

TTX40 Mkl
COMPRESSION

2 - General Description

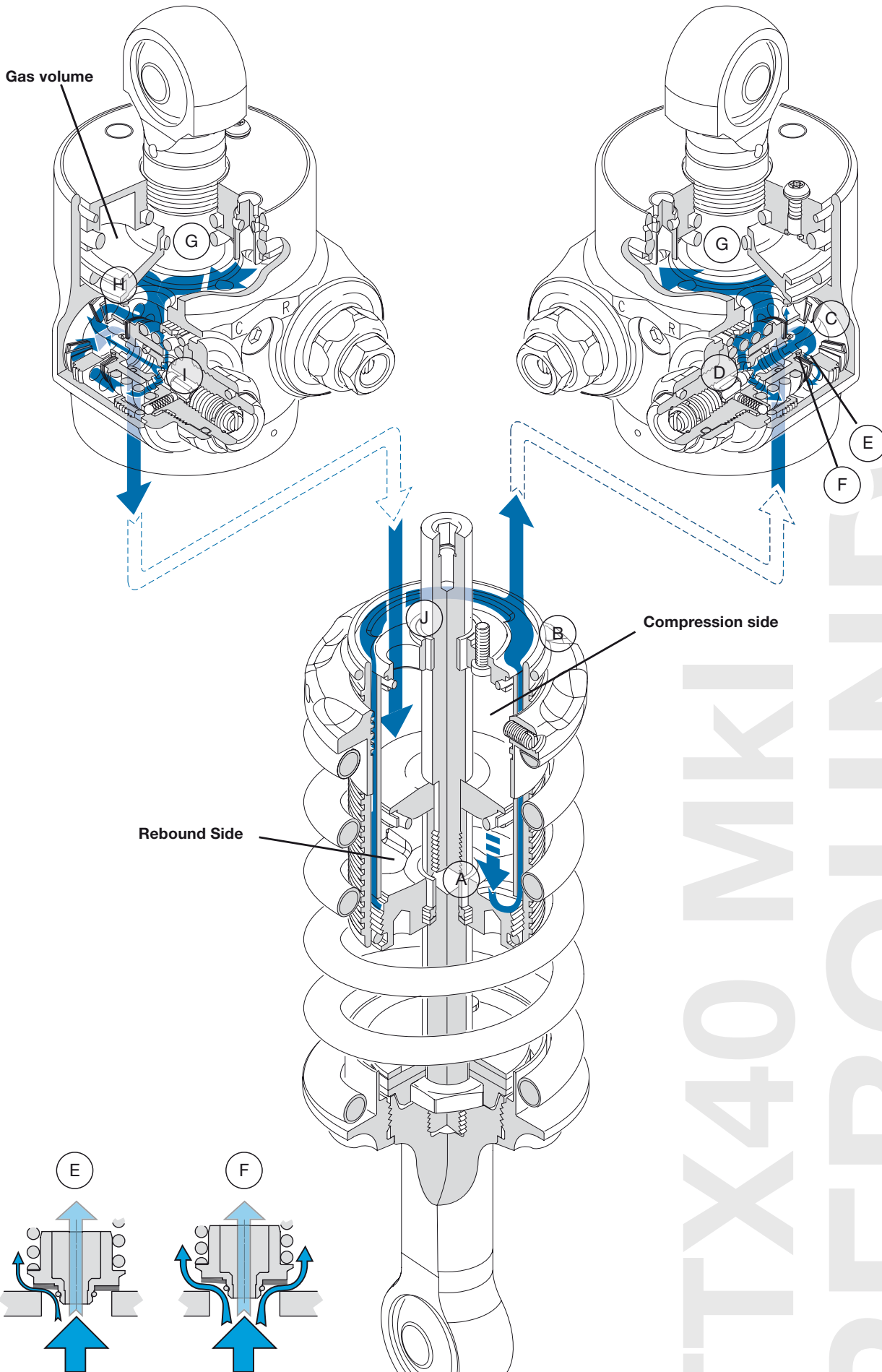

Figure 2.4
Poppet valve for rebound TTX40 Mkl.

Figure 2.5
Flow circuit during rebound cycle for TTX40 Mkl.

2 - General Description

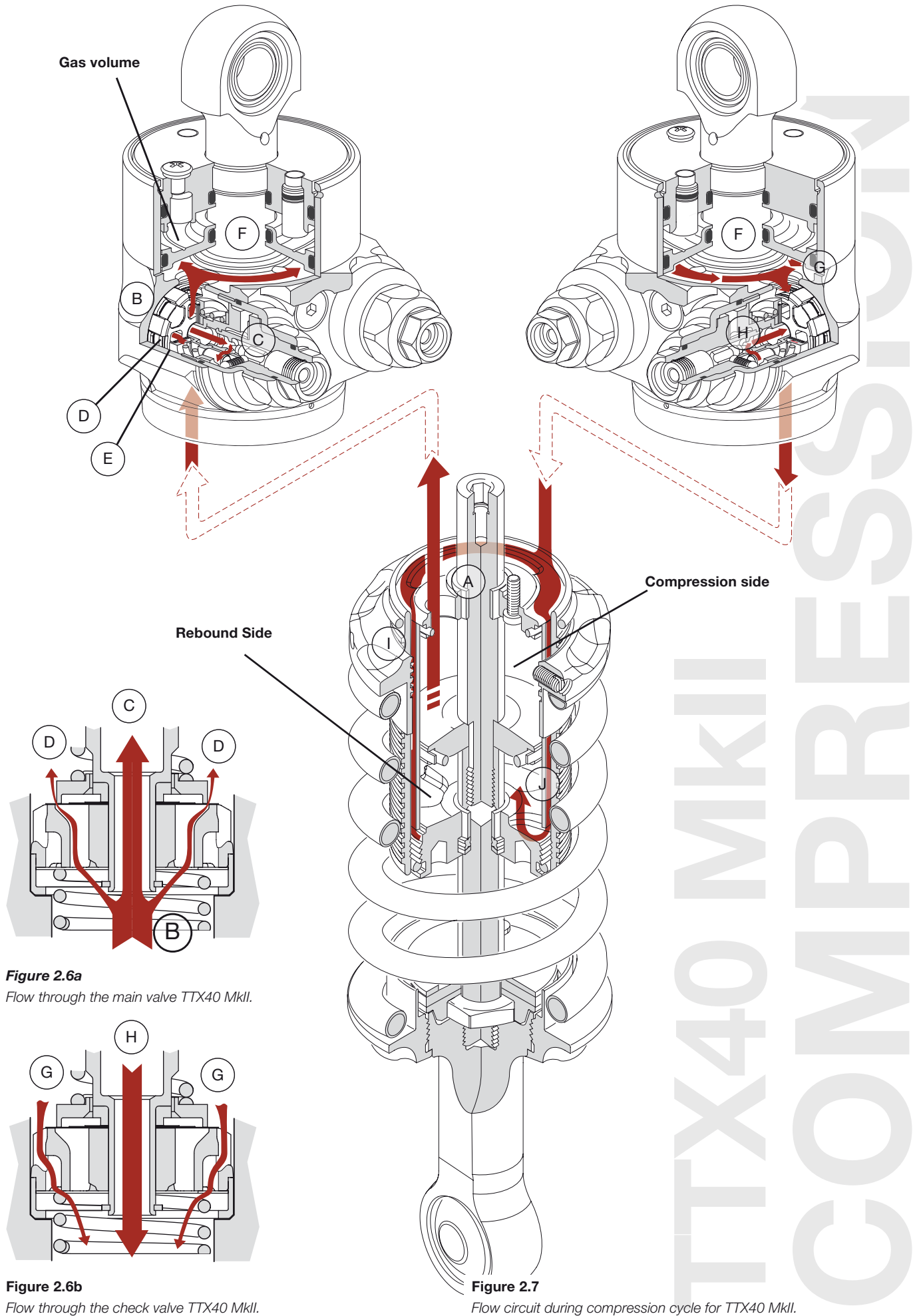

Figure 2.6a
Flow through the main valve TTX40 MkII.

Figure 2.6b
Flow through the check valve TTX40 MkII.

Figure 2.7
Flow circuit during compression cycle for TTX40 MkII.

2 - General Description

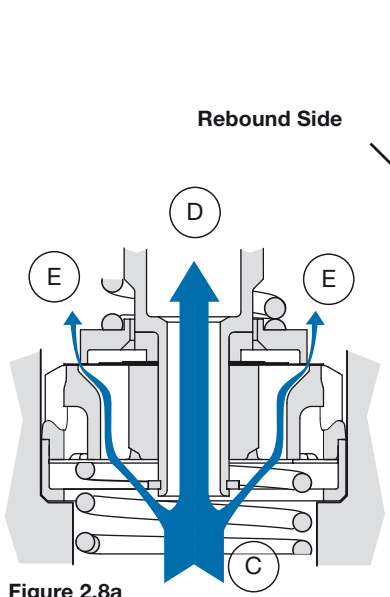
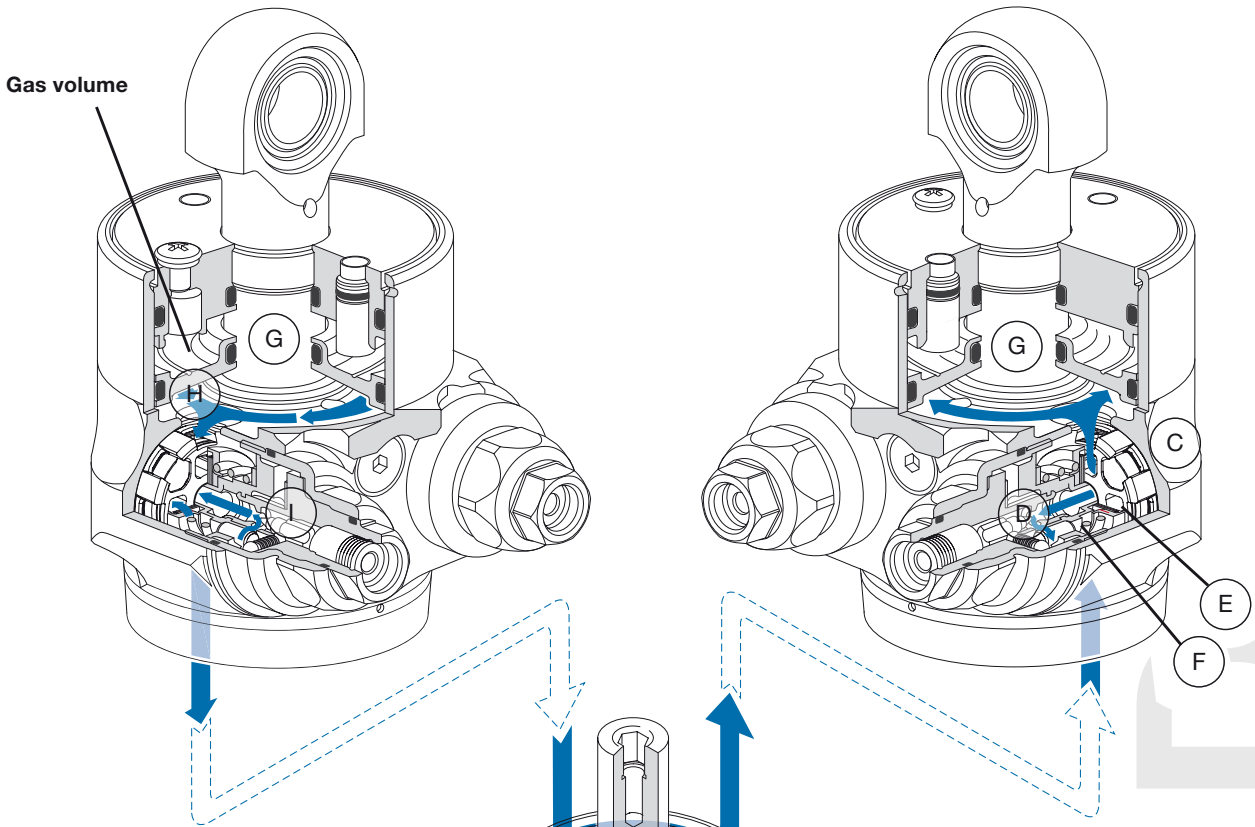

Figure 2.8a
Flow through the main valve TTX40 MkII.

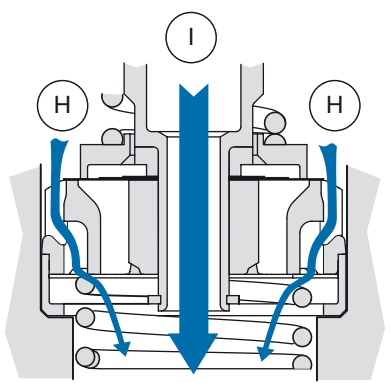

Figure 2.8b
Flow through the check valve TTX40 MkII.

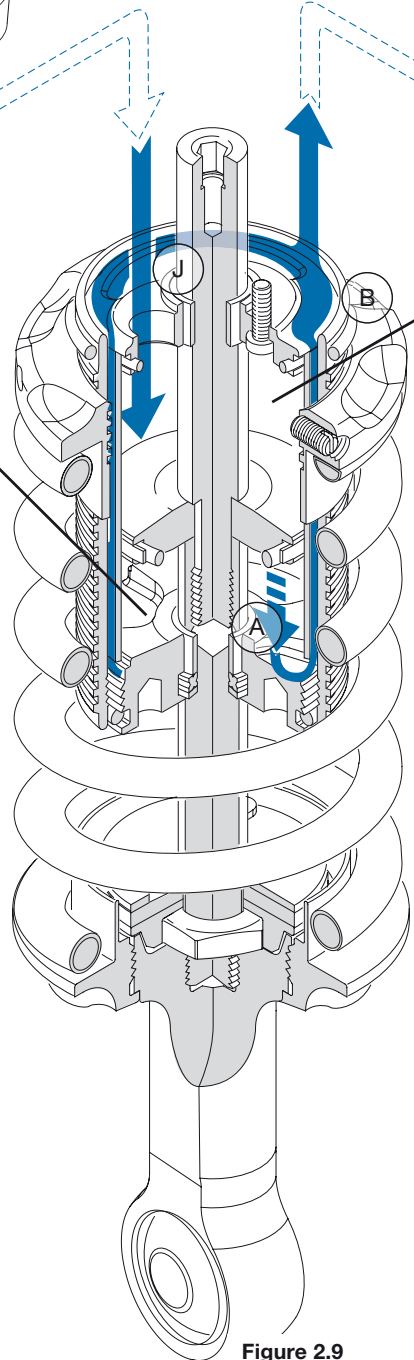

Figure 2.9
Flow circuit during rebound cycle for TTX40 MkII.

TTX40 MKII
REBOUND

2 - General Description

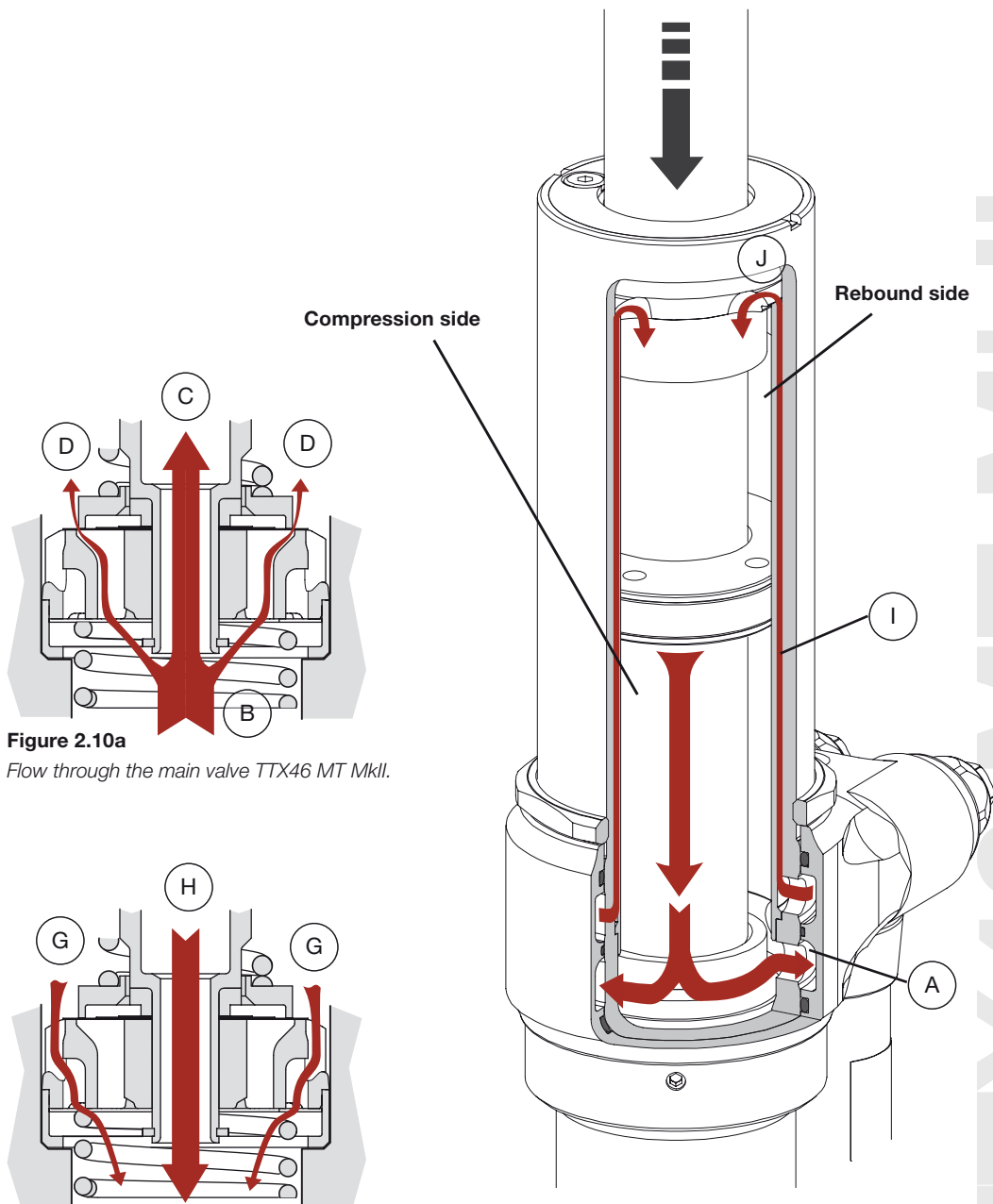
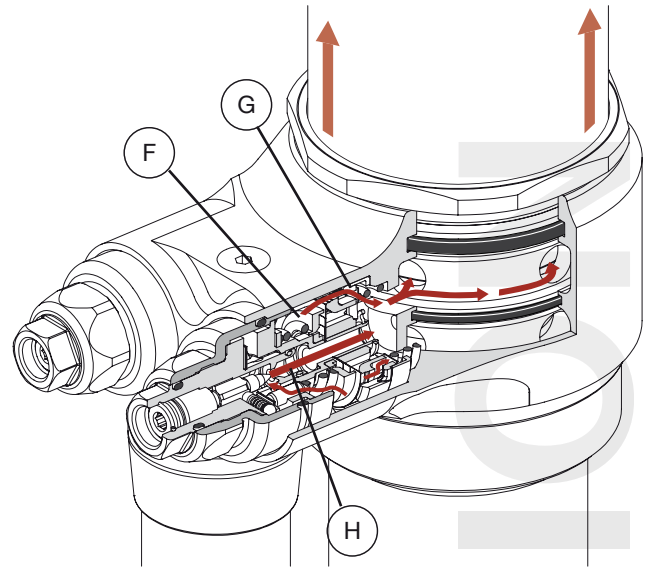
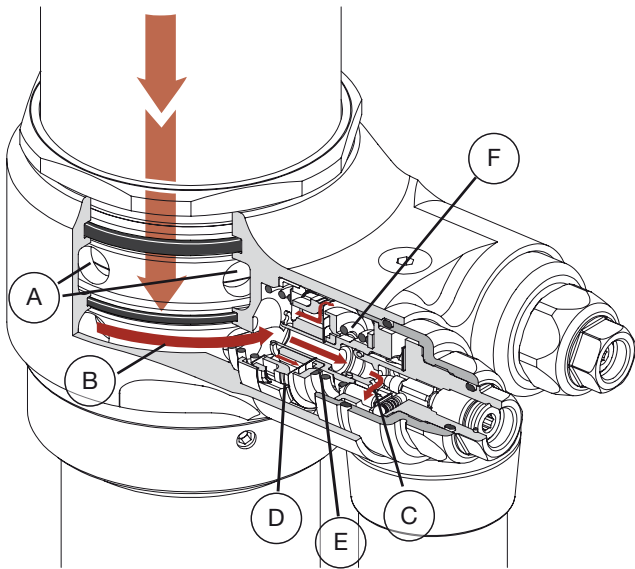

Figure 2.10a
Flow through the main valve TTX46 MT MkII.

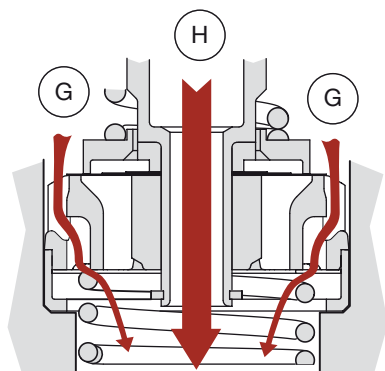

Figure 2.10b
Flow through the check valve TTX46 MT MkII.

Figure 2.11
Flow circuit during compression cycle for TTX46 MT MkII.

2 - General Description

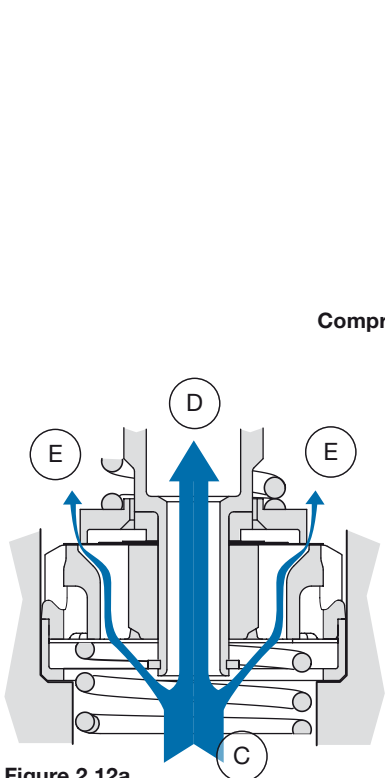
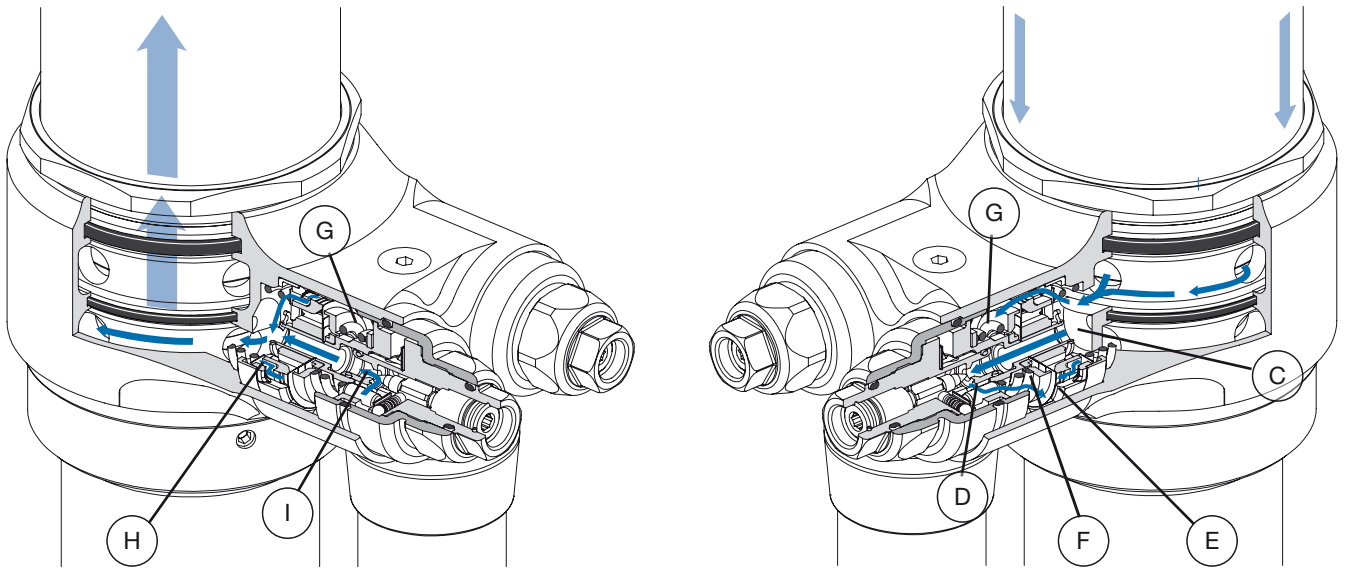

Figure 2.12a
Flow through the main valve TTX46 MT MkII.

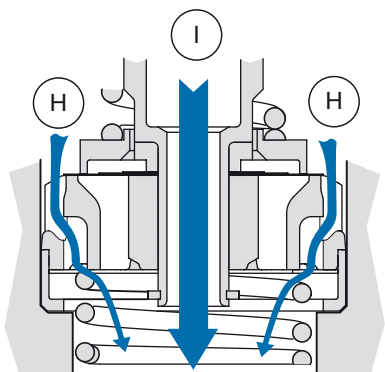

Figure 2.12b
Flow through the check valve TTX46 MT MkII.

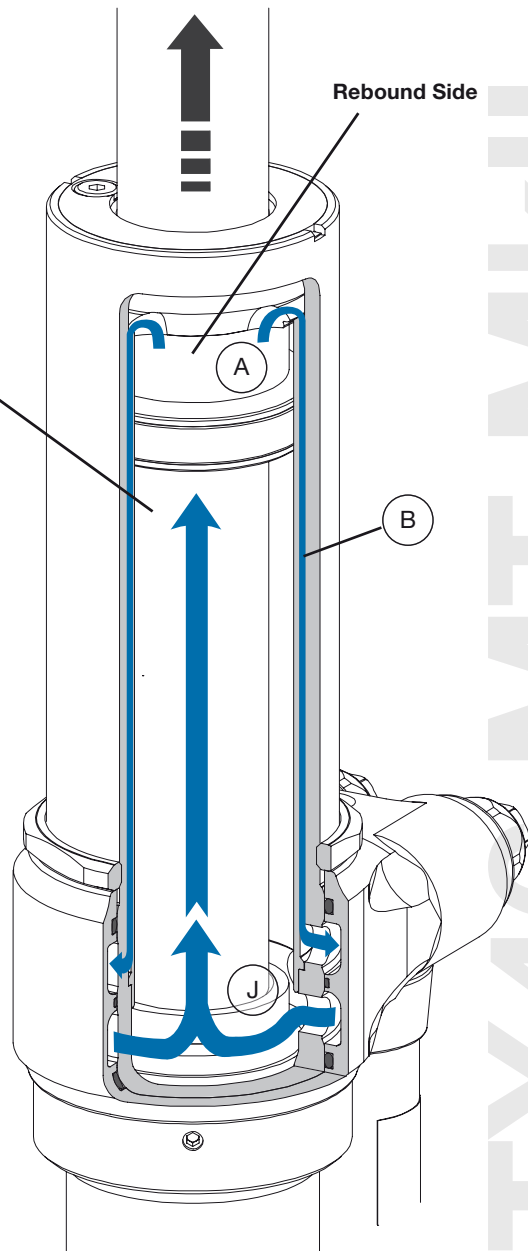

Figure 2.13
Flow circuit during rebound cycle for TTX46 MT MkII.

TTX46 MT MkII REBOUND

3 - Damping Force Measurement

Damping forces is a frequent subject of discussions at race weekends. It is important to understand that depending on how the damping forces are measured, the force values can turn out very differently.

Within a race team, where the values normally always come from the same source this is normally not a problem. A team mainly needs a damper dynamometer to ensure their dampers produce the damping forces that are expected. This means that no "heavy duty" dynamometer is needed. For formula racing applications and many other types of asphalt racing a dynamometer that can reach 5 inch/second (0.127 m/s) is enough. The type of dynamometers mainly used are of the "crank type". The price tag, size and simplicity are the main advantages of these machines. A crank dynamometer can be used for "continuous measurement" or "peak velocity measurement". A hydraulic dynamometer can be used for any type of measurement.

The requirements for a damper manufacturer, doing research and development, are very different and other types of machines are needed.

There is not one perfect way of measuring damping forces, as different situations ask for different needs.

See chapter *Damping curve terminology* for information about how to read damping graphs.

For a race team a continuous measurement of the damping force is very good: the measurement is quick, makes it very easy to tune the damping curve to a desired shape, hysteresis and cavitation is easy to detect and "dynamic problems" can be found. An example of a dynamic problem that can be detected this way is sticking check valves.

With continuous measurement of the damping force, the damper movement mimics a "sine wave", often in the region of 1.6 Hz. As both the acceleration and the deceleration part can be seen, there will be two force values for any given velocity except for the maximum velocity. Sometimes the terminology "dynamic testing" is used for this type of damper testing, including other types of movements than just sine wave movements, but with the common factor that the measurements are done during variations in velocity.

As can be seen in the figure, the acceleration force values are lower than the deceleration force values when passing zero velocity. This separation at low velocities is called "hysteresis". See chapter *Hysteresis* for more information. When "matching" dampers, the teams often pick half of the cycle to keep the overlay of curves from different dampers as clean as possible. It is common to use compression opening (measurement during acceleration) and rebound closing (measurement during deceleration).

Many times the result of continuous damping force measurement can be presented in a force-displacement graph. These types of curves are sometimes named "egg curves".

If continuous measurement is used, the forces given are dependent on the stroke and frequency being used. By changing the crank length and the frequency of the dynamometer machine so to maintain the same peak velocity, let say 5 inch/second, the damping force curves will change. From the formula below, you find that, for example, a reduction of the amplitude to half will give the same peak speed if the frequency is doubled.

$$v_{max} = A \cdot 2\pi \cdot f \quad [m/s]$$
$$v_{max} = \text{peak velocity} \quad [m/s]$$
$$A = \text{amplitude} \quad [m]$$
$$f = \text{frequency} \quad [Hz]$$

The less travel required to reach a specific velocity, the more pronounced the hysteresis will be in the graph. As hysteresis is found when the movement change direction, in other words at zero velocity, tests where different strokes have been used to produce the same peak velocity will differ at low velocities due to hysteresis. See chapter *Hysteresis* for more information.

3 - Damping Force Measurement

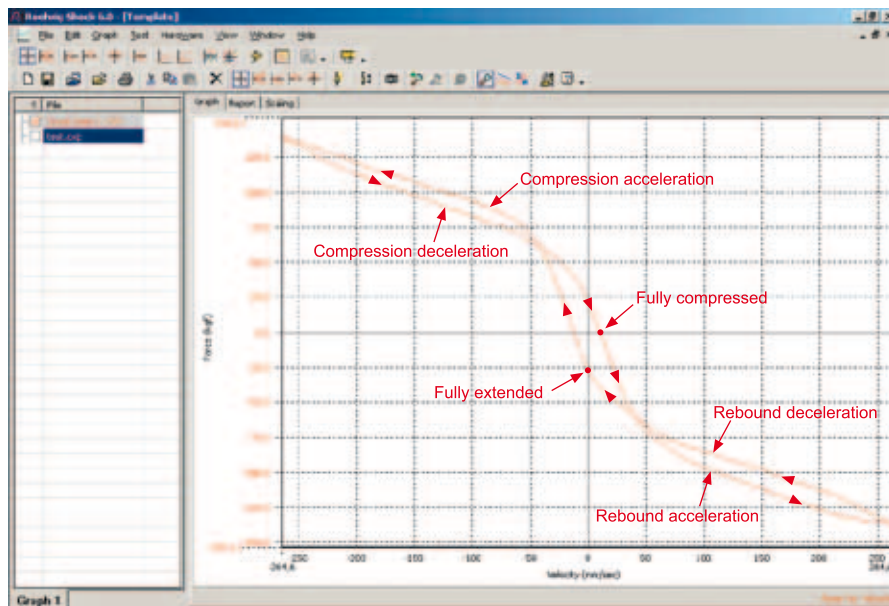

Figure 3.1

Damping force measured continuously in a Roehrig dynamometer. The bleeds are fully closed.

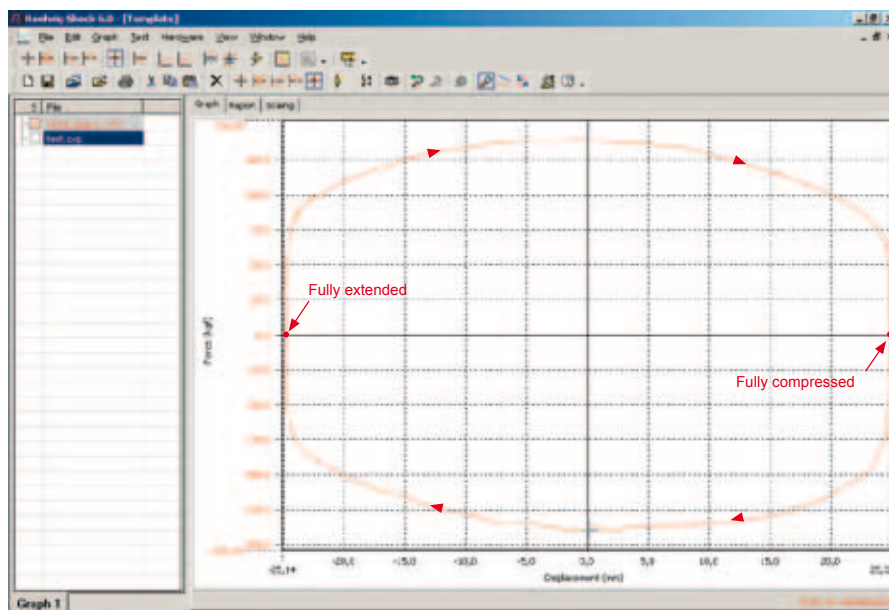

Figure 3.2

Damping force measured continuously in a Roehrig dynamometer. Here the result is presented in a force-displacement graph. The data comes from the same run as in the previous figure.

3 - Damping Force Measurement

Note!

Comparing the forces figures 3.2 with the force of 3.3, there is a huge difference in force at low speed. When the damping force is measured continuously the hysteresis give the impression that the bleeds are quite open and a small bleed change can be hard to notice in the graph.

Sometimes the software uses a filter to reduce the level of noise in the graphs. Some race teams do damping force measurement at constant velocity.

Sometimes the terminology “static testing” is used for this type of testing. For matching dampers this method is excellent. For a damper manufacturer, working with different race teams using different methods of measuring damping forces, measuring at a constant velocity is preferred. Otherwise as explained above, when using continuous measurement, there is always a risk that the values discussed comes from different methods of measuring. When the damping force is given at a constant velocity, there is only one value of the damping force at each specific velocity.

A crank dynamometer can't be used for constant velocity measurement, but by measuring the damping force at different peak velocities, the result is normally very close. When a crank dynamometer is used, the machine always produces sine wave movement. By changing the frequency of the dynamometer, different peak velocities are reached.

The number of runs varies depending on the needs. Of course small steps extend the test time. In a hydraulic dynamometer, the piston rod is accelerating to the desired velocity in a short distance, and the flow of oil through the valves in the damper is kept “static” during a large part of the stroke. This makes it possible to take hundreds of measurement before the dynamometer decelerates the piston rod.

Note!

In this manual, if there is no other information, all graphs illustrated come from Öhlins TTX VRP. The data used in the TTX VRP are produced by an Instron hydraulic dynamometer at Öhlins Laboratory. The forces are measured at constant velocity.

It is very important to know when dynamometer testing dampers if the forces measured are compensated for gas force or not. Most racing dampers (pressurised, and not through rod type) add a gas force to the damping force. The gas force should be seen as an extra spring force from a spring with very low rate. This force is position dependant (close to constant) and not velocity dependant and should therefore be removed when damping force is plotted.

An idea of the amount of gas force a damper produces at a specific piston position (normally small variations at piston positions) can be found by compressing the damper by hand and keeping it at a static position. The gas force will now try to push the piston rod out of the damper body.

Figure 5.3

Damping force measured at constant velocity. The lined curve is compression, the dotted curve is rebound. The setting is the same as in the two previous figures.

This force is calculated as

$$F_{rod} = p_{gas} \cdot A_{rod} \quad [N]$$

p_{gas} = gas pressure above atmosphere pressure (the value read on the pressure gauge when pressurizing the damper) [N/m², 1 bar=10⁵ N/m² = 15 psi]
 A_{rod} = piston rod area

For example, at 10 bar (15 psi) gas pressure in the TT44/40 (∅16 mm piston rod), the gas force is approximately 200 N (45 lbs). When you look at a dynamometer curve that has been gas force compensated, you are looking at the actual damping forces produced by the damper.

For non gas compensated dynamometer curves, the actual damping forces are calculated from the formulas below.
 Compression damping = measured compression force – Frod
 Rebound damping = measured rebound force + Frod
 The TTX damper has no resulting force from the gas pressure (Frod = 0), so it always gives the same forces no matter if the testing is gas compensated or not.

Note!

If matching the forces from a TTX damper with the forces from a conventional damper tested without gas compensation, the forces of the conventional damper has to be gas force compensated with the formulas above to get the same amount of damping.

Note!

Keep in mind that even if the method for measuring the damping forces is identical there can be some small variations in the result from different damper dynamometers, due to individual variations between the machines.

Note!

All damping curves will change with temperature, so always keep track of the temperature. See chapter Temperature stability for more information.

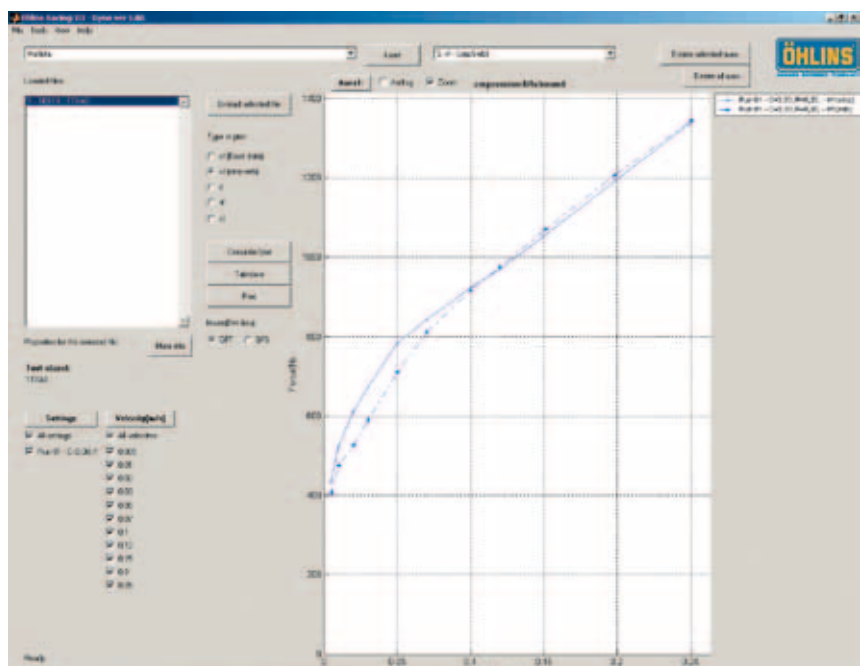

4 - Damping Curve Terminology

In order to understand the next part of this manual we must all speak the same language. In the damper industry there are terms used to help describe different parts of a dynamometer graph. The three key words are nose (low speed), knee and slope (high speed). Careful study of this section will yield a complete understanding of these terms and allow you to read damper curves. The horizontal axis in the figure gives damper velocity and the vertical axis shows damping force.

👁️ Note!

The velocity of the damper refers to the velocity of the piston rod movements, not to the speed of the car. Most of the piston rod movements on a race car reach only low velocities and the percentage number of strokes going through all zones described below is low.

Take a look at the figure above and notice the first portion of the damping curves – starting at 0 inch/second and ending at about 0.4 inch/second on the compression curve and about 2.7 inch/second on the rebound curve. This part of the curve is called the nose and is also referred to as low speed. The valve affecting this part of the curve is the low speed adjuster. It is always of a fixed orifice type (the size of the orifice is not variable by pressure, but by clicker adjustments) and is often called bleed. The design and size of the bleed determines the characteristics and shape of the nose.

The finish of the nose zone coincides with the beginning of the knee zone. Its location in the curve can be found by identifying where the upwards curve first begins to level off into a radius. Locating where the knee radius stops and blends into the straight line identifies the end of the knee zone and the beginning of the slope zone.

The shape of the knee is determined by the opening characteristic, gradual or abrupt. The more abrupt the opening phase is, the sharper the knee will be. The converse is also true. Normally the shape of the curve in the knee zone comes from the transition of the shims bending and when the force is big enough to start compress the high speed spring. At 1.2 inch/second the valve has totally gone from the shims bending to the spring opening. Due to the more open bleed on the rebound. The knees are not so pronounced.

👁️ Note!

Wide open bleeds in combination with a stiff shim stack and a lot of preload can allow the low speed zone to extend into relatively high velocities.

The shim stack and the preload of the coil spring normally determine the slope, also referred to as high speed. In most cases the slope will continue to rise in a straight line to damper speeds well beyond those found in most racing dynamometer charts. Eventually the slope will increase at an exponential rate. This happens when the size of the channels transporting the oil begin to restrict the oil flow (channels are also fixed orifices). The slope angle relative to the horizontal plane defines the magnitude of the slope and can be quantified as Pound/(Inch/Sec.) or N/(m/s). The nose, knee and slope are key words to understanding the following concepts.

Figure 4.1
Terminology

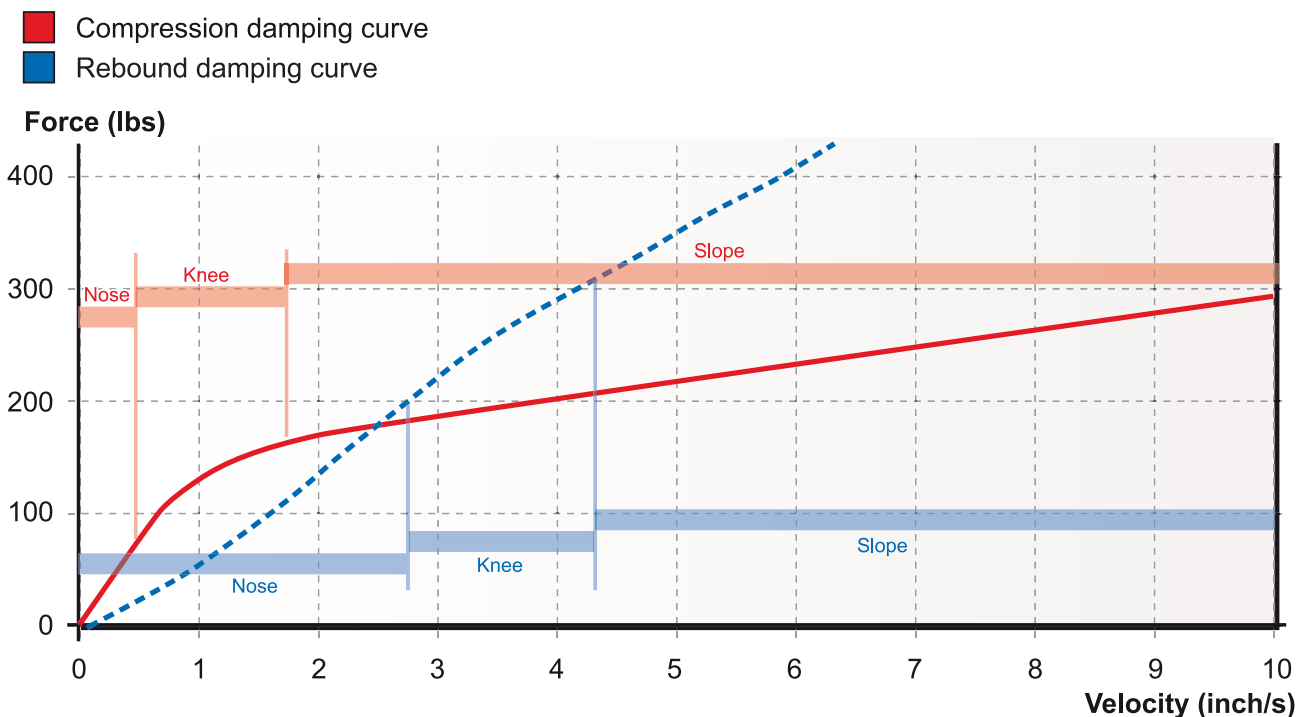

5 - External Adjusters

General description

Most dampers that are external adjustable have some type of low speed adjuster. Low speed adjusters are almost always externally adjustable orifices that become fixed after adjustment. Fixed in the sense that the orifice area is not dependent on the pressure drop over the orifice.

In the damper industry, these adjustable orifices are often referred to as bleeds or low speed adjusters. Unlike shim stacks, bleed orifices do not change size in response to changes in pressure. Because oil will always travel the path of least resistance, it will first flow through the open bleeds until there is enough pressure to open any other valves. Oil flows through the bleeds any time the piston rod is moving, and continues to flow in parallel with the flow through the piston shim stack after the stack has opened.

The most common type of external high speed adjuster is an adjuster that moves the knee up or down without changing the slope, or just marginally changing it. To achieve this, the amount of force pushing the valve, shim or poppet valve, against its seat is varied. That is done by changing the preload of the spring element, shim stack, coil spring, cup spring etc.

The oil flow that is controlled by the external adjusters varies between different type of dampers. The larger the flow is, the better the conditions will be for a powerful adjuster. There are two reasons for that.

- A larger flow is easier to control. The tolerances for the dimensions on the valve parts have to be tightened if the flow is reduced.
- A larger pressure area, the pressure area is proportional to the oil flow, will keep the internal pressure of the damper at a lower level. This increases the damper response and the damper will build up damping force quicker.

External adjusters summarised

The TTX40/TTX46MT damper from Öhlins comes as a 4-way externally adjustable damper. As some racing classes have rules about the maximum number of external adjusters there is a possibility to change the valves to a valve that is only one way adjustable.

By changing just one valve you can make the damper 3-way adjustable and by changing both valves you can make it 2-way adjustable. This valve has the high speed adjuster lock or only a low speed (bleed) adjuster. To adjust the high speed in this valve you need to take the valve out of the damper and re-shim it. The text below describes the valves that the dampers are delivered with.



Figure 5.1

External adjusters



Low Speed Compression Damping Adjuster (LSC)

Type of adjuster: Bleed adjuster
 Effects: The flow from the main piston during a compression stroke only.
 Pressure area*: TTX40: 1143 mm² (Ø40-Ø12) (12 mm shaft)
 TTX40: 1103 mm² (Ø40-Ø14) (14 mm shaft)
 TTX46MT: 955 mm² (Ø46-Ø30)
 Identification: The black screw with an internal 3 mm hex inside the gold
 12 mm hex at the cylinder head.
 Number of positions: 40
 Click position 0: Fully clockwise at maximum force (orifice closed).



Low Speed Rebound Damping Adjuster (LSR)

Type of adjuster: Bleed adjuster
 Effects: The flow from the main piston during a rebound stroke only.
 Pressure area*: TTX40: 1143 mm² (Ø40-Ø12) (12 mm shaft)
 TTX40: 1103 mm² (Ø40-Ø14) (14 mm shaft)
 TTX46MT: 955 mm² (Ø46 - Ø30)
 Identification: The black screw with an internal 3 mm hex inside the silver
 12 mm hex at the cylinder head.
 Number of positions: 40
 Click position 0: Fully clockwise at maximum force (orifice closed).



High Speed Compression Adjuster (HSC)

Type of adjuster: Spring preloaded shim stack or spring pre-loaded shimed poppet valve.
 Effects: The flow from the main piston during a compression stroke only.
 Pressure area*: TTX40: 1143 mm² (Ø40-Ø12) (12 mm shaft)
 TTX40: 1103 mm² (Ø40-Ø14) (14 mm shaft)
 TTX46MT: 955 mm² (Ø46 - Ø30)
 Identification: The golden 12 mm hex at the cylinder head/valve housing.
 Number of positions: Approx 50
 Click position 0: Fully clockwise at maximum force (spring max preloaded).



High Speed Rebound Adjuster (HSR)

Type of adjuster: Spring preloaded shim stack or spring pre-loaded shimed poppet valve.
 Effects: The flow from the main piston during a rebound stroke only.
 Pressure area*: TTX40: 1143 mm² (Ø40-Ø12) (12 mm shaft)
 TTX40: 1103 mm² (Ø40-Ø14) (14 mm shaft)
 TTX46MT: 955 mm² (Ø46 - Ø30)
 Identification: The silver 12 mm hex at the cylinder head.
 Number of positions: Approx 50
 Click position 0: Fully clockwise at maximum force (spring max preloaded).

* As it is a through rod damper, the compression and rebound pressure areas are the same. The pressure area multiplied with the piston velocity give you the flow (volume per time unit) of oil that passes through the valves.

5 - External Adjusters

As can be seen in the figure, the cylinder head on the TTX40 is marked "C" and "R" together with "+" and "-". This will help the first time users to separate Compression from Rebound and tells what direction the adjusters should be turned to increase (+) or reduce (-) damping. On the TTX46MT there is no "C" and "R" or "+" and "-". This is due to that the valve housing is a symmetrical part and we would like to keep the possibility to turn the valve housing around which gives the possibility to have the reservoir pointing upward.

Note!

All external adjusters are "fully hard" when turned clockwise until they stop. The clicker positions, including the high speed adjusters, is always counted from "fully hard". Never over tighten the adjuster since this can damage the valve.

The reason that "full hard" is used, is that it always is an absolute position. "Fully soft" will vary more depending on the tolerances, so the matching wouldn't be as good if the clicker positions were counted from full soft. The first click and/or detent is counted as "zero" position.

To match damping curves of a pair of dampers in the dynamometer, sometimes the clicker numbers will end up a couple of clicks from each other. Often they match within $\pm 1-2$ clicks, but sometimes you can see ± 3 clicks. Just remember maximum clockwise is "full hard" for all adjusters and the adjusters are counted from full hard.

Low speed adjusters

The TTX40/TTX46MT features two fully independent low speed adjusters adjusting the main piston oil flow. For a specific damping force, the internal pressures can be kept low, giving a minimum of delay in the damping force build up. The two low speed adjusters (bleeds) LSC and LSR are identical and are designed so that in the normal operating range each click of the adjusters will change the damping in close to equal steps. They are tapered needles working in fixed orifices, but due to a double coned nose of the needle, the damping force doesn't increase progressively per click as the needle is closed. The adjusters are powerful over the whole range making it easier to find the optimum settings. Both adjusters have a range of approximately 40 clicks. Normally they match within ± 2 clicks. The bleeds are adjusted with a 3 mm Allen key. Do not use too much torque when closing the bleeds completely. Generally it is better to start with the adjusters a little more open and gradually close them off. See chapter Damping guidelines for more information.

Figure 5.2

Influence of the low speed adjusters. The graph represents both the LSC and the LSR.

Low speed adjusters effect on damping curve

Assuming the LSC and the LSR have the same clicker setting, the piston velocity is the same and that there is no oil flowing through the high speed, exactly the same amount of oil will flow through both valves. The LSR has exactly the same affect on the nose of the rebound damping curve (see chapter Damping Curve Terminology for more info) as the LSC has on the nose of the compression damping curve.

The different curves in figure 5.2 are achieved by adjusting only the LSC/LSR. The numbers above the curves represent low speed adjuster clicker settings. The dotted curves pointing upwards indicate the theoretical shape of the curves if there was only a low speed valve and no high speed valve to open. The valve used here is for information use only.

For real values for the VRP (Valving Reference Program) - see www.ohlins.com. If the adjuster is turned counter clockwise the clicker numbers get higher. As the bleed is opened more and more, the damping is reduced and the speed at which the knee starts increases and the nose is stretched longer and longer. Also, the force of the knee and the slope angle will remain the same. This is because only the high speed valve determines the knee height and the slope.

This means that even the high speed damping will drop as the low speed adjuster is opened. The more slope there is, the more the high speed will drop.

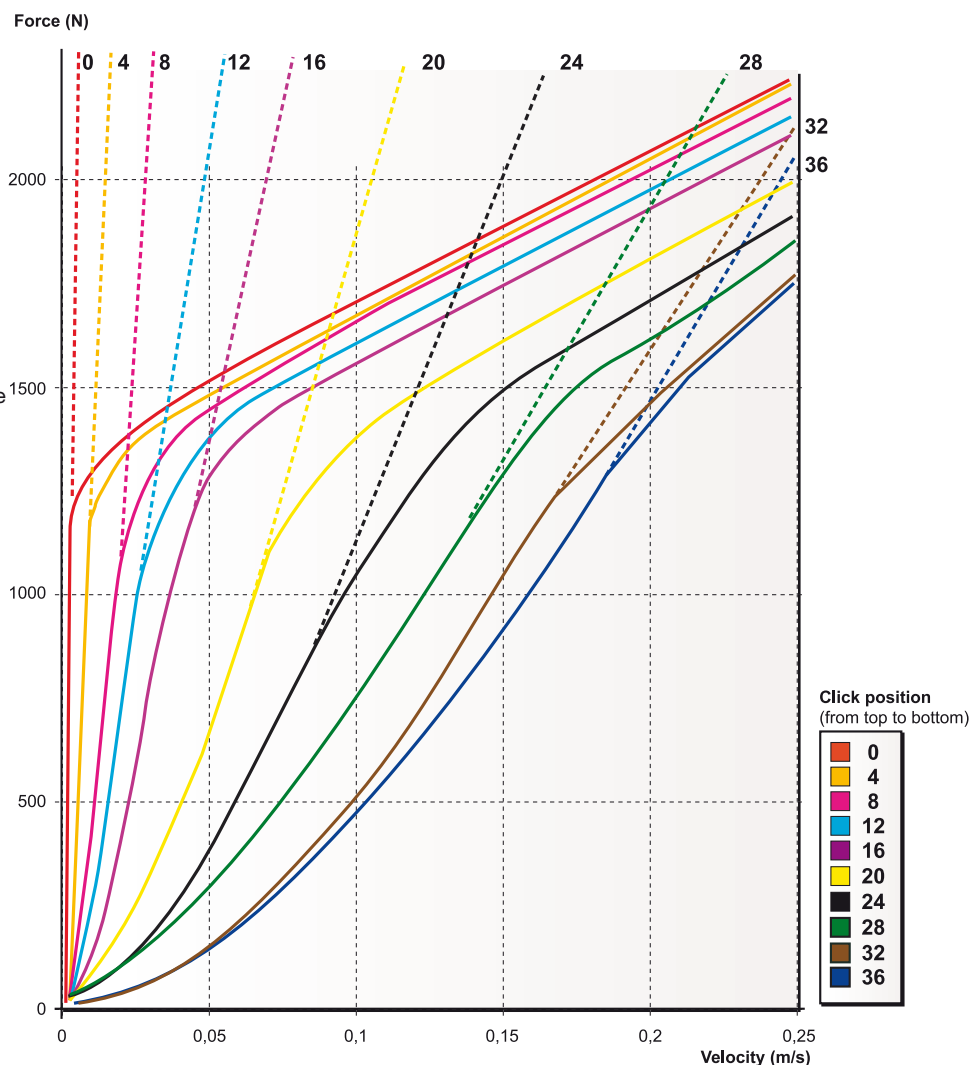

Conversely, if you wish to keep the knee force constant, the spring (high speed) preload has to be increased every time the low speed adjuster is opened. If the low speed adjuster instead is turned clockwise, the opposite from above will be true.

High speed adjusters

The TTX40/46MT has two high speed adjusters; one for compression and one for rebound. A damper like the TTX 40/46MT is often called fully adjustable. This provides race engineers and technicians with more external control over the damping. Anything that can make an adjustment quicker and thereby gain time during practice and qualifying is important.

Just as the low speed adjusters, the high speed adjusters HSC and HSR are identical (only the colour of the needle housing is different, gold for compression and silver (clear) for rebound, fully independent and adjust the main piston flow. They are delivered with the same valving, except the model specific dampers like the BMF or POF kits.

Both high speed adjusters on the MkI consist of a poppet valve preloaded by a coil spring. The coil spring pushes the poppet against its seat. On the MkII the both high speed adjusters consist of spring preloaded shim stacks. The preload of the spring determines the pressure differential needed to make the valve open. The adjusters change the amount of preload. A preload change will change the height of the knee. Each click of the adjusters changes the damping in almost equal steps.

Both valve types work the same way. Both are pressure regulators that control the oil flow by opening at a pre-determined pressure and thereby providing a path for the oil to flow. In the nose of the poppet valves, on the MkI dampers, shims make it possible to adjust the sharpness of the knee. There are alternative poppet valves with corresponding valve seats. There are also other springs available. See the MkI VRP and the Spare Parts List for more information about the parts.

Alternative parts for the MkII Valve can be found in the MkII Spare Part List or in the MkII VRP. Both the high speed compression and rebound adjusters have a range of approximately 50 clicks. Normally they match within ± 2 clicks.

The preload is adjusted with a 12 mm wrench.

👁 Note!

It is no problem to run the high speed adjusters at clicker position 0, as it is the needle housing that bottoms and not the spring that is coil binding.

High speed adjusters effect on damping curve

If the high speed compression and rebound valves have identical hardware and the adjusters are set the same, the damping forces will turn out the same.

The height of the knee is changed and the steps are about the same over the whole adjustment range. The low speed isn't affected at all and the slope remains unchanged.

To change the slope, the hardware has to be changed. As mentioned before, there are alternative parts for the valves. For information about the alternative hardware, see the Spare Parts List or the VRP program.

Shaping the high speed

The height of the knee depends on the stiffness and preload of the spring together with the pressure area of the poppet (MkI) or the shim stack (MkII). If the area is small (MkI) or the shim stack thick (MkII) it takes a higher pressure to overcome the force that is acting on the poppet (MkI) or the shim stack (MkII). The spring rate and the pressure area also controlling the slope of the graph by restricting the maximum size of the fluid path past the poppet (MkI) or shimmed valve (MkII).

👁 Note!

The spring rate is not a very powerful tool when it comes to changing the slope. For example if the spring rate is increased by a factor 10, the slope will only rise about 60%, but the adjustment range is increased about ten times.

6 - Limits in Force and Velocity

The TTX40/TTX46 MT is designed for pretty low damper velocities. It is hard to give a definitive limit in velocity, but peak velocities from 1 to 1.5 m/s (40 to 60 inch/s) are no problem.

When it comes to the limit in damping force, it is important to know that the peak forces are not normally the problem, fatigue is. Be aware that increased temperature reduces the strength of the materials. Peak loads at 90°C (250°F) reaching 8000 N (1800 lbs.) can be handled by the TTX40/TTX46 MT with no problem.

7 - Matching Damping Force

Even with tight tolerances, the types of high speed valves used in the TTX40/TTX46 MT are hard to get to match compared to main piston shim stack valves. This is the drawback of this type of valves. The adjusters can on the other hand be made extremely powerful and if a dynamometer is available, the graphs can be spot on if the adjusters are changed a few clicks.

Dampers set at the same clicker positions should match within $\pm 10\%$, but many times they match within $\pm 5\%$. All TTX40/TTX46 MT dampers are dynamometer tested at Öhlins Racing before they are delivered.

Start by studying chapter Damping force measurement.

Among teams, the experience of hysteresis mainly comes from continuous measurement of damping force during sine wave runs in a dynamometer. On those damper graphs, there is always a difference in ascending (acceleration) and descending (deceleration) parts of the curve around zero velocity. We normally refer to this area as hysteresis. At constant velocity or peak force measurements, the hysteresis can't be detected. Technically, the term hysteresis is related to energy losses, but here we are actually storing energy as the damper acts like a spring.

Hysteresis is actually flex in the damper system. The flex delays pressure rise and pressure drop. Hysteresis affects the performance of the damper. Generally, a minimum of flex is desired. Especially where there are very short damper movements. For example in single seaters, with very short strokes, you are dependent on quick damping force build up and if there is any delay, the damper might change direction before there is any damping at all. Because of this, hysteresis needs to be kept to a minimum.

How much the delay affects the damping curve is very much related to the stroke and frequency in the test. When keeping the maximum velocity constant and varying the frequency and stroke, it is very obvious that with a short stroke and a high frequency the hysteresis deforms the damping curve more than long stroke and low frequency.

In the graph (figure 8.2), the relation between displacement and velocity is shown for a peak velocity of 5 ips (0.127 m/s) and a frequency of 2 Hz.

Note!

The displacement at lower velocities is very small. Because of this, still with very little flex in the damper, the hysteresis in a dynamometer graph can easily be seen.

In a graph illustrating damping forces, the hysteresis changes the damping curve in a similar way as a more open bleed would do – both delay the damping force build up when using a sine input. The force drop from a more open bleed depends on the actual velocity, while the force drop due to increased hysteresis depends on the stroke. The setting and the hysteresis affect each other. The hysteresis increases at increased damping.

If only the compression acceleration and the rebound deceleration are illustrated, you don't see the amount of hysteresis. Therefore, it is easy to believe the bleed is more open when it actually is due to the hysteresis. There have been situations when teams have used the dampers with a low speed adjuster set to almost fully closed position. As the damping curve nose at continuously measurement still doesn't go vertical, the teams have asked for a different adjustment range of the low speed adjusters to put the actual clicker setting more in the middle of the range. Here, they have been misled by the hysteresis.

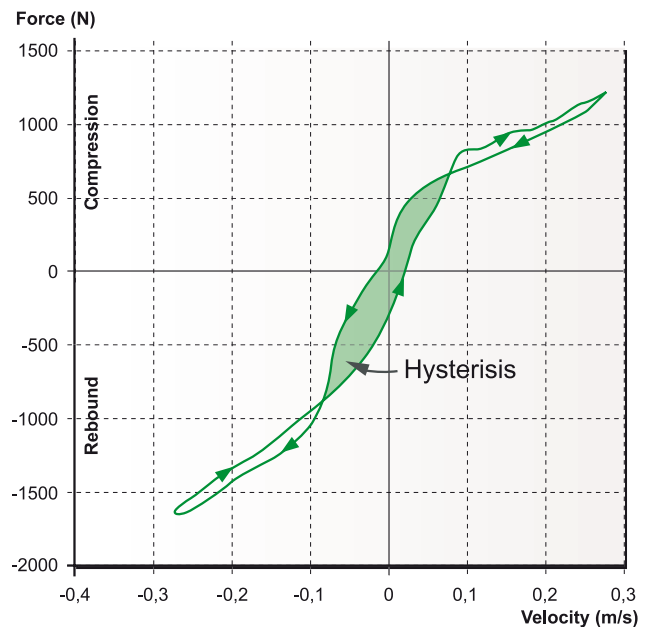

Figure 8.1

Damping force during a complete sine-wave cycle illustrating hysteresis. Due to the low hysteresis of the TTX40/ TTX46 MT, some oil has been replaced with air to get a better illustration of hysteresis.

8 - Hysteresis

Due to the low amount of hysteresis of the TTX40/TTX46 MT compared to other dampers, this should be less of a problem. Damper flex can be classified into three different groups: flex of damper parts, flex due to damper oil compressibility, and flex of gas present in the oil (dissolved or bubbles). The flex of the damper parts is fully elastic and linear. The compressibility of the oil itself is not linear. Some hysteresis comes from the compression and expansion of gases in the oil. Gas bubbles in the oil will be compressed in a very progressive way and will act almost like a slack in the system. Dissolved gas in the oil is a result of different factors. Air enters the damper during the filling procedure and some air is already dissolved in the oil when it is delivered. By using a vacuum filling machine, the amount of air in the oil can be minimised. With a vacuum machine there is no risk of trapping air in the damper.

The oil used for filling the damper has been under low pressure for some time before it enters the damper. This removes air dissolved in the oil. But even without air, there will be gas bubbles at low pressures. Oil contains different additives that boil at different pressures/temperatures. At low pressure, those additives change to a gaseous form which creates bubbles. See chapter "Cavitation" for more information.

The amount of hysteresis for a certain damping force can be very different depending on the size of the piston (pressure area) and the volume of oil that is pressurised. The larger the piston is, the easier it will be to reduce the hysteresis. This is explained by the formula $F = p \cdot A$. F is the force, p is the pressure and A is the pressurised area. For a specified damping force (F) a smaller area (A) will lead to a higher pressure (p). The higher pressure will make the damper flex more. This will cause more hysteresis.

On conventional dampers where the gas reservoir is connected to the compression side, (not on the TTX40/TTX46 MT), the piston rod acts as a small diameter piston sending oil to the valve in the reservoir. Because the effective pressure area is very small and the total oil volume is large, there will be a lot of hysteresis from this portion of the damping force compared to the damping force produced by the main piston.

On all dampers where the internal pressure of the damper pushes the piston rod out of the damper body, a "hysteresis effect" might be seen on the dynamometer graph. This is not the case with the TTX40/TTX46 MT. How much of this "hysteresis effect" that will be seen depends on how well the dynamometer compensates for the gas force. The reason for this is that on a conventional damper the static piston rod force varies depending on the position of the piston rod.

The more compressed the damper is, the higher the internal pressure will become due to the gas volume being compressed. For example, if the gas force compensation only reduces the compression damping and increases the rebound damping with the static piston rod force measured when the damper is at maximum length in the dynamometer, the compensation will not be enough when the damper is more compressed. This difference can be mistaken for hysteresis. Good gas force compensation will avoid this problem.

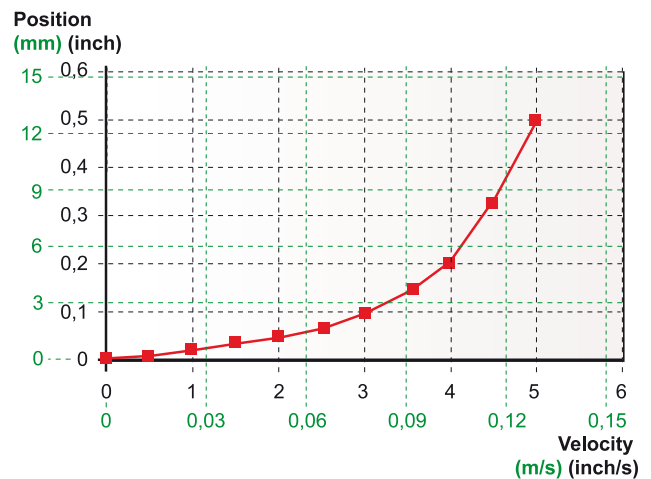

Figure 8.2

Stroke-velocity relation in a typical dynamometer run. Peak velocity 5 ips (0.127 m/s) and frequency 2 Hz.

Cavitation is a word used a lot in the pump and damper industry for describing the phenomenon when gas bubbles are produced in fluids at pressure drops. The gas comes from both the fluid that has changed its state from fluid to gas and from air that had been dissolved in the fluid. Cavitation also includes the collapse of the gas bubbles when the pressure increases and the gas returns to liquid form.

In conventional dampers, cavitation very often occurs on the rebound side of the piston. If no reservoir valve is used the damping force mainly comes from a pressure drop on the rebound side. Here the set gas pressure has to be high enough to allow a pressure drop on the rebound side without letting it get too low. By using a reservoir valve the pressure doesn't have to drop as much on the rebound side as there also will be some increased pressure on the compression side due to the reservoir valve. However, if the piston rod is extended near full rebound, the volume on the rebound side will be small and the pressure will drop very quickly, so some cavitation will still occur.

Cavitation in dampers should always be prevented. Cavitation can cause serious malfunction, reduced performance and damage the damper.

Absolute pressure, temperature and type of fluid are factors that affect the risk of cavitation. Normally, an absolute pressure drop below 0.7-0.8 bar (10-12 psi) cause cavitation. For your information: The absolute pressure in the atmosphere is close to 1 bar (15 psi) at sea level altitude. High piston accelerations will increase the risk of cavitation as pressure changes do not immediately effect the entire volume of oil due to delays in the pressure distribution in the fluid. These different pressures in the same volume of oil are sometimes called "dynamic pressures".

As cavitation is a state change from fluid to gas, compare boiling of water, an increased temperature increases the risk for cavitation. However in damper applications the influence from temperature variations is normally relatively small compared to the influence from pressure variations.

In non-TTX type dampers, pressure drops are found at the backside of the main piston and at the outlet of the valves. If the volume of fluid where the pressure drop happens is pressurised high enough, the produced gas bubbles caused by delays in the pressure distribution will disappear right away. As these small bubbles only occur very locally in direct proximity of the piston/valves this phenomenon is sometimes called "local cavitation". However, cavitation normally refers to conditions where the pressure is low enough to make the small gas bubbles combine to large volumes of gas. If these volumes of gas pass through the valves instead of damper fluid, the damping will go away.

When the gas bubbles are exposed to higher pressure, they will implode. These implosions could cause damage to damper, so called cavitation pitting. Often sounds from the implosions can be noticed as a hissing or gurgling sound. As most dampers use shimmed main pistons, damage from cavitation is normally found at the outlet ports of the pistons. The damage is very dependent on the geometry of the piston.

In a conventional damper, the cavitation starts during the compression strokes. If the absolute pressure (see below) on the rebound side drops too much during a compression stroke, gas bubbles will occur. This leads to a stop in pressure drop on the rebound side. The volume increases as the oil changes from fluid to gas and oil from the compression side is dumped into the reservoir. Any additional damping force will come from increased pressure on the compression side. On the following rebound stroke, there will be a lack of oil on the rebound side and this will lead to a delay in the rebound damping force build up.

Most conventional dampers have some type of reservoir valve. This valve is often referred to as a compression valve, but the main purpose of this valve is to improve damper response and reduce the risk of cavitation.

By adding a restriction in the reservoir, the absolute pressure on the compression side will be higher for a specific compression damping force. This means that the pressure on the rebound side does not have to drop as far to achieve the same pressure differential across the valve. This shortened pressure drop allows that differential to happen in less time, which equals response time, and also keeps the rebound pressure away from the cavitation limits. This may decrease the risk of cavitation, but it adds hysteresis to the damper.

In a conventional damper with no reservoir valves, the available damping force before cavitation can be estimated from the formula below.

$$F_{\text{max comp}} = p_{\text{reservoir}} \cdot A_{\text{rebound}}$$

$p_{\text{reservoir}}$ = reservoir gas pressure
(not absolute pressure)

A_{rebound} = area of the rebound side of the main piston
(piston area minus rod area).

Always try to stay with the recommended gas pressure and keep the extra margin against cavitation by adding reservoir damping. In the TTX, the risk of cavitation is always minimised. Check valves prevent the pressure from dropping below the set gas pressure. This results in always having the same good margin for cavitation, no matter how high the damping forces are. Cavitation in the TTX can only occur if the oil isn't pressurised. Even a tiny pressurisation of 1-2 bar (15-30 psi) is enough. There will be no pressurization of the oil if

- The reservoir is not pressurized
- There is too little oil in the damper.

If the oil level is to low, the separating piston won't be pushing on the fluid and can't add any pressure to the damper fluid. The reason why some pressure has to be added to the damper fluid to avoid cavitation in the TTX is that there will always be small areas with pressure drops in channels and check valves.

The easiest way to study cavitation in a dynamometer is to reduce the reservoir gas pressure. Continuous measurement is the best way to identify cavitation, as the acceleration and deceleration part of the damping curve separates due to the delayed damping force build up. In a conventional damper the delay will mainly be noticed on the rebound side. While in a TTX the delay will very much less. In a TTX there will be about the same delay on compression and rebound. Even with constant velocity or peak velocity measurement, cavitation can sometimes be observed. However it will be more difficult to know if the loss in damping force actually is due to cavitation or some other factor.

9 - Cavitation

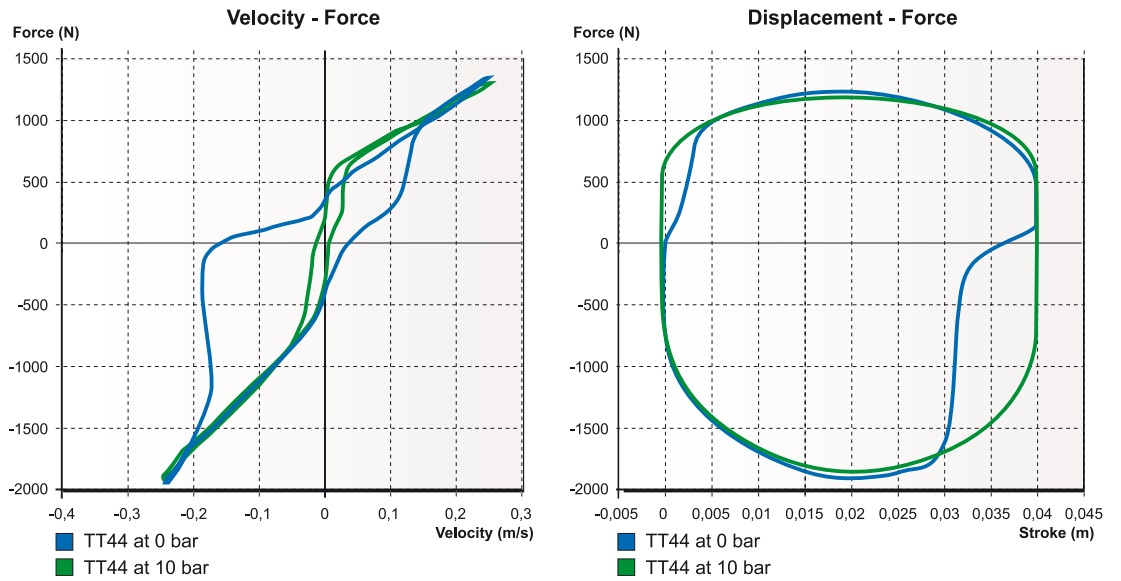

Figure 9.1
 Example of cavitation in a TT44 tested at 0 bar of reservoir gas pressure. The curves are produced at continuously force measurement at a sine wave cycle with peak velocity 0.25 m/s.

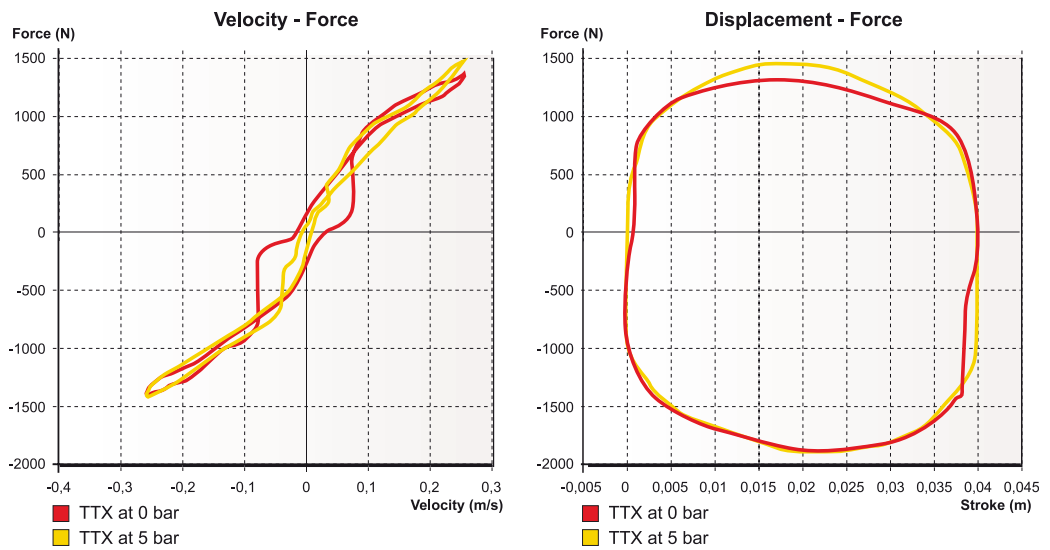

Figure 9.2
 Example of cavitation in a TTX tested at 0 bar of reservoir gas pressure. The curves are produced at continuously force measurement at a sine wave cycle with peak velocity 0.25 m/s.

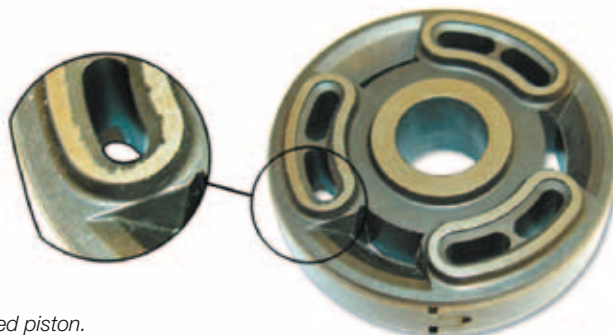

Figure 9.3
 Example of cavitation pitting on a shimmed piston.

For some period in history, damping came mainly from friction. For example, a leaf spring friction on trucks gives damping. As the damping characteristics of friction are maximum force at the start of the movement and normally with little or no relation between friction force and velocity. Friction doesn't result in a desired damping characteristic for a vehicle. The level of friction is also hard to control. As racing teams always try to optimise everything to gain performance, the levels of friction can not be neglected.

It is normally hard to quantify the level of friction in the suspension as it depends on the loads. When it comes to the dampers, the spring element used is a determining factor. Coil over springs always cause bending forces to the dampers, as the springs are not perfect. Here the main friction comes from the bushings. The design of the TTX40/TTX46 MT will guarantee minimum friction forces when subjected to side loads.

There are always some variations in friction between individual dampers. After the dampers have been run in, the friction will be reduced. Without side loads, the friction levels of a TTX40 could be expected to be in the region of about 15 - 17 N in sliding friction and about 22 - 24 N in starting friction. One reason for these low values is the low gas pressure. Another reason is that the separating piston doesn't move as the piston rod displaces oil. Therefore, there is no friction from the separating piston. If side loads are added, it is hard to give some exact numbers of how the TTX40/TTX46 MT perform friction wise compared to for example a TT40, as is very much depends on the spring used and the position of the piston rod, but a reduction of friction with about 50% can easily be found.

Many times but not always, a swivelling spring retainer and/or spring platform reduce the friction from side loads caused by coil springs. In the figure below shows how the friction force varies over the stroke in a TT44 with different combinations of spring retainers and spring platforms. The best combination depends on the position of the piston.

Note!

The figure here is only for illustrating the trends for a non through rod damper. The numbers are only true for this particular hardware combination.

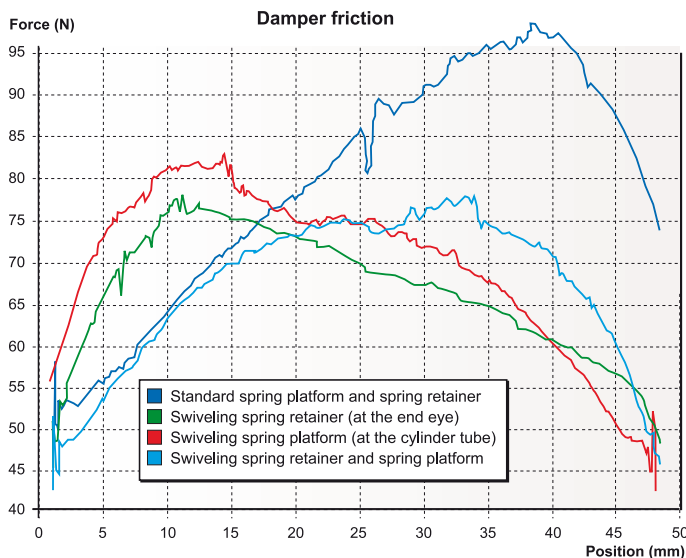

Figure 10.1

Damper friction verses stroke in a TT44.
The higher the position number is, the more compressed the damper is.

11 - Temperature Stability

In all dampers, the damping force changes due to temperature variations. As the viscosity drops when the temperature rises, the damping force will drop unless there is some “compensation”.

The word fading is often used for this loss of damping. The compensation is normally done by using materials in the bleed needle and housing, so the opening of the bleed path is reduced as the temperature goes up. An enclosed volume of fluid can also be used to push the needle closer to the seat. The lengths of the two parts have to be correct to get an acceptable compensation. However the compensation can never be perfect and any overcompensation is objectionable.

How much focus there is on fading varies. On most applications, the temperature rapidly reaches a constant operating temperature. In single seaters, there is generally a fairly low amount of energy absorbed by the dampers. Therefore, the temperatures are normally very stable – in the front they stay low and in the rear they are kept high by the engine. See the chapter Temperature range for recommended temperatures. In applications where a lot of energy is absorbed by the dampers, fading might be more of a concern.

The amount of fade will depend on the type of flow through a valve. Flows are divided in to two different categories – laminar and turbulent. In general, laminar flow occurs where the area change is gradual and the restriction is extended in length. Turbulent flow results from an abrupt area change. Also, the velocity of the fluid moving through the valve has an influence on the type of flow. Increased velocity increases the amount of turbulent flow. At laminar flow, the restriction depends on the viscosity, while turbulent flow is not as sensitive to viscosity changes.

The drop in damping force is not linear with respect to temperature and depends on the fluid used. The Öhlins 309 oil for instance drops little in viscosity above 50°C.

It is very hard to give correct values on how much fading there is in a damper as there are huge variations, both in force and in percentage of force, due to settings and velocity. The settings include both hardware and how the adjusters are set. Expressed as percentage of drop in damping force, fading will always go down as the velocity increases. In general, compared to a TT44, the TTX40/TTX46 MT fades more at lower damper velocities while the TT44 drops more at higher velocities.

👁 Note!

For simulations, keep in mind that the actual damping force you have on the car might be lower than what the dynamometer testing at room temperature indicates. For this reason dynamometer testing for this purpose should be done at operating temperature. When only comparing settings, dynamometer testing can be made at room temperature if it is always done this way.

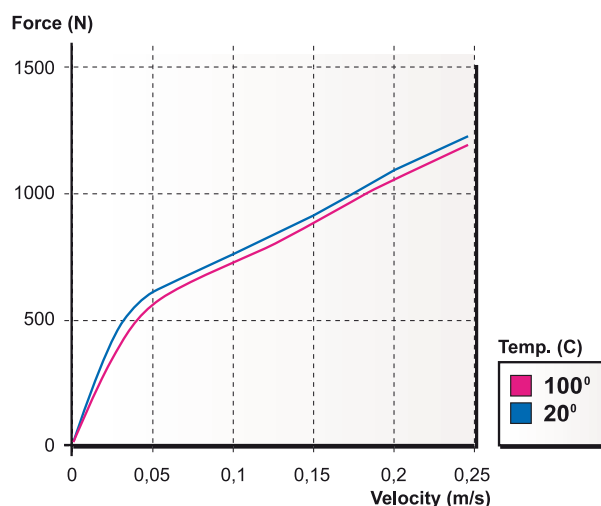

Figure 11.1

Example on how the damping force can drop in a TTX40 if the temperature raised from 20° C to 100° C.

By Bruce Burness

Historically, dampers were asked only to provide a comfortable ride. If you were lucky, driver controllability was enhanced at the same time. With the advent of ground effect aerodynamics in the late seventies, racing engineers discovered that damper settings are a valuable tool for optimising “aero” effects. At the same time, the tire companies found they needed to redesign their tires to take advantage of the downforce created by the new ground effect aerodynamics. The mechanical grip of these new tires also turned out to be extremely sensitive to damper settings. These developments doubled the number of duties required of dampers of today. The priority list today for racing damper functions is “aero” management, mechanical grip, tire wear, driver controllability and ride comfort. Dampers have a powerful influence on the performance of your car.

These five damper functions are all interrelated but at the same time optimising one of these functions can sabotage another. A compromise between function goals is many times unavoidable. Finding the most effective compromise is the overall goal and will pay dividends on the racetrack.

Comfort, grip and control

These five goals are so tightly interwoven that most of the time it is very difficult to make a damping change and then properly assign the performance gain or loss to the correct category. For example, let us say you have added some extra compression damping to the front dampers and now the front tires have gained grip. The question is did we create pure mechanical grip from the tires or is the gain from improved aerodynamics or from better dynamic fore/aft pitch control or possibly a higher dynamic ride height or centre of gravity which could also change dynamic roll centres. It is not essential to know the exact cause and effect, but it is possible through a cleverly planned sequence of subsequent tests to better isolate the gain and assign it to the correct category. If this is achieved, the focus of further testing will be more on target and the possibility of a wayward theory will be minimised.

All this may sound too hypothetical but rest assured if you optimise the aerodynamic potential without compromising the grip and then find the mechanical balance by adjusting the springs, sway-bars, etc. the driver controllability will most likely be there automatically. The ride comfort may be compromised but do not be too concerned. Even though Öhlins dampers generally produce an improved ride quality, we have found that damper settings that give too much comfort cannot provide optimum grip or controllability.

Aerodynamic management

In this ground effect age, dampers can maximise the amount of downforce generated by the underside of the car by assisting in maintaining a constant air gap between the underside and the ground. Today we have basically two types of formula car ground effect configurations, *tunnels* and *flat bottoms*. With both types the clearance between the underside and the ground is very critical. Generally there is a ride height “sweet spot” that is favourable for generating high downforce with a minimum of “aero” drag. The problem is that this “sweet spot” is very close to the ground. Good damper settings will keep the car at this ideal ride height a higher percentage of the time through most dynamic conditions without allowing the underside to contact the ground (bottoming).

With both tunnel and flat bottom cars the centre of the downforce is found where the geometry of the underside comes closest to the ground. With either type of car the centre of downforce migrates with any change in pitch angle in relation to the ground caused by braking, cornering or acceleration.

This migration of the centre of downforce alters the handling balance by increasing the downforce towards the direction of migration and reducing the downforce away from the migration. Therefore, added tire grip will occur at the end of the car that moves closer to the ground.

Tunnel cars have far less downforce migration than flat bottom cars because the contour of the tunnel is curved in the shape of a venturi with a raised entry that curves down to a short flat area followed by a long, slowly enlarging exit. Tunnels are generally positioned near the vehicle centre of gravity. The tunnel flat part is in the closest proximity to the ground and that is where the centre of downforce occurs. When the car pitches fore or aft this part of the tunnel primarily rocks back and forth and does not raise or lower significantly. Tunnels minimise downforce migration.

Flat bottom with diffusers

On the other hand, flat bottom cars with diffusers can have the downforce migrate from just ahead of the diffuser at the back all the way to the tip of the nose under braking. For cars with raised noses the migration will essentially stop where the underside begins to move away from the ground. Flat bottom cars are much more sensitive to static and dynamic pitch changes than ground effect cars. Damper settings for flat bottom cars therefore need to be biased more towards pitch control than the settings for tunnel cars.

Both tunnel and flat bottom cars can also benefit by keeping the underside parallel to the ground, side to side, while cornering. In this case, the downforce migrates from side to side but also will diminish substantially if the inside of the car raises away from the ground. For cars that turn only one direction as on an oval, sometimes higher corner speed can be achieved by increasing the compression damping and reducing the rebound on the right side (outside) and the opposite on the left side (inside).

Mechanical grip

Compared to aerodynamics, understanding the dynamics of tire grip is more elusive and the perceived rules change from one type of tire to another. It seems tire grip is created when the tire is pressed into the track surface enough to cause the rubber to interlock with the grain of the pavement. Not enough compression damping allows the tire to move freer and ride up on top of the pavement grain, metaphorically similar to “dry aquaplaning”. As the compression damping is increased, the tire will interlock with the pavement and grip will increase.

If the damping is further increased incrementally, eventually the grip will stop improving and begin to go down. This is mainly caused by too much pressure from the suspension that overheats the tire or compresses it too much, giving unduly high tire load variations. Keep in mind that the suspension pressure the tire feels is the sum of the compression damping, the spring rate, the sway-bar rate and possibly the torsional rigidity of the chassis. If the pressure sum seems to be optimised for grip but for other reasons it is indicated that one component of the sum needs to be increased, another component may need to be reduced.

For instance, a higher spring rate may be necessary to reduce fore and aft pitching. In order to make the stiffer spring work properly, the compression damping may need to be reduced. In another case, one car might have less torsional stiffness in its chassis than another. To compensate for this, the car with lower chassis stiffness will require more compression damping to make the suspension pressure sum high enough. An indicator of too much suspension pressure is controllable sliding at all speeds and all phases throughout the turns (flat sliding).

12 - Damper Functions

Grip and rebound damping

Grip in relation to rebound damping works in a slightly different manner. Rebound damping only occurs after there has been some compression of the damper and spring. The pavement grain constantly causes small wheel movements of the suspension system. The rebound damping controls the expansion in these small displacements. If the rebound damping is excessive, the expansion will be too slow leading to a loss of grip. This type of grip loss will be particularly noticeable in rear tire forward traction with the application of power. Cornering grip will not be as dramatically effected as forward traction.

If a lot of rebound damping is used the suspension will be dynamically pumped down which can improve the aerodynamic downforce. If there is enough "aero" gain it can more than offset any loss of grip due to slow rebound recovery. When this approach is used compression damping is generally reduced at the same time to help the pumping down. We have seen success with this approach, but today most teams are pursuing the high compression, low rebound technique with even better results. Both philosophies have their place. It seems that in the classes where the downforce potential is much less, the proportion between compression and rebound damping leans towards less compression and more rebound damping.

Driver controllability

In most cases vehicle stability will be quite acceptable when the damper has been adjusted for optimum "aero" and grip management. Sometimes "aero" and grip need to be slightly compromised in order to adapt to the style of different drivers. In the final analysis a car that is more driver friendly will prevail over a car with ultimate grip that is also nervous.

Tire wear

Sometimes settings that are good for qualifying can be too hard on tires after a lot of laps. Our experience suggests slightly more compliant damper settings for the race than those used during qualifying.

Ride comfort

One final word about ride comfort. Harshness is either from a suspension that is too stiff to comply with bumps or from a suspension that shakes because of inadequate damping. Deciding which condition exists in your car plus a review of your damper settings can guide you in solving harshness problems.

It is not our intention in this chapter to cover all questions about how to find a good damper set-up. However, we offer some basic rules to help you set up the car. The first time the TTX40/TTX46 MT is installed on the vehicle our recommendation is to match the damping curves previously used. However, as the TTX40/TTX46 MT will have at least as quick damping force build up as the damper you are replacing, you might have to lower the damping force on the TTX40/TTX46 MT to find a better set-up.

If there is no history when it comes to damping forces, some calculations, simulations or shake rig testing might be needed to find the correct amount of damping. If "aero" isn't taken in account, there will be no information about the distribution compression to rebound damping. Also, the damping curves may need to be reshaped from the maximum grip level to achieve an acceptable vehicle handling. Here experience is extremely useful.

In general, our recommendation is to start with linear damping curves and add knee if necessary.

When comparing damping curves, keep in mind that the motion ratio must be the same. The damping forces at a different motion ratio could be estimated by scaling the forces with the square of the quotient of the motion ratios. If the damping curves are not very linear, you have to do a more proper calculation by scaling both the forces and velocity with the quotient. One of them should be multiplied with the quotient the other divided. See the end of this chapter for some more detailed information. Having intimate knowledge of your damper mounting geometry is the key to predicting the proper amount of damping forces.

If your racecar has handling problems, determine first if it is damper related or not. Because dampers have proved to have such a profound influence on handling, some race engineers are in the habit of tuning the dampers before making "aero" or mechanical adjustments. As damper manufacturers, we are flattered, but there are limits to the problems that can be solved by damping adjustments. If a problem can be improved by "aero" or mechanical changes, it is wise to make those changes first.

To make improvements, it is important to understand the function of the dampers. Then through testing, learn how the dampers influence the handling of your car. When making adjustments, keep notes, make adjustments one at a time and in small steps. Always pay attention to changes in conditions like tire wear, track temperatures, time of day, etc. At the end of the test session, go back, if possible, to the starting set-up to double check that an improvement has actually been achieved.

We recommend limiting changing of the low speed adjusters to steps of no more than 6 to 7 clicks at the time. Too large a change can jump right over the optimum setting and sometimes result in similar handling as the original setting. We normally recommend changes of 3 to 4 clicks. When you are near the optimum setting the driver can notice such a little change as 1 or 2 clicks. When both compression and rebound are near optimum a final adjustment might require a trade of one less rebound click for one more compression click or the reverse.

A logical reason for opening only the compression low speed adjuster could be a desire to reduce harshness, to slow down turn-in, or to search for more mechanical grip. The limits to how far the low speed adjusters can be opened are instability, bottoming, lazy turn-in, not enough roll support, braking problems or loss of grip.

Opening the low speed rebound adjuster usually results in more grip especially in the rear during power-down conditions.

As the low speed adjusters are changed, the knee will occur at a different velocity. This affects the high speed forces. The more slope there is on the high speed, the more the high speed will be affected. This can be compensated by changing the high speed adjusters to raise or lower the knee.

Raising the knee (mainly on compression) can result in more support. Raising the knee can also be an effective way to control the underside rake angle, in either the front or rear. Lowering the knee can reduce harshness.

The more pronounced knee you have the more feedback the driver will get. There is often a trade off between feedback and grip/traction.

Reducing the compression slope might be called for on bumpy street courses if your car has difficulty absorbing bumps causing harshness. You might want to increase the compression slope if the car bottoms easily or if roll support seems inadequate. This could also be advantageous on bumpy circuits where bumps cause big chassis movements.

Also, if you determine the knee needs to be reduced, increasing the slope at the same time is sometimes a good idea. The converse is also true.

To compensate for motion ratio changes, both high and low speed have to be changed.

It is not easy to have some general rules about in what range the adjusters should be set, as the needs can be very different depending on the vehicle. However for race cars with damper/wheel bell crank (rocker) ratios of around 1.0/1.0, the low speed compression (LSC) very often ends up at a clicker position in the range of 6 to 14. The corresponding range for the low speed rebound (LSR) is 15 to 25.

If your bell crank ratio moves the damper slower than the wheel, the clickers will need to be set to lower numbers to give more low speed damping. The reason is the wheel has mechanical leverage over the damper and the forces from the damper will end up less effective at the wheel. In addition, the leverage also causes the damper piston speed to be lower. Thus the original damping must be multiplied by the change factor and then the new damping force must be moved to a lower piston speed this time dividing the speed by the same factor. To compensate for the leverage changes, tighten the low speed adjuster and add preload with the high speed adjuster.

Conversely, if your bell crank ratio moves the damper faster than the wheel the adjusters need to be set to higher numbers to give less damping and the damping change factor now needs to divide the original damping and multiply the piston speed.

14 - Gas Pressure

A good rule is to stay with the recommended pressure. For the TTX40/TTX46 MT this pressure is 5 bar (75 psi). In the TTX40/TTX46 MT, different gas pressures have no influence on the damper characteristics. For instance a range of 2 to 10 bar can be used with no influence on the characteristics. Even going higher than 10 bar will not effect the damping characteristics but it will exert unnecessary forces on the damper parts. Be aware that at 0 bar, there will be cavitation.

⚠ Warning!

Never run the TTX40/TTX46 MT damper at higher gas pressure than 10 bar.

Always pressurise the damper at room temperature. Use nitrogen gas only. It is an inflammable gas with no effect on the material in the gas reservoir.

See section *Using the gas filling device* in the work shop manual for how to pressurise and depressurise the damper. If there are any doubts, please contact an Öhlins distributor.

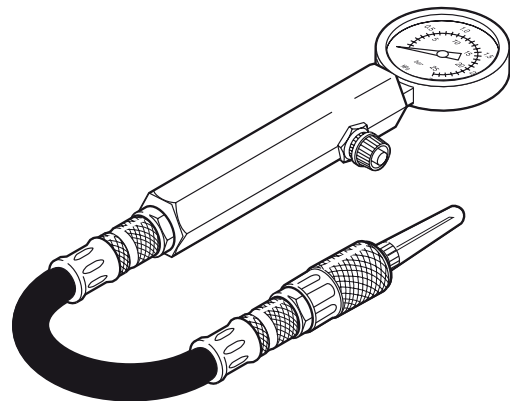

Figure 14.0
Gas filling device

15 - Temperature Range

The working environment for the damper is important to its function and life. You should always pay attention to the damper temperature. Low temperature is normally not a problem with the TTX40/TTX46 MT damper. The problem is high temperatures. Some heat is generated by the damping energy, but most of the heat comes from being in close proximity to engine or brake parts. Try to keep the temperature below 90°C (approx. 200°F). If the damper runs hotter than 120°C (approx. 250°F), try to vent some fresh air to the damper. Heat shields may be necessary. Naca ducts in the engine cover also help cooling. If your vehicle has the exhaust system on one side only, a larger naca duct on that side can equalise the temperature of both dampers.

The gas volume is not stroke dependent, but remember that the gas volume will decrease as the oil expands from the temperature change.

👁 Note!

Many times the temperature variation is the problem, not the temperature itself.

⚠ Warning!

Always pay attention to the position of the separating piston.

See section *Revalving* in the Work shop manual for information.

To cool down the dampers, when they come off the car, some teams put them in a can of cold water. This is not recommended.

However if this happens, put the shock in with the cylinder head down. Trapped air will help prevent water from reaching the internal piston rod. Also, spray some WD40 or similar into the holes of the top eye to protect the piston rod. Otherwise, the end of the piston rod will rust. Make sure the rust preventive being used doesn't cause damage to rubber.

It is hard to give recommendations about servicing dampers as the conditions vary a lot. For example, during hot and dirty conditions the maintenance has to be done more frequently.

An example of a recommended inspection and maintenance schedule for a Champ car team starting to run TTX40 dampers is as follows.

Note!

Depending on the results of the inspections below, the time between the inspections can be changed.

Every race weekend

- Measure the position of the separating piston. This should be done several times during a race weekend. On the TTX40 this is a very quick operation. See section *Adjusting the oil level* in the Work shop manual.
- Look for oil leakage. By keeping the damper clean and dry, any leakage will be easy to detect. If oil is leaking from the X-ring seal repeatedly, replace X-ring and inspect the piston rod for imperfections on its surface.
- Inspect the dampers for external wear or damage.
- Check the spherical bearings regularly for excessive play. On installations where the spring is not of coil over type, a gap is more critical as the bearings will see loads in both directions.

Every third to fifth race weekend

- Inspect the piston ring for wear occasionally by measuring the height and width of the piston ring.

Note!

The piston ring of the TTX40 is a seal and not a bushing and it does not take any side loads so wear should be minimal.

See the figure below for smallest accepted dimensions of the piston ring. Replace if necessary. See section *Rebuilding the damper* in the Work shop manual for information about how to remove the piston ring.

- Check the condition of the inside of the inner tubes. See section *Rebuilding the damper* in the Work shop manual for information about how to remove the inner tube.
- Examine the sealing surfaces of the valves and the check valves. These consist of the valves, the seats and the nose shims. The sealing surface of the nose shims will become polished, but as long as no significant wear is noticed, they won't have to be replaced. The same thing is true for the check valve shims. See section *Revalving* in the Work shop manual.
- Examine the surface of the needle housing where the coil springs is seated.

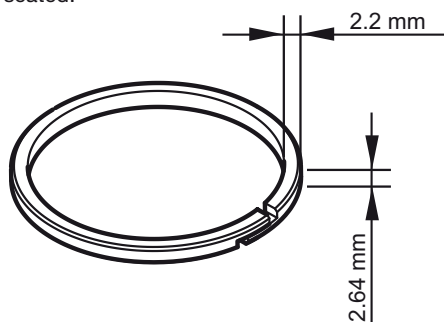

Figure 16.1

Smallest accepted dimensions of the TTX40 damper piston band.

Every tenth to fifteenth race weekend

- Inspect the condition of the two piston rod bushings. Even if some of the PTFE (grey colour) covering the surface of the bushings is gone, they still perform fine. If all of the PTFE is gone, the bushings should be replaced. No Loctite is needed. If assistance is needed, contact Öhlins distributors.

It is hard to give some general recommendations when to change the oil as the conditions vary greatly. If the oil has changed colour and smells bad the oil should be changed. In hot conditions, in the region of 90°C (approx. 200°F) begin to inspect the oil after about 1500 km (approx. 1000 miles). Only use Öhlins damper fluid 309. If any o-rings need to be replaced, always apply Öhlins red grease (part no. 00146-01) to the new o-rings. The same thing applies to the threads where no Loctite is used.

A dynamometer is a good tool to find failures in the damper. Therefore, we recommend doing regular dynamometer testing. For example leakage, check valve problems, etc, can be detected. See chapter *Damping force measurement* for more information.

At least once every season, we recommend complete disassembly of the damper for visual examination. Ask your Öhlins distributor for help or advice if needed.

Warning!

Make sure the chemical substance used for cleaning the dampers does not harm rubber and plastic.



Figure 16.2

Area to inspect at the needle housings.

17 - Actions after Crash or Fire

The damage to a car involved in a crash very often gives a good idea if the dampers are intact or not. If you suspect that there is a risk that something has happened to a damper, you should remove the damper from the car for closer inspection.

First, check for leakage and new external marks or cuts on the damper you haven't seen before. If you find something, you have to inspect the damper carefully to determine what is damaged.

Slowly compress the damper by hand and pay attention for variations in friction. Increased friction is often an indication of a bent piston rod. The straightness of the piston rod should always be checked and be within 0.05 mm (0.002 inch). If possible, make a dynamometer test to ensure that the damping forces reproduce correctly.

A crash sometimes results in cracks in the damper materials. The cracks may be hard to detect with the bare eyes, so Öhlins always recommends making a magnaflux inspection on the parts that could be damaged. If no special indications of damage can be seen, these parts should always be checked: top eye, cylinder head, outer tube, piston rod and end eye.

If the dampers have been in an area of fire, the heat might have had an effect on the material. The rubber seals are the most sensitive parts and should always be replaced. Also, check the plastic parts like spacers, bushings etc.

When opening a damper that has been in a fire, ensure the ventilation is good and avoid getting the oil on your skin as it might be harmful.

Note!

Glued parts can come loose.

Even with no visible damage to the metal parts, the heat might have affected them and the strength of the materials can be reduced. By measuring the hardness of the materials, you can find out. If the hardness has gone down, the parts should be replaced.

If the dampers have been at a very high temperature, not only in a fire but anything that may cause unusually high temperatures, there is a risk that the separating piston will bottom out. If so, the cylinder head could start to deform at the circlip holding the reservoir end cap. Therefore inspect the top of the cylinder head carefully.

If in doubt, always replace the parts.

18 - Valving Reference Program

One of the advantages with the TTX40/TTX46 MT is the ability to use the VRP (Valving Reference Program). It enables you to research the damping forces without dynamometer testing. You virtually build your damper in the computer using different combinations of clicker settings, valves, poppets, nose shims, shims stacks and valve springs. The program will then present the Compression and Rebound dynamometer curve for your specific setting. This will make the work easier and quicker for both mechanics and engineers. No manual today with valving charts can cover as big range of combinations of adjustments and settings as the Öhlins VRP does.

Normally, a lot of dynamometer testing is necessary to find the setting that produces the desired damping curve. This results in a lot of work since usually the hardware has to be changed several times during this process. With the VRP this is not necessary. The VRP should be seen as a complement to the dynamometer, not as a replacement.

The dynamometer is still needed to ensure that the correct damping forces are achieved. This work will be made much easier by using the VRP, since comparing the dynamometer forces with the VRP forces can be done with any combination of valves and clicker settings desired. The damping forces illustrated in the VRP have been measured in an Instron dynamometer at constant velocity.

👁 Note!

If these forces are compared to forces from a dynamometer measuring the forces continuously (crank dynamometer), there will be some differences. For best results, use peak velocity measurements on a crank dynamometer. See chapter Damping force measurement.

Of course it is possible to use nose shim stacks or shim stacks not covered by the program, but there should be little need for this. The TTX40/TTX46 MT VRP is free of charge on the Internet at www.ohlins.com. The TTX40/TTX46 MT VRP is basically self-instructive, but there is also a text instruction available in the program.

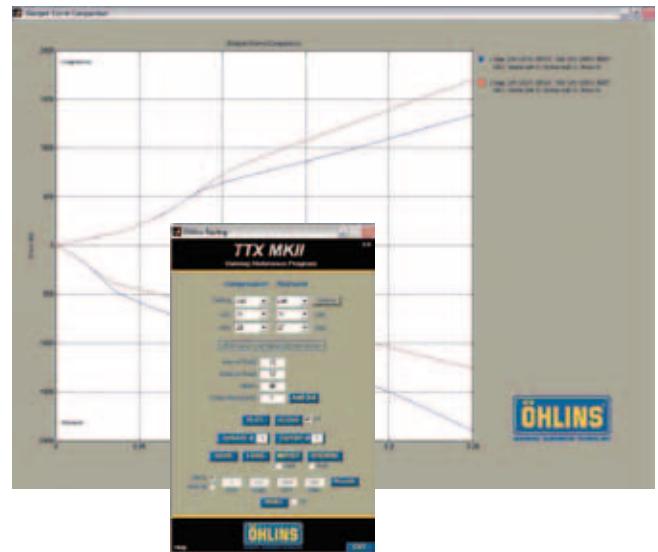

Figure 18.0
VRP desktop interface.

19 - Damper Configuration

The TTX40 damper is available with different strokes. To minimise the damper length needed for a given stroke, the external and the internal stroke is the same. The exception is the TTX NE02, TTX NE04, TTX NH02 and TTX NH04 that has 15 respective 21 mm external spacers and TTX NH06 and TTX NH08 that has 10 mm less external stroke than internal. This is due to that the TTX NH06 and TTX NH08 has a lock nut that is 10 mm higher to increase the strength of the shaft.

On the TTX NH06 and TTX NH08 it is possible to use the same nut as the TTX NH01-04 and gain 10 mm stroke, but in the same time lose some strength. A small difference ensures a well defined external bottoming. The external stroke is approx. 0.5 mm shorter than the internal stroke (except TTX NH06 and TTX NH08 with the higher lock nut, see above). There is also approx. 0.5 mm in distance between the internal piston rod and the bottom of the top eye at fully compressed position except for the TTX NE01 and TTX NH01, where the distance is 3.5 mm.

To ensure a correct assembly of the dampers including dynamometer testing and still give the customers freedom to configure their dampers, the dampers are sold without end eyes, spacers or spring platforms. The TTX46MT comes with upper and lower spring platforms, sway bar bracket needs to be ordered separately. We call this unit the "damper unit".

The TTX40 damper is designed to fit 2 inch i.d. springs. Platforms for 2.25 inch i.d. springs are also available. It is also possible to run 36 mm (1.5 inch) i.d. springs. If so, the spring platform is placed on the end cap of the cylinder body.

The TTX46MT damper is designed to fit 60 mm (2.36") springs.

To get your desired damper configuration pick

- Damper unit (TTX40 or TTX46MT)
- End eye (only TTX40)
- Spacers for spherical bearings ("top hats") to top eye and end eye (only TTX40)
- Spring platform (only TTX40)
- Spring retainer (spring platform at end eye) (only TTX40)
- Internal spacers (TTX40 and TTX46MT)
- External spacers (only TTX40)
- Packers (only TTX40)
- Sleeve (for tube protecting) (only TTX40)
- Sway bar bracket (only TTX46MT)

The rubber caps (part no. 05925-01, included in the kits) can be fitted to the valve end caps to protect the adjusters from dirt. The cylinder tube protecting sleeve (part no. 06140-01, TTX40 only, not included) is useful when 2 inch i.d. springs are used as there is a risk of the spring contacting the outer tube. When long springs are used, this risk increases. The protecting sleeve is installed with spanner part no.00738-01 together with mounting sleeve part no. 00737-04. Torque: 30 Nm (22 lbs.ft.). As the torque can't be measured, it has to be estimated.

Note!

The lock nut for the end eye (part no. 06117-01/-03, TTX40 only) together with the plastic spacer (part no. 05449-03/-06, TTX40 only) covering this nut are installed on the damper unit. A set screw (part no. 05410-01, 3 pcs together with TTX46MT) for the spring platform also comes with the damper unit. If bump rubbers will be used, an external spacer must be used to prevent bump rubber damage caused by the holes in the end cap (TTX40 only).

See the Spare Parts List for the TTX40 or TTX46MT for identifications of parts. In the Spare Parts Lists you also can find some more additional parts. Always make sure that you have the latest Spare Parts Lists to keep updated with new additional parts.

19 - Damper Configuration

Figure 19.1

Table with parts needed to complete a TTX40 damper.

Damper unit / Stroke [mm]	End eye	Bearing spacers	Spring platform	Spring retainer	Internal spacers	External spacers	Packers
TTX NE01 / 48	06136-01 2)	05425-XX 5)	05964-01 (2")	05441-01 (1.5")	06132-01 (1 mm) 8)	06130-01 (1 mm) 8)	06131-02 (2 mm) 8)
TTX NH01 / 48	06136-02 2)	05518-XX 5)	05964-02 (2.25")	05411-01 (2.25")	06132-02 (2 mm) 8)	06130-02 (2 mm) 8)	06131-03 (3 mm) 8)
TTX NE02 / 56	06136-03 2)	06119-XX 6)	05972-01 (1.5") 7)	05411-02 (2")	06132-05 (5 mm) 8)	06130-05 (5 mm) 8)	06231-02 (2 mm) 9)
TTX NH02 / 56	06136-04 2)			05411-03 (2.25") 4)	06132-10 (10 mm) 8)	06130-10 (10 mm) 8)	06231-03 (3 mm) 9)
TTX NE03 / 68	06136-05 2)			05412-01 (2.25")	06242-02 (2 mm) 9)	06233-01 (1 mm) 9)	
TTX NH03 / 68	06136-06 2)			05965-01 (2")	06242-05 (5 mm) 9)	06233-02 (2 mm) 9)	
TTX NE04 / 80	06136-07 2)				06242-10 (10 mm) 9)	06233-05 (5 mm) 9)	
TTX NH04 / 80	06133-01 3)					06233-10 (10 mm) 9)	
TTX NE06 / 110	06219-01 2)/4)						
TTX NH06 1)/ 100	06219-02 2)/4)						
TTX NE08 / 140	06219-03 2)/4)						
TTX NH08 1) / 130	06219-04 2)/4)						
	06219-05 2)/4)						
	06219-06 2)/4)						
	06219-07 2)/4)						

Note!

If bump rubbers are to be used on a 36 mm (1.5 inch) spring configuration, spacer 05449-xx can be machined down to fit inside the spring. The internal spacers in the 06132 and 06242 series can be used as external spacers.

The parts in the table above are not the only ones that can be ordered, see the Spare Parts List for a complete list. Thus, there is a freedom to build the damper you need. Even if none of the damper units can be used without modifications, Öhlins recommendation is to always order a complete damper unit and modify it instead of ordering all included parts. Pick the unit with the correct tube length and change top eye and/or external piston rod if needed. As the internal piston rod matches the tube length, it never has to be changed unless the tubes are changed.

There could be several different reasons why some parts in a damper unit have to be changed. For instance, a longer top eye might be needed to move the cylinder head away from some interference near the top mount. Another example is, a team optimising the stroke when using bump rubbers.

- 1) Dampers with 14 mm piston shaft.
- 2) Bearing 05536-05 and circlips 05057-04 (2x) have to be included.
- 3) Bearing 05536-01 and circlips 05057-02 (2x) have to be included.
- 4) End eye 06219-xx and spring seat 05411-03 used together. Note that you also need to order circlip 00428-01.
- 5) For ball joint with 3/8" hole diameter (05536-01).
- 6) For ball joint with 1/2" hole diameter (05536-05).
- 7) O-ring 00438-60 has to be included.
- 8) Used together with dampers with 12 mm shaft
- 9) Used together with dampers with 14 mm shaft

For additional parts see the Spare Parts list for TTX40/46MT.

19 - Damper Configuration

As a bump rubber will take some of the external stroke away, a longer piston rod might be needed. When doing this, the length of the piston rod can be calculated by taking into account the type of bump rubber being used and the highest acceptable force from the installed bump rubber. The height of the bump rubber at specified force can be found from a force-position graph.

All damper units except TTX NE02, TTX NE04, TTX NH02 and TTX NH04 come without external spacers on the piston rod. The external piston rod is optimised to match the internal strokes. TTX NE02, TTX NE04, TTX NH02 and TTX NH04 come with a piston rod that would give longer external strokes than internal if there are no external spacers used. This allows the ability to run bump rubbers without losing any stroke, and results in more room for the spring. If the last two digits of the external piston rod part number match the numbers of the damper unit, the external piston rod is optimised to the stroke of the damper unit.

For example, the TTX NE02 and TTX NH02 needs a 06127-02 (is delivered with a 06127-12 piston rod) and the TTX NE04 and TTX NH04 needs a 06127-04 (is delivered with a 06127-14 piston rod) piston rod to have an external stroke matching the internal stroke.

Except for the external piston rods of TTX NE02/TTX NH02 (06127-12) and TTX NE04/TTX NH04 (06127-14), all top eyes (06126-XX for TTX NE0X and TTX NH01-04 dampers and 06226-XX for TTX NH06 and TTX NH08 dampers), internal and external tubes (06110-XX and 06109-XX), internal (06112-XX for TTX NE0X and TTX NH01-04 dampers and 06232-XX for TTX NH06 and TTX NH08 dampers) and external piston rods (06127-XX for TTX NE0X and TTX NH01-04 dampers and 06150-XX for TTX NH06 and TTX NH08 dampers) have numbers that matches their damper unit.

For damper units TTX NE04, TTX NH04, TTX NE06, TTX NH06, TTX NE08 and TTX NH08 (the damper units with the longest strokes and therefore the largest volumes of oil), a reservoir end cap 06121-02 with a larger gas volume is used instead of 06121-01. The stroke of the separating piston will increase by 4.5 mm. If the separating piston is set so there is 1 mm between the tool 01876-XX and the reservoir end cap, the stroke of the separating piston is 5.5 mm with end cap 06121-01 and 10 mm with end cap 06121-02. However the useable stroke is less than that. The internal pressure will otherwise be too high. See chapter *Checking oil level and pressurisation* in the Work Shop Manual for more information.

Note!

Top eye 06126-01, -02 and -03 can only be used with reservoir end cap 06121-01 and top eye 06126-04, -05, -06, -08, 06226-06 and -08 can only be used together with the reservoir end cap 06121-02. Reservoir end cap 06121-01 uses pressure indicator 06105-01 (2x) and end cap 06121-02 uses pressure indicator 06105-02 (2x).

The tool 01876-XX needed to check to position of the separating piston is available in two different versions: 01876-01 and 01876-02. The 01876-01 is used together with top eye 06126-01, -02 and -03. 01876-02 is used together with the top eye 06126-04, -06, -08, 06226-06 and -08. To position the separating piston, an additional tool of the 01877-XX series is needed. For each length of the top eye, a corresponding length of the spacer tool in the 01877 series is required. The last digit of the spacer part number matches the last digit of the top eye part number.

For example a 06126-02 top eye uses a 01877-02 spacer tool. Note that TTX NE06 and TTX NH06 uses tool 01877-26, TTX NE08 and TTX NH08 uses tool 01877-28. Tools 01877-06 and 01877-08 can be used on TTX NE06 and TTX NE08 but not on TTX NH06 and TTX NH08 due to the bigger outside diameter of the top eyes for the NH dampers (14 mm piston shafts).

External and internal spacers together with the available lengths of top eyes, cylinder tubes, piston rods and a large number of different end eyes, give you plenty of freedom to get the damper that you are looking for.

TTX 40

Note!

On the TTX 40 the top eye can be rotated and positioned in any angle to the cylinder head.

See the Work Shop Manual for information about how to relock the top eye. There is also a cross section of the damper, where parameters needed to do length calculations are defined. A table gives the different parameter values available. Some parts are illustrated with dimensions to simplify identification and to help the customers that may need to make these parts themselves, i.e. a custom made end eye.

Note!

All dimensions in drawings, tables and formulas are in millimetres.

Note!

The inner tubes are listed here and they must always have the same number in the last two digits of the part number as the corresponding outer tube. For example inner tube 06110-03 is always used together with outer tube 06109-03. The inner tubes are always 16.5 mm shorter than the corresponding outer tubes.

Formulas to calculate stroke and length follows:

$$FEL^* = A + B + H + D - G - 2.8$$

*FEL = Fully Extended Length

Note!

H in the formula above only refers to end eyes of the 06136 and 06219 series. The fully extended length should be within +1 mm.

$$\text{Internal stroke 1} = B - G - 28.2$$

$$\text{Internal stroke 2} = A + B - E - G + 11.3$$

$$\text{External stroke} = D - F - G - 32.4$$

Note!

The internal piston rod has to be long enough to seal against the X-ring. Formula to calculate the minimum length of the internal piston rod:

$$ML^* = B - G + 13.1$$

*ML = Minimum length of internal piston rod

TTX 46MT

Note!

On the TTX 46MT the gas reservoir can be located either upward or downward. See the Work Shop Manual for information about how to change the direction of the gas reservoir.

TTX 40/46MT

Dimensions of some parts

As some teams might want to make custom end eyes and spring retainers themselves, some key dimensions in the sketches will make this easier. On the following pages you can find the most important drawings and dimensions.

20 - Damper Dimensions

TTX NE01, TTX NE02, TTX NE03, TTX NH01, TTX NH02 and TTX NH03

In the figures below are some external dimensions of the TTX40 damper.

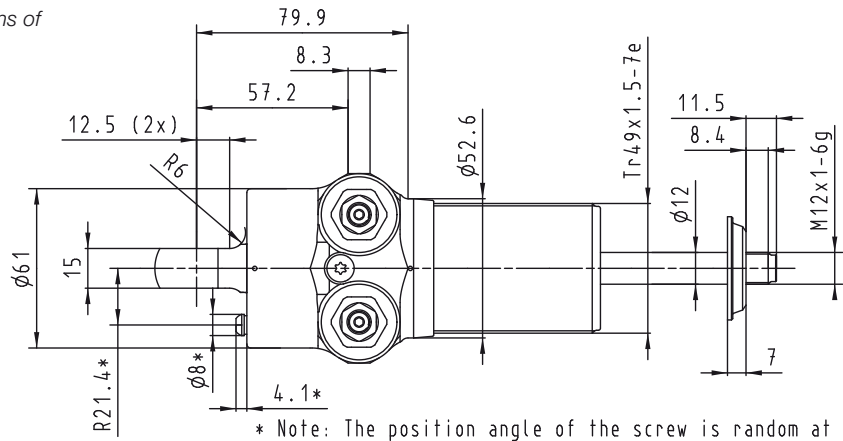

* Note: The position angle of the screw is random at R21.4.

TTX NE01, TTX NE02, TTX NE03, TTX NH01, TTX NH02 and TTX NH03

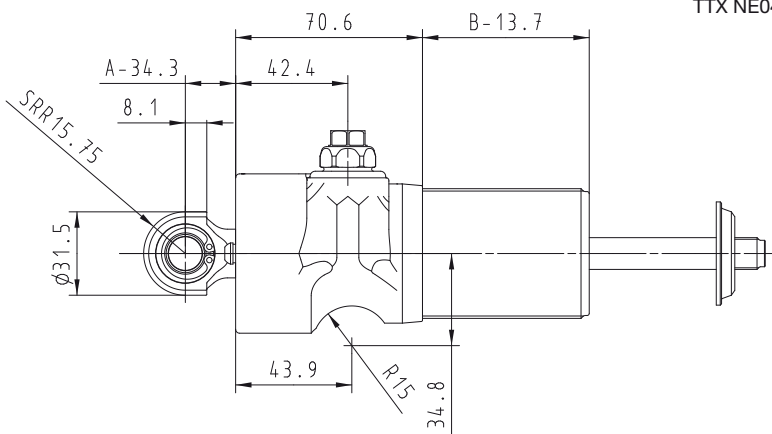

TTX NE04, TTX NE06, TTX NE08, TTX NH04, TTX NH06 and TTX NH08

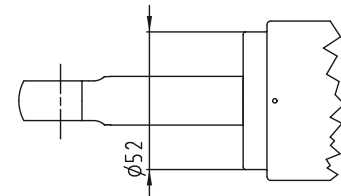
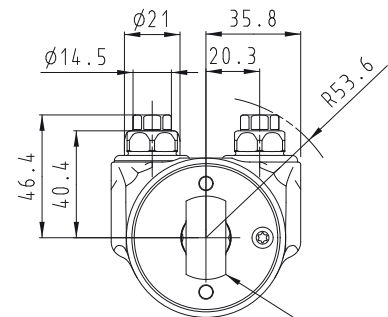

Figure 20.1

Front view of a TTX40 damper unit.

2x of each dimension.



The angle of the top eye is continuously adjustable

Figure 20.3

Top view of a TTX40 damper unit.

TTX NE04, TTX NE06, TTX NE08, TTX NH04, TTX NH06 and TTX NH08

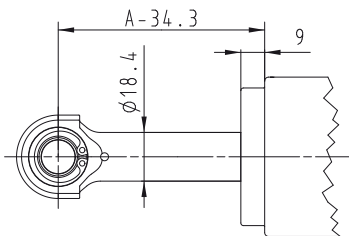

Figure 20.2

Side view of a TTX40 damper unit. See the cross section view below for definition of A and B.

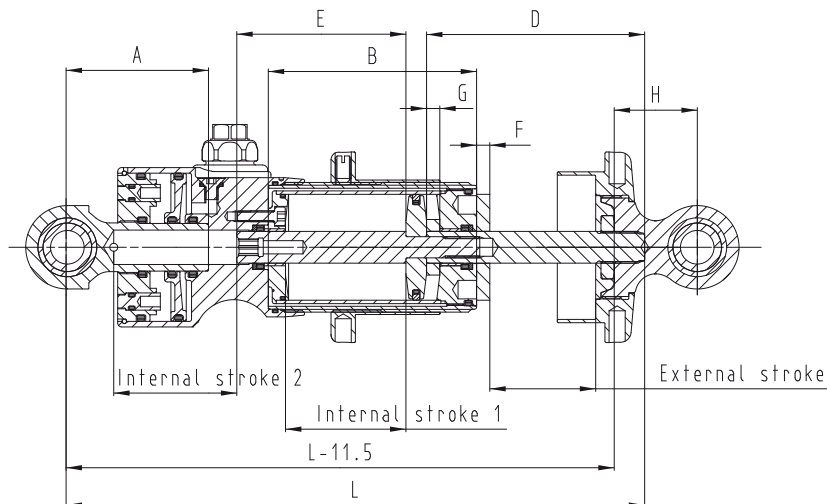

Figure 20.4

Cross section view of a TTX40 damper unit.

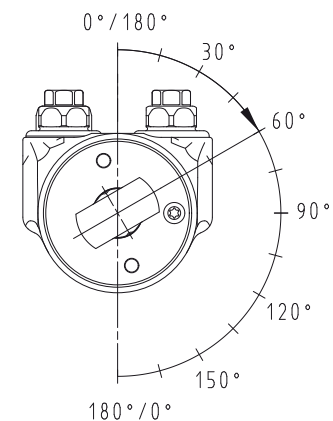

Figure 20.5

Definition of clocking angle of TTX40.

Damper	External stroke	Internal stroke 1	Internal stroke 2	L - 11.5
TTX NE01/TTX NH01	48	48.5	51.5	207.6
TTX NE02/TTX NH02	56	56.5	56.5	243.6
TTX NE03/TTX NH03	68	68.5	68.5	264.6
TTX NE04/TTX NH04	80	80.5	80.5	321.6
TTX NE06/TTX NH06	110/100	110.5	110.5	390.6
TTX NE08/TTX NH08	140/130	140.5	140.5	480.6

Figure 20.6

Table 1 with TTX40 damper unit information.

Damper	A	Top eye	B	D	06109	External piston rod	E	Internal piston rod	F	06130
TTX NE01/TTX NH01	53.3	06126-01	76.7	80.4	-01	06127-01	89.8	06112-01	0	-
TTX NE02/TTX NH02	58.3	06126-02	84.7	103.4	-02	06127-12	97.8	06112-02	15	-05x1 -10x1
TTX NE03/TTX NH03	70.3	06126-03	96.7	100.4	-03	06127-03	109.8	06112-03	0	-
TTX NE04/TTX NH04	82.3	06126-04	108.7	133.4	-04	06127-14	121.8	06112-04	21	-01x1 -10x2
TTX NE06	112.3	06126-06	138.7	142.4	-06	06127-06	151.8	06112-06	0	-
TTX NH06	112.3	06226-06	138.7	142.4	-06	06232-06	151.8	06232-06	0	-
TTX NE08	142.3	06126-08	168.7	172.4	-08	06127-08	181.8	06112-08	0	-
TTX NH08	142.3	06226-08	168.7	172.4	-08	06232-08	181.8	06232-08	0	-

Figure 20.7

Table 2 with TTX 40 damper unit information. Dimensions in millimetre.

A	Top eye	B	Outer tube	D	I	Inner tube	External shaft	E	Internal shaft	F	External spacer	G	Internal spacer	H	End eye
53.3	06126-01 1)	76.7	06109-01	80.4	60.2	06110-01 3)	06127-01 1)	89.8	06112-01 1)	1	06130-01 1)	1	06132-01 1)	31.4	06136-01
58.3	06126-02 1)	84.7	06109-02	88.4	68.2	06110-02 3)	06127-02 1)	97.8	06112-02 1)	2	06130-02 1)	2	06132-02 1)	40.4	06136-02
70.3	06126-03 1)	96.7	06109-03	100.4	80.2	06110-03 3)	06127-03 1)	109.8	06112-03 1)	5	06130-05 1)	5	06132-05 1)	49.4	06136-03
82.3	06126-04 1)	108.7	06109-04	103.4	92.2	06110-04 3)	06127-12 1)	121.8	06112-04 1)	10	06130-10 1)	10	06132-10 1)	58.4	06136-04
112.3	06126-06 1)	138.7	06109-06	112.4	122.2	06110-06 3)	06127-04 1)	151.8	06112-06 1)	1	06233-01 2)	2	06242-02 2)	67.4	06136-05
112.3	06226-06 2)	168.7	06109-08	133.4	152.2	06110-08 3)	06127-14 1)	151.8	06232-06 2*)	2	06233-02 2)	5	06242-05 2)	76.4	06136-06
142.3	06126-08 1)			142.4	60.2	06290-01 4)	06127-06 1)	181.8	06112-08 1)	5	06233-05 2)	10	06242-10 2)	85.4	06136-07
142.3	06226-08 2)			142.4	68.2	06290-02 4)	06250-06 2)	181.8	06232-08 2*)	10	06233-10 2)			31.4	06219-01
				172.4	80.2	06290-03 4)	06127-08 1)							40.4	06219-02
				172.4	92.2	06290-04 4)	06250-08 2)							49.4	06219-03
					122.2	06290-06 4)								58.4	06219-04
					152.2	06290-08 4)								67.4	06219-05
														76.4	06219-06
														85.4	06219-07

Figure 20.8

Table of the different lengths available of the parts in the formulas.

- 1) For dampers with 12 mm piston shaft.
- 2) For dampers with 14 mm piston shaft.
- 3) Steel inner tube
- 4) Aluminium inner tube

20 - Damper Dimensions

Interchange Loc. M48.1.5-446h.

Outer diameter:
Upper: 56.000
Lower: 57.764
Middle diameter:
Upper: 57.006
Lower: 56.996
Inner diameter:
Upper: 56.268
Lower: 56.077

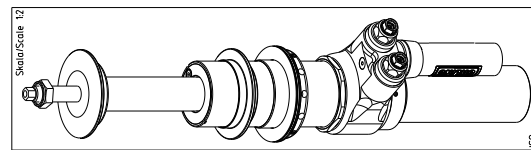
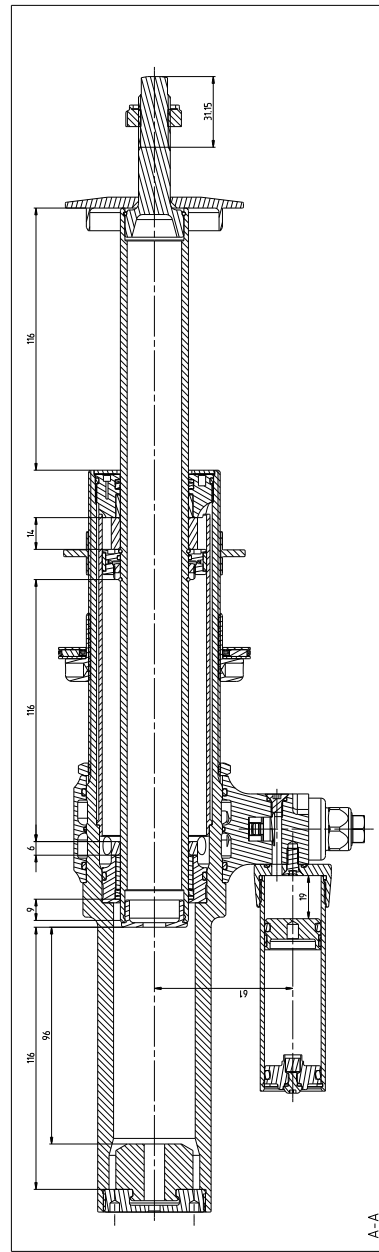
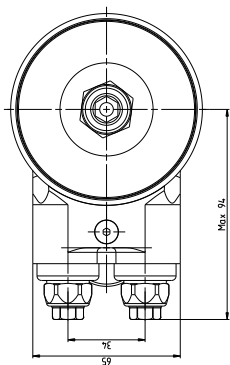
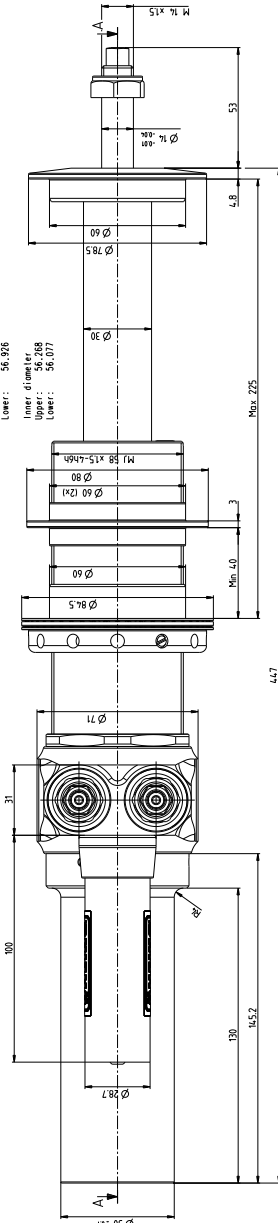

Part Number	1200
Part Name	TTX 4.6MT MkII
Part Description	Universal
Part Category	TTX N116
Part Code	08-02-19
Part Code	TK
Part Code	A1 13
Part Code	1200
Part Code	TTX N116

Part Number	59	1200	1200
Part Name	TTX 4.6MT MkII	Universal	TTX N116
Part Description	Universal	TTX N116	TTX N116
Part Category	TTX N116	TTX N116	TTX N116
Part Code	08-02-19	TK	A1 13
Part Code	1200	1200	1200
Part Code	TTX N116	TTX N116	TTX N116

20 - Damper Dimensions

This document must not be copied without our written permission, and the contents thereof must not be imparted to a third party nor be used for any unauthorized purpose. Contravention will be prosecuted.

Denna ritning är vår egendom och skyddad enligt gällande lag samt får ej utan vårt medgivande kopieras, delgivas annan eller obehörigen användas.

ISO-Toleranser
ISO-Tolerances

Ytjämnhet Ra/
Surface
roughness Ra

För ej tolerans-
satta mått
gäller för meas-
urements without
tolerances
applies
SS-ISO 2768-01m

Basmått (mm)	Tol (mm)
- 6	± 01
(6)- 30	± 02
(30)- 120	± 03
(120)- 400	± 05
(400)-1000	± 08

Rev.	Ändringens art/Type of change	Sign.	Datum/Date	Äm./Rev. nr

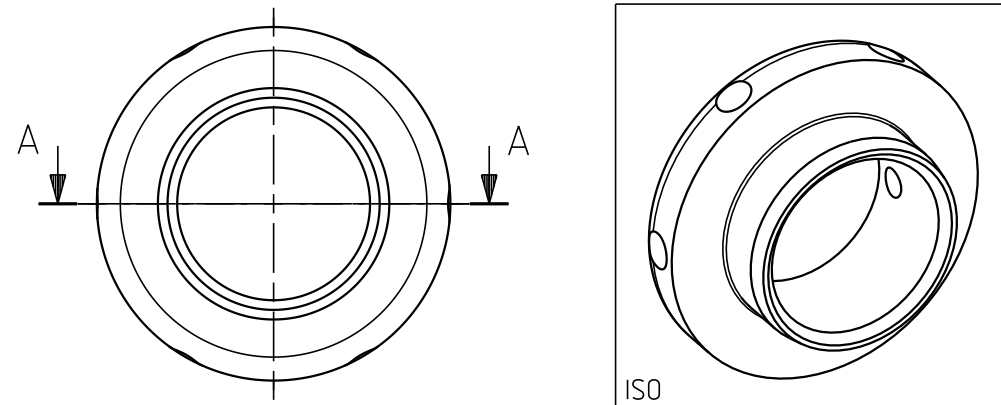

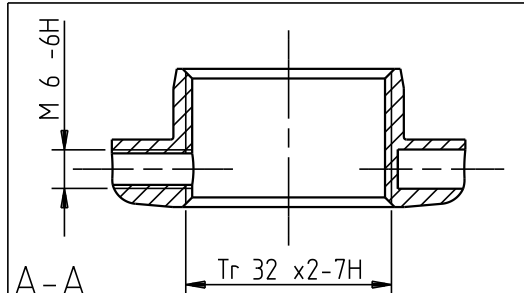

Material Aluminium EN-AW-6082 T6		Värmebehandling / Heat treatment		Ytbehandling / Surface treatment	
Datum / Date 08-02-18	Ritad / Drawn TK	Godkänd / Approved	Format-Skala / Scale A4 1:1	Lösa grader för ej förekomma / No loose burrs allowed	Jämför / Compare 3100
Benämning / Designation Spring retainer (05441)				Ritning nr / Drawing number (05441)	
				Revision -	



Spring retainer (05441)

(05441)

-

20 - Damper Dimensions

This document must not be copied without our written permission, and the contents thereof must not be imparted to a third party nor be used for any unauthorized purpose. Contravention will be prosecuted.

Denna ritning är vår egendom och skyddad enligt gällande lag samt får ej utan vårt medgivande kopieras, delgas annan eller obehörigen användas.

ISO-Toleranser
ISO-Tolerances

Ytjämnhet Ra/
Surface
roughness Ra

För ej toleranssatta mått
gäller för mätningar utan
toleranser
applies
SS-ISO 2768-01m

Basmått (mm)	Tol (mm)
- 6	± 01
6- 30	± 02
30- 120	± 03
120- 400	± 05
400-1000	± 08

Rev.	Ändringens art/Type of change	Sign.	Datum/Date	Äm./Rev. nr

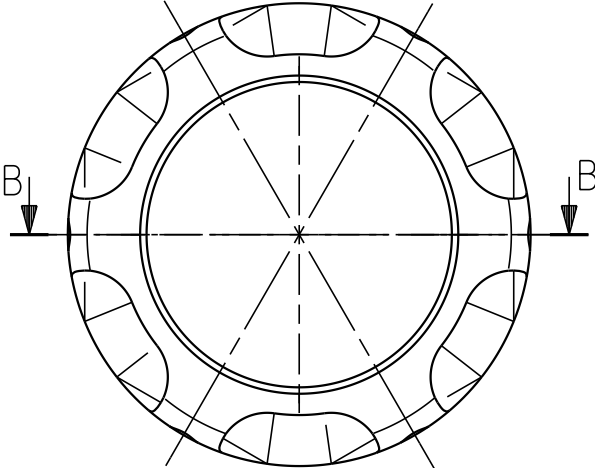

Scale 1:2

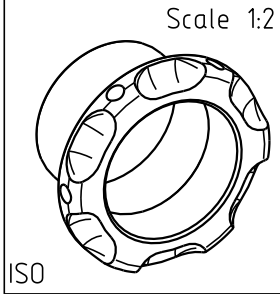

ISO

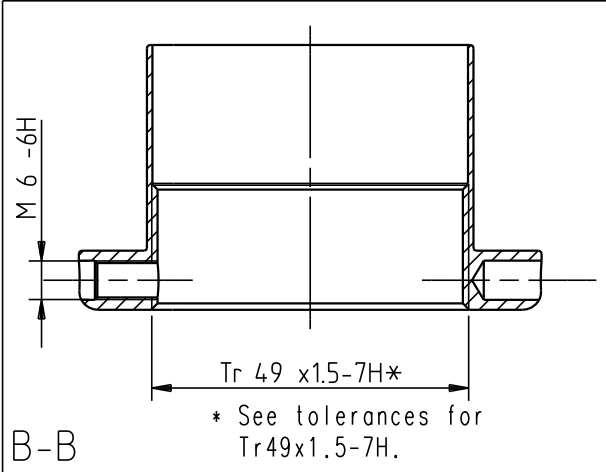

B-B

* See tolerances for Tr49x1.5-7H.

Tolerances for Tr49x1.5-7H.

Outer diameter
Lower: 49.3

Middle diameter
Upper: 48.474
Lower: 48.25

Inner diameter
Upper: 47.69
Lower: 47.5

Material		Värmebehandling / Heat treatment		Ytbehandling / Surface treatment	
Datum / Date 08-02-18		Ritad / Drawn TK	Godkänd / Approved	Format-Skala / Scale A4 1:1	Lösen grader för ej förekomma / No loose burrs allowed
Jämför / Compare			Artikelkod / Parts code 3100		
Benämning / Designation Spring platform (05964)				Ritning nr / Drawing number (05964)	
				Revision —	



20 - Damper Dimensions

This document must not be copied without our written permission, and the contents thereof must not be imparted to a third party nor be used for any unauthorized purpose. Contravention will be prosecuted.

Denna ritning är vår egendom och skyddad enligt gällande lag samt får ej utan vårt medgivande kopieras, delgas annan eller obehörigen användas.

ISO-Toleranser
ISO-Tolerances

Ytjämnhet Ra/
Surface
roughness Ra

För ej tolerans-
satta mått
gäller för meas-
urements without
tolerances
applies
SS-ISO 2768-01m

Basmått (mm)	Tol (mm)
- 6	± 01
6- 30	± 02
30- 120	± 03
120- 400	± 05
400-1000	± 08

Rev.	Ändringens art/Type of change	Sign.	Datum/Date	Äm./Rev. nr

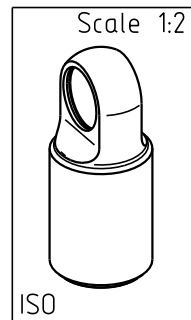
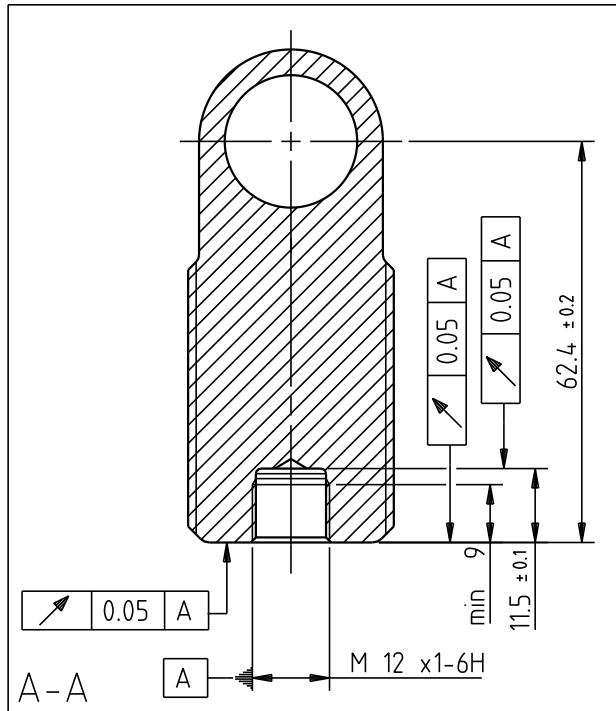
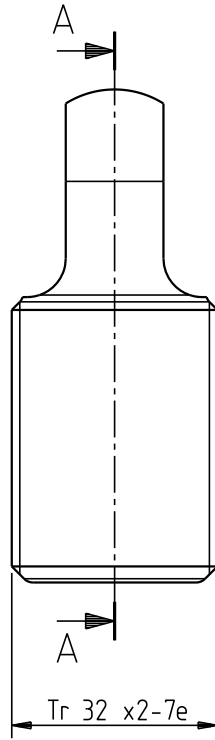

Material		Värmebehandling / Heat treatment		Ytbehandling / Surface treatment	

Datum / Date	Ritad / Drawn	Godkänd / Approved	Format-Skala / Scale	Lösa grader för ej förekomma / No loose burrs allowed	Jämför / Compare	Artikelkod / Parts code
08-02-18	TK		A4 1:1			2800

	Benämning / Designation	Ritning nr / Drawing number		Revision
		End eye (06133)		

20 - Damper Dimensions

This document must not be copied without our written permission, and the contents thereof must not be imparted to a third party nor be used for any unauthorized purpose. Contravention will be prosecuted.

Denna ritning är vår egendom och skyddad enligt gällande lag samt för ej utan vårt medgivande kopieras, delgivs annan eller obehörigen användas.

ISO-Toleranser
ISO-Tolerances

Ytjämnhet Ra/
Surface
roughness Ra

För ej tolerans-
satta mått
gäller för meas-
urements without
tolerances
applies
SS-ISO 2768-01m

Basmått (mm)	Tol (mm)
- 6	± 01
(6)- 30	± 02
(30)- 120	± 03
(120)- 400	± 05
(400)-1000	± 08

Rev.	Ändringens art/Type of change	Sign.	Datum/Date	Äm./Rev. nr

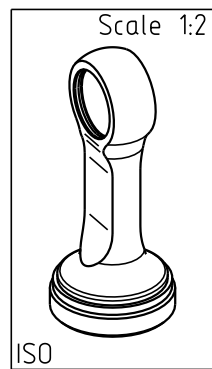
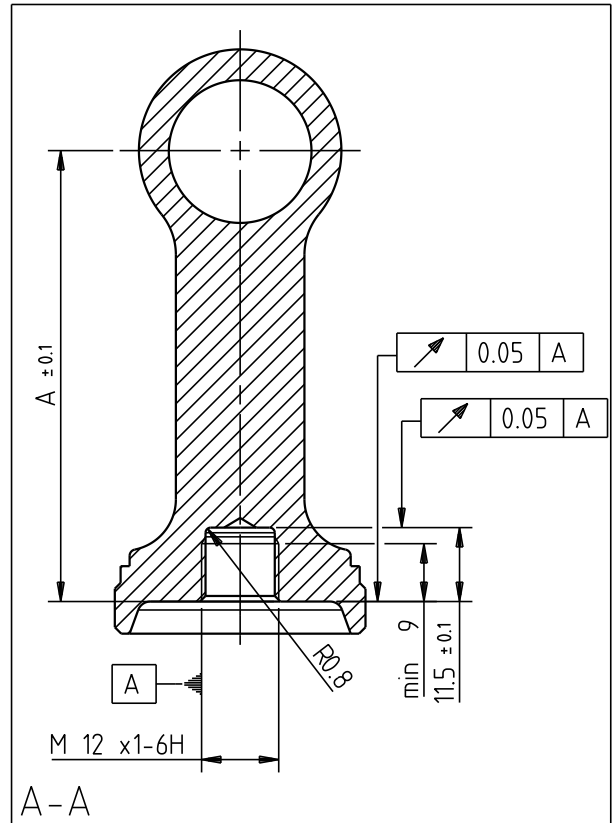
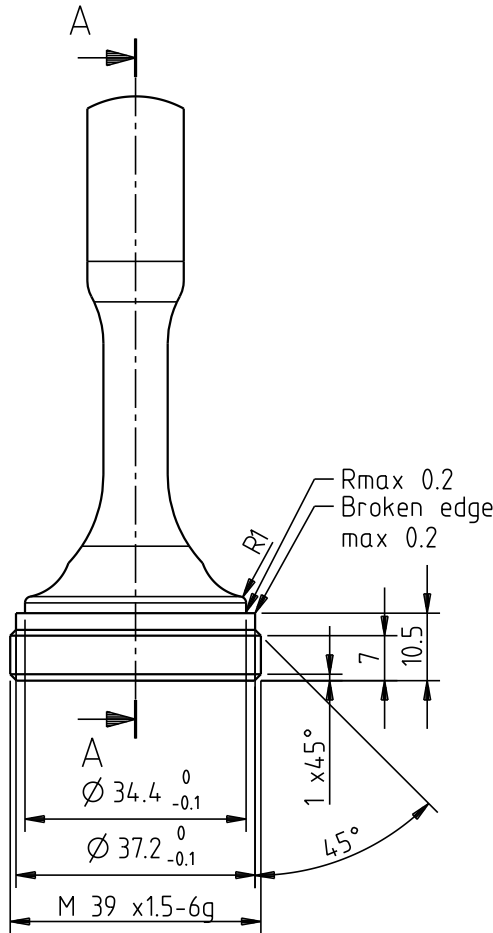

85.4	06136-07
76.4	06136-06
67.4	06136-05
58.4	06136-04
49.4	06136-03
40.4	06136-02
31.4	06136-01
A	Part no.

Material		Värmebehandling / Heat treatment		Ytbehandling / Surface treatment	

Datum / Date	Ritad / Drawn	Godkänd / Approved	Format-Skala / Scale	Lösa grader för ej förekomma / No loose burrs allowed	Jämför / Compare	Artikelkod / Parts code
08-02-18	TK		A4 1:1			2800

Benämning / Designation		Ritning nr / Drawing number	Revision
 End eye (06136-xx)		(06136)	-

20 - Damper Dimensions

This document must not be copied without our written permission, and the contents thereof must not be imparted to a third party nor be used for any unauthorized purpose. Infravention will be prosecuted.

Denna ritning är vår egendom och skyddad enligt gällande lag samt får ej utan vårt medgivande kopieras, delgas annan eller obehörigen användas.

ISO-Toleranser
ISO-Tolerances

Ytjämnhet Ra/
Surface
roughness Ra

För ej toleranssatta mått
gäller för mätningar utan
toleranser
applies
SS-ISO 2768-01m

Basmått (mm)	Tol (mm)
- 6	± 01
6- 30	± 02
30- 120	± 03
120- 400	± 05
400-1000	± 08



Rev.	Ändringens art/Type of change	Sign.	Datum/Date	Äm./Rev. nr

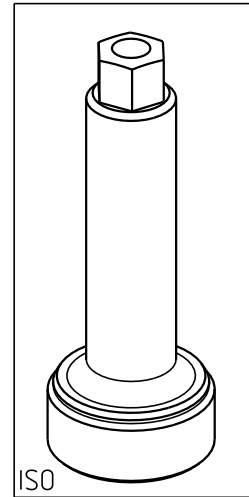
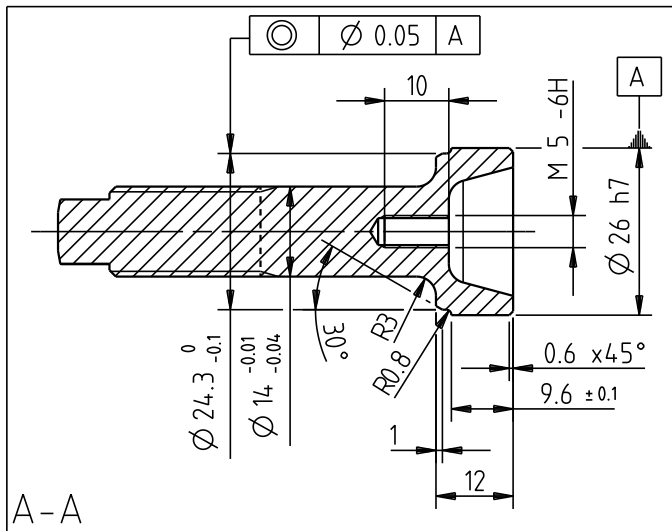
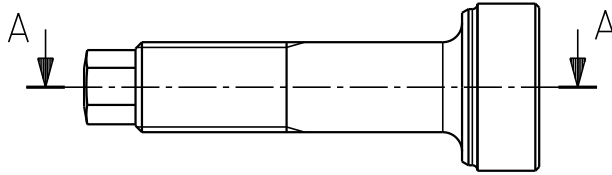

Material		Värmebehandling / Heat treatment		Ytbehandling / Surface treatment	
Datum / Date 08-02-18		Ritad / Drawn TK	Godkänd / Approved	Formal-Skala / Scale A4 1:1	Lösa grader för ej förekomma / No loose burrs allowed
Jämför / Compare		Artikelkod / Parts code 2800		Ritning nr / Drawing number (06210-01/02)	
Benämning / Designation ÖHLINS Shaft end		Revision		—	

20 - Damper Dimensions

This document must not be copied without our written permission, and the contents thereof must not be imparted to a third party nor be used for any unauthorized purpose. Infravention will be prosecuted.

Den här ritning är vår egendom och skyddad enligt gällande lag samt får ej utan vårt medgivande kopieras, delgas annan eller obehörigen användas.

Rev.	Ändringens art/Type of change	Sign.	Datum/Date	Äm./Rev. nr

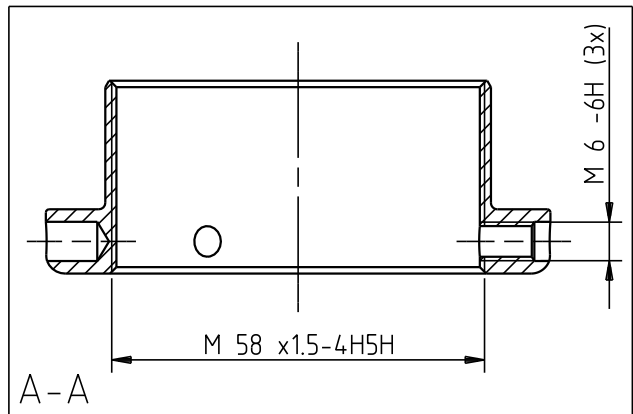
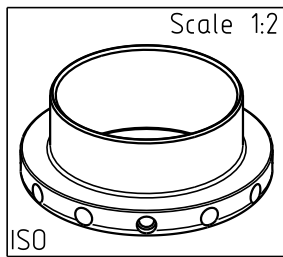
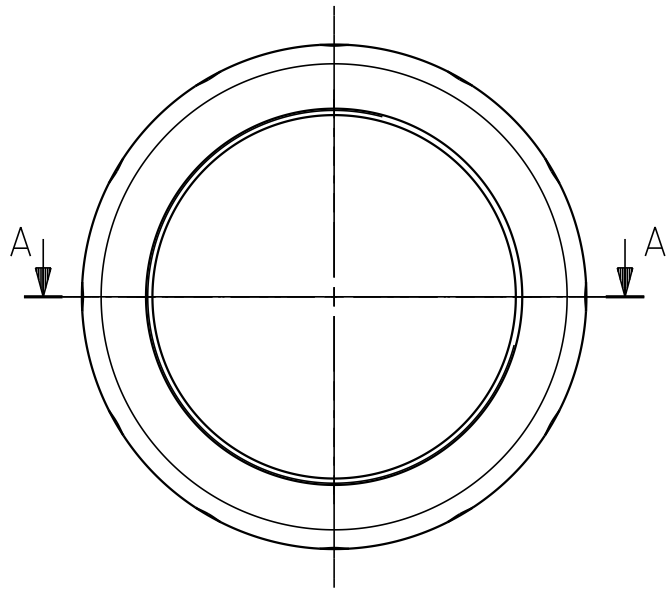

Tolerances for MJ58x1.5-4H5H

Outer diameter
Upper: 58.349
Lower: 58.000

Middle diameter
Upper: 57.158
Lower: 57.026

Inner diameter
Upper: 56.775
Lower: 56.539

ISO-Toleranser
ISO-Tolerances

Ytjämnhet Ra/
Surface
roughness Ra

För ej tolerans-
satta mått
gäller för meas-
urements without
tolerances
applies
SS-ISO 2768-01m

Basmått (mm)	Tol (mm)
- 6	± 01
6- 30	± 02
30- 120	± 03
120- 400	± 05
400-1000	± 08

Material		Värmebehandling / Heat treatment		Ytbehandling / Surface treatment	
----------	--	----------------------------------	--	----------------------------------	--

Datum / Date 08-02-18	Ritad / Drawn TK	Godkänd / Approved	Format-Skala / Scale A4 1:1	Lösa grader för ej förekomma / No loose burrs allowed	Jämför / Compare	Artikelkod / Parts code 3100
--------------------------	---------------------	--------------------	--------------------------------	---	------------------	---------------------------------



Benämning / Designation

Spring seat

Ritning nr / Drawing number

(06212-02)

Revision

—

20 - Damper Dimensions

This document must not be copied without our written permission, and the contents thereof must not be imparted to a third party nor be used for any unauthorized purpose. Contravention will be prosecuted.

Denna ritning är vår egendom och skyddad enligt gällande lag samt får ej utan vårt medgivande kopieras, delgivas annan eller obehörigen användas.

ISO-Toleranser
ISO-Tolerances

Ytjämnhet Ra/
Surface
roughness Ra

För ej tolerans-
satta mått
gäller för meas-
urements without
tolerances
applies
SS-ISO 2768-01m

Basmått (mm)	Tol (mm)
- 6	± 01
(6)- 30	± 02
(30)- 120	± 03
(120)- 400	± 05
(400)-1000	± 08

Rev.	Ändringens art/Type of change	Sign.	Datum/Date	Äm./Rev. nr

Botten radie max
0.4 (2x2x)./
Bottom radii max
0.4 (2x2x).
R4 (2x)
R0.85
Ø 38.7 ± 0.1
Ø 40.4 ⁰/_{-0.1}
3 (2x)
4
8
C
Ø 39
R2
A

15
1.85 (2x)
0.05 A
0.05 A
max Ø 5
70°
90°
R0.8
R2
M 12 x 1-6H
Ø 12.5 ¹
Ø 34.4 ± 0.1
Min 9 gängdjup/thread depth
11.5 ± 0.1
5
A-A

40	106,15	85,4	06219-07
31	97,15	76,4	06219-06
22	88,15	67,4	06219-05
5	79,15	58,4	06219-04
5	70,15	49,4	06219-03
5	61,15	40,4	06219-02
1	52,15	31,4	06219-01
C	B	A	Art nr./part no.

Material		Värmebehandling / Heat treatment		Ytbehandling / Surface treatment		
Datum / Date	Ritad / Drawn	Godkänd / Approved	Format/Skala / Scale	Lösa grader får ej förekomma / No loose burrs allowed	Jämför / Compare	
08-04-10	TK		A4 11		Artikelnr / Part's code 2800	
Benämning / Designation				Ritning nr / Drawing number		
 ÄNDÖGLA End eye				(06219)		Revision
						A

20 - Damper Dimensions

This document must not be copied without our written permission, and the contents thereof must not be imparted to a third party nor be used for any unauthorized purpose. Infravention will be prosecuted.

Den här ritning är vår egendom och skyddad enligt gällande lag samt får ej utan vårt medgivande kopieras, delgas annan eller obehörigen användas.

ISO-Toleranser
ISO-Tolerances

Ytjämnhet Ra/
Surface
roughness Ra

För ej tolerans-
satta mått
gäller för meas-
urements without
tolerances
applies
SS-ISO 2768-01m

Basmått (mm)	Tol (mm)
- 6	± 01
6- 30	± 02
30- 120	± 03
120- 400	± 05
400-1000	± 08

Rev.	Ändringens art/Type of change	Sign.	Datum/Date	Äm./Rev. nr

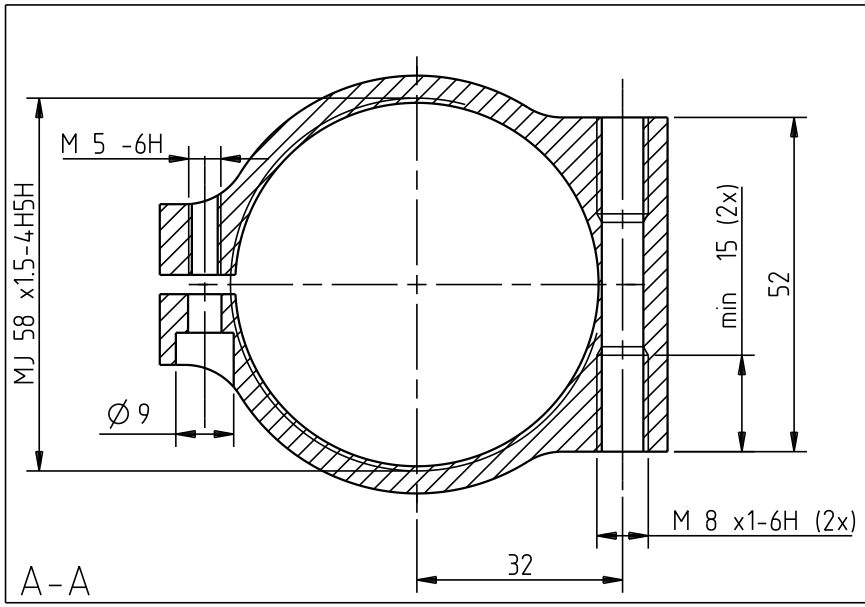
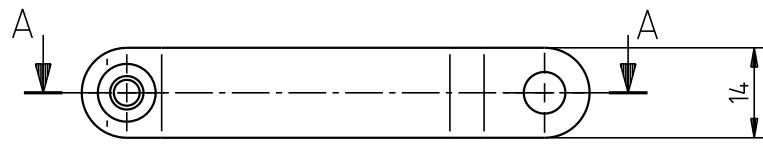

Tolerances for MJ58x1.5-4H5H

Outer diameter
Upper: 58.349
Lower: 58.000

Middle diameter
Upper: 57.158
Lower: 57.026

Inner diameter
Upper: 56.775
Lower: 56.539

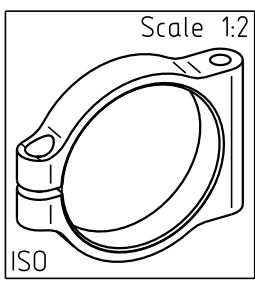

Material		Värmebehandling / Heat treatment		Ytbehandling / Surface treatment	
----------	--	----------------------------------	--	----------------------------------	--

Datum / Date 08-02-18	Ritad / Drawn TK	Godkänd / Approved	Format-Skala / Scale A4 1:1	Lösa grader för ej förekomma / No loose burrs allowed	Jämför / Compare	Artikelkod / Parts code 4400
--------------------------	---------------------	--------------------	--------------------------------	---	------------------	---------------------------------

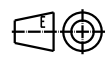

Sway-bar bracket

Ritning nr / Drawing number (06222-02)	Revision —
---	---------------

20 - Damper Dimensions

This document must not be copied without our written permission, and the contents thereof must not be imparted to a third party nor be used for any unauthorized purpose. Contravention will be prosecuted.

Denna ritning är vår egendom och skyddad enligt gällande lag samt får ej utan vårt medgivande kopieras, delgivas annan eller obehörigen användas.

ISO-Toleranser
ISO-Tolerances

Ytjämnhet Ra/
Surface
roughness Ra

För ej tolerans-
satta mått
gäller för meas-
urements without
tolerances
applies
SS-ISO 2768-01m

Basmått (mm)	Tol (mm)
- 6	± 01
(6)- 30	± 02
(30)- 120	± 03
(120)- 400	± 05
(400)-1000	± 08

Rev.	Ändringens art/Type of change	Sign.	Datum/Date	Äm./Rev. nr

A - A

Scale 1:1

ISO

Material		Värmebehandling / Heat treatment		Ytbehandling / Surface treatment	
Datum / Date	Ritad / Drawn	Godkänd / Approved	Format-Skala / Scale	Lösa grader för ej förekomma / No loose burrs allowed	Jämför / Compare
08-02-18	TK		A4 2:1		4000
Benämning / Designation				Ritning nr / Drawing number	
 Spacer				(06223-01)	
				Revison	
				-	

20 - Damper Dimensions

This document must not be copied without our written permission, and the contents thereof must not be imparted to a third party nor be used for any unauthorized purpose. Contravention will be prosecuted.

Denna ritning är vår egendom och skyddad enligt gällande lag samt får ej utan vårt medgivande kopieras, delgas annan eller obehörigen användas.

ISO-Toleranser
ISO-Tolerances

Ytjämnhet Ra/
Surface
roughness Ra

För ej tolerans-
satta mått
gäller för meas-
urements without
tolerances
applies
SS-ISO 2768-01m

Basmått (mm)	Tol (mm)
- 6	± 01
6- 30	± 02
30- 120	± 03
120- 400	± 05
400-1000	± 08



Rev.	Ändringens art/Type of change	Sign.	Datum/Date	Äm./Rev. nr

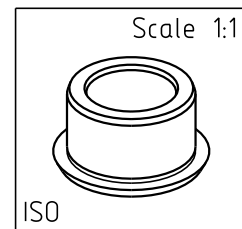
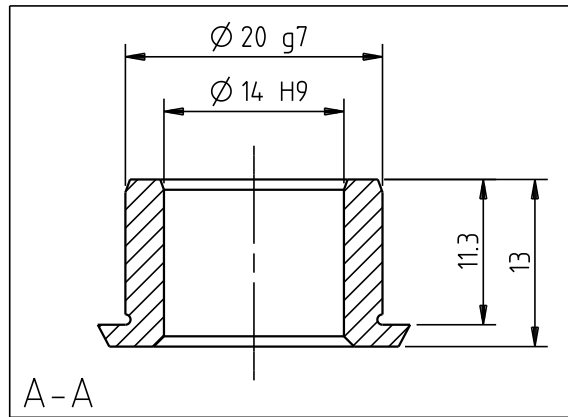
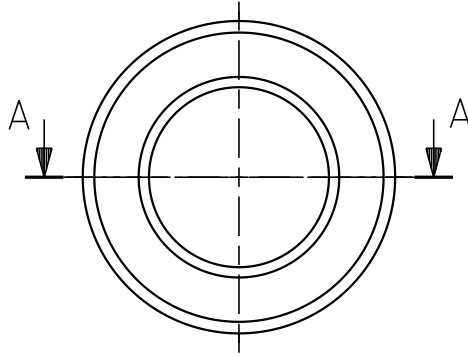

Material		Värmebehandling / Heat treatment			Ytbehandling / Surface treatment	
Datum / Date	Ritad / Drawn	Godkänd / Approved	Format-Skala / Scale	Lösa grader för ej förekomma / No loose burrs allowed	Jämför / Compare	Artikelkod / Parts code
08-02-18	TK		A4 2:1			4.000
Benämning / Designation					Ritning nr / Drawing number	
 Spacer					(06223-02)	
					Revision	
					-	

21 - Damper Identification

All Öhlins dampers are marked with the damper part number and the production order number. On the TTX40/TTX46 MT damper, these numbers are placed on the side of the cylinder head/valve housing.

The marked part number has one digit added to the number. This digit signifies the revision number.

Keep in mind that as some of the customers rebuild dampers themselves, the hardware configuration can be changed from the time when the damper was produced. As a result these part numbers are not a definite indication of the installed hardware on that particular damper.

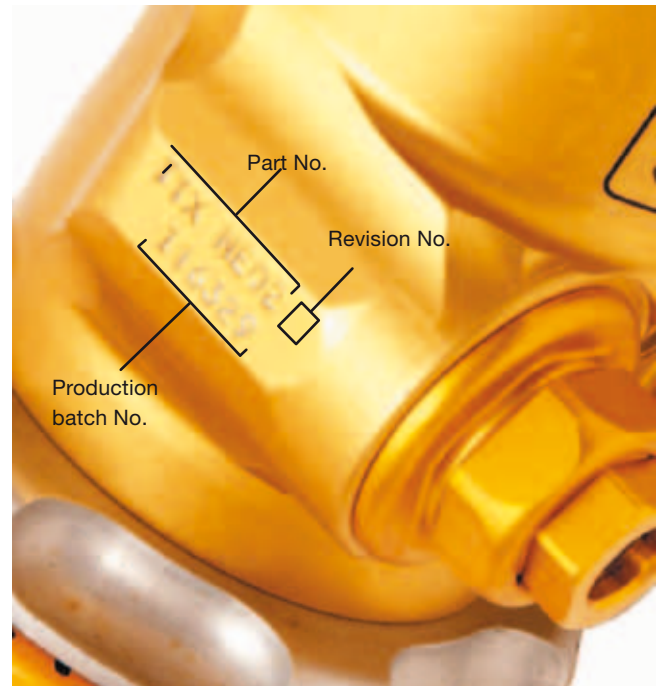

Figure 21.1
Damper identification.

22 - Technical Data

	Stroke [mm]	Length* [mm]	Weight [g]**
TTX NE01	48	207.6	810
TTX NH01	48	207.6	780
TTX NE02	56	243.6	880
TTX NH02	56	243.6	845
TTX NE03	68	264.6	910
TTX NH03	68	264.6	855
TTX NE04	80	321.6	1025
TTX NH04	80	321.6	980
TTX NE06	110	390.6	1145
TTX NH06	100	390.6	1165
TTX NE08	140	480.6	1345
TTX NH08	130	480.6	1320
TTX NH16	116	447	2310
TTX NI16	116	447	2310

External adjusters 4
 Number of click positions:
 Low Speed Compression 40
 High Speed Compression 50
 Low Speed Rebound 40
 High Speed Rebound 50
 Max recommended velocity 1.5 m/s (60 inch/sec.)
 Max damping peak force 8000 N (1800 lbs.)
 Max bump rubber force 8000 N (1800 lbs.)
 Max operating temperature 120°C (approx. 250°F)
 Oil Öhlins damper fluid 309
 Recommended gas pressure 5 bar (75 psi)

TTX40

The length is measured from the spherical bearing centre of the top eye to where the lock nut on the piston rod sits against the end eye. By adding the given length of the end eye in chapter *Damper dimensions* you get the total length centre to centre of the bearings.

TTX46 MT

The length is measured from the bottom of the tube to the top surface of the spring seat. See chapter *Damper dimensions* for more info.

** Weight is measured without spring seats, end eyes and springs.

23 - Optional Parts

There are some optional Öhlins parts available for the TTX40 and TTX46MT dampers. These parts are not always specifically made for the TTX40/46MT dampers and can be used together with different Öhlins products. These parts have to be bought separately

Bump rubbers

Bump rubbers are used both as spring elements, very often in combination with coil springs or torsion springs to achieve increased resistance to compress the damper further into the stroke.

The bump rubbers are normally engaged only when the damper is compressed some distance from static ride height position. If the bump rubber is used only when the damper is almost fully compressed to prevent the damper from bottoming metal to metal, the rubber is used more as a bump stop.

However, very often, the bump rubber is an active part of the suspension. In particular, in applications with a lot of downforce. The force produced by bump rubbers is largely position dependent, but compared to steel coil springs, there is also quite a bit of damping, "hysteresis", from the bump rubbers. Increased frequency (velocity) at given amplitude will increase the force produced both under the loading and the unloading phase.

The hysteresis will also increase. Because of this and the non-linearity when engaging the bump rubber, simulations including bump rubbers are quite complicated without simplifications.

Bump rubbers are just as the name indicates made out of rubber. Öhlins mainly uses bump rubbers made out of polyurethane, a material made with small closed cells filled with gas. Different densities are used to produce varying spring rates.

The spring rate always increases when the rubber is compressed. By making bump rubbers with different shapes, different characteristics can be achieved.

Öhlins has many different bump rubbers available, these bump rubbers are:

Part no.	Shaft diameter	Height	Colour	Density
05375-15	12 mm	10 mm	Black	550±50 g/cm ³
05375-16	12 mm	10 mm	Nature	650±50 g/cm ³
06375-01	14 mm	10 mm	Black	550±50 g/cm ³
06375-02	14 mm	20 mm	Black	550±50 g/cm ³
06375-03	14 mm	30 mm	Black	550±50 g/cm ³

To increase the number of combinations some of these bump rubbers are made short, so you can achieve different characteristics by stacking them differently. This is done by changing the number and type of rubber and also by playing with separately plastic washers. Adding a separating washer between two rubbers will increase the stiffness slightly. Below you can find some examples of how the force changes due to displacement.

Always use a plastic washer of type 06130-XX (12 mm shaft) or 06233-XX (14 mm shaft) between the rubber and the cylinder cap (part no. 06114-01 or 06251-01) to avoid damaging the bump rubber by the holes of the cylinder cap. The thinnest washer 06130-01 or 06233-01 (1 mm) is enough to handle the loads of the rubber.

Spacer (always keep a spacer on top of the stack)

Bump rubber

Spacer

Bump rubber

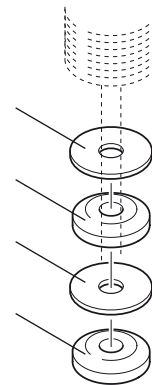
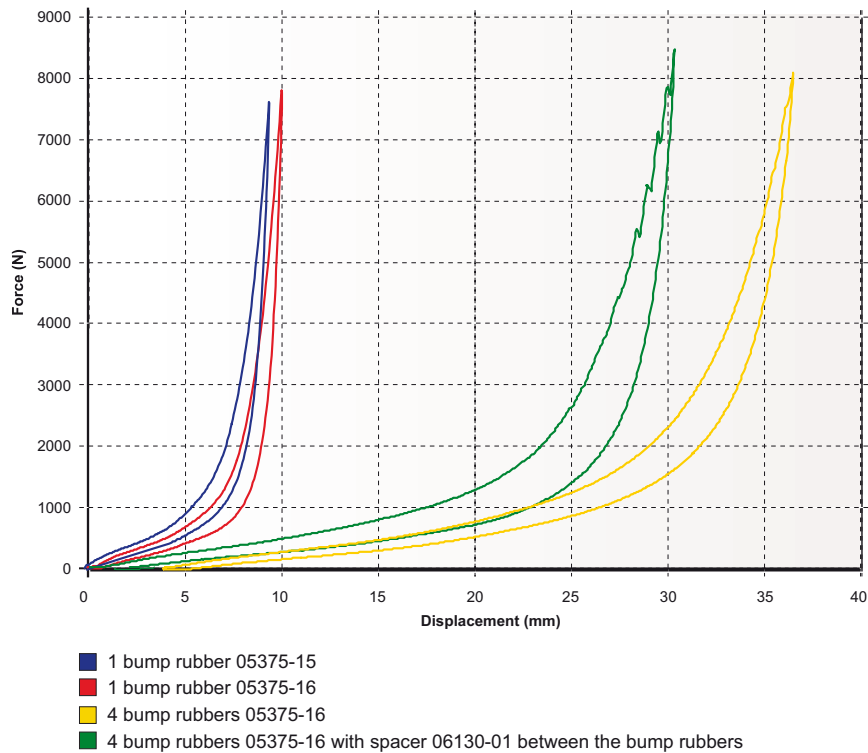

Figure 23.1 Example of a bump rubber stack.

Figure 23.2

Examples of different bump rubber stiffness. The measurement took place at low frequency.



The maximum load to use from bump rubbers on the TTX40 damper is 8000 N (approx. 1800 lbs). For information about the specific bump rubbers, please contact an Öhlins distributor.

Weight jacker 05490-01

Weight jackers are used to change the balance of the car by changing the position of one of the spring platforms. Often, the adjustment is made directly from the cockpit. Weight jackers are especially useful in oval racing.

For the TTX40 damper, Öhlins offers the hydraulic spring preloader (weight jacker) 05490-01. It consists of a master cylinder and a slave cylinder connected by a hose. By turning the adjuster wheel of the master cylinder, the piston of the slave cylinder will move.

The spring preloader is designed for 21/4 inch inner diameter (i.d.) springs and comes with a 1500 mm long hose.

The rate is 0.5 mm/turn and the stroke is 6.5 mm.

The spring preloader can be adjusted by hand to approx. 5500 N (1200 lbs) of load.

Maximum load to use is 11 000 N (2500 lbs).

By changing some parts in the master cylinder, the spring preloader can be rebuilt so you get a rate of 0.75 mm per turn. However, this will increase the torque needed for a specific load.

If the spring preloader needs to be taken apart for whatever reason, it is very important to get all the air out of the system when it is assembled. If not, the stroke will be reduced and flex in the system will increase. For the best result, use a vacuum filling machine. High loads on the spring preloader will compress the oil and the spring preloader, causing some flex in the system. At maximum load, the stroke of the slave cylinder can be expected to drop about 1 mm to 5.5 mm. For further information regarding Öhlins hydraulic spring preloader, please contact your Öhlins distributor.

There are some more Optional Parts available from Öhlins Racing, please see the Spare Parts Manual for your specific dampers for more information.



Öhlins Owner's Manual 07430-02_1 | Issued 2010-03-23 | © 2010 Öhlins Racing AB

Your Öhlins retailer:



Öhlins Racing AB
Box 722
SE-194 27, Upplands Väsby
Sweden

Phone: +46 (0)8 590 025 00
Fax: +46 (0)8 590 025 80
www.ohlins.com



www.ohlins.com