

Öhlins Front Fork Road & Track
FG 43

Owner's Manual



Öhlins Headquarters Upplands Väsby, Sweden

Öhlins Racing AB - The Story

It was the 1970's, a young man named Kenth Öhlin spent most of his spare time pursuing his favourite sport: motocross.

Being a careful observer, Kenth's attention was continuously drawn to one specific detail - motocross bikes had more engine power than their suspension could handle. It was not long before Kenth realised that better performance could be achieved by improved wheel suspension.

Öhlins Racing was established in 1976, and just two years later the company won its first World Championship title. Despite being in the business for 35 years, the search for perfection and new functions is still the main focus of the company.

Congratulations! You are now the owner of an Öhlins product. More than two hundred World Championships and other major world titles are definitive proof that Öhlins products offer outstanding performance and reliability.

Every product has gone through rigorous testing and engineers have spent thousands of hours, doing their very best to use every possible experience from our 35 years within the racing sport.

The product that you now have in your possession is pure racing breed that is built to withstand.

By installing this product on your vehicle you have made a clear statement... you are a serious rider or driver with a focus on getting the maximal handling ability and outstanding feedback from your vehicle. Along comes the fact that your Öhlins product will be a long lasting friend, delivering the very best of comfort and performance every time you go for a ride. Go explore!

SAFETY PRECAUTIONS

General Warnings

Note!

The shock absorber/front fork/steering damper is an important part of the vehicle and will affect the stability.

Note!

Read and ensure you understand the information in this manual and other technical documents provided by Öhlins, before using the product.

Note!

Öhlins Racing AB can not be held responsible for any damage to the shock absorber/front fork/steering damper, vehicle, other property or injury to persons, if the instructions for mounting, usage and maintenance are not followed exactly.

Warning!

After installing the Öhlins product, take a test ride at low speed to ensure your vehicle has maintained stability.

Warning!

If the suspension makes an abnormal noise, or the function is irregular, or if you notice any leakage from the product, stop the vehicle immediately and return the product to an Öhlins dealer.

Warning!

The product warranty shall only apply if the product has been operated and maintained in accordance with recommendations in this manual. If you have any questions regarding usage, service, inspection and/or maintenance please contact Öhlins.

Note!

When working with the Öhlins product, always read the vehicle service manual.

Note!

This manual shall be considered as a part of the product and shall accompany the product throughout its life cycle.

SAFETY SYMBOLS

In this manual, mounting instructions and other technical documents, important information concerning safety is distinguished by the following symbols:



The Safety Alert Symbol means: Warning! Your safety is involved.

Warning!

The Warning Symbol means: Failure to follow warning instructions can result in severe or fatal injury to anyone working with, inspecting or using the product, or to bystanders.

Caution!

The Caution Symbol means: Special precautions must be taken to avoid damage to the product

Note!

The Note Symbol indicates information that is important regarding procedures.

Product Specific Warnings

Warning!

This product was developed and designed exclusively for a specific vehicle model and shall only be installed on the intended vehicle model in its original condition as delivered from the vehicle manufacturer.



CONTENTS

1 Design.....	4
2 Adjusters	5
3 Setting up.....	6
4 Change spring.....	8
5 Oil level	9
6 Technical Information	10
7 Inspection and maintenance	11

1 DESIGN

Öhlins Front Fork FG43

The Öhlins front fork uses a cartridge system for damping. This gives a damping force which depends on the speed of the piston in the cartridge system. The combination of spring and air volume (oil level) offers a possibility to adjust the characteristics of the fork to suit different tracks and riders. For example, a soft spring in combination with a small air volume (high oil level)

gives progressive action of the front forks. For better understanding, please see the oil level chart later in this manual. A telescopic front fork depends on smooth friction free action. Make sure to service your front forks regularly. See chapter Inspection and maintenance later in this manual.

2 ADJUSTERS

Spring preload adjuster

Use a 17 mm wrench to turn the upper adjustment screw. Maximum adjustment range is 15 mm. One turn of the adjustment screw will cause 1 mm change in spring preload. Increase by turning clockwise, decrease by turning counter-clockwise.

Rebound damping adjuster

Use a hexagon screwdriver (00794-01) or a 3 mm Allen key. Adjustment range from fully closed valve (clockwise) to fully open valve (counter-clockwise) is about 20 clicks.

Compression damping adjuster

Use a 3 mm Allen key with a spherical head (tool 00794-01). Adjustment range from closed valve (clockwise) to maximum open valve (counter-clockwise) is 20 clicks.

Rebound and Compression

Recommended setup according to the Mounting Instructions. Normal adjustment range from original position is +/-4 clicks.

Caution!

When adjusting, turn carefully not to damage delicate sealing surfaces.

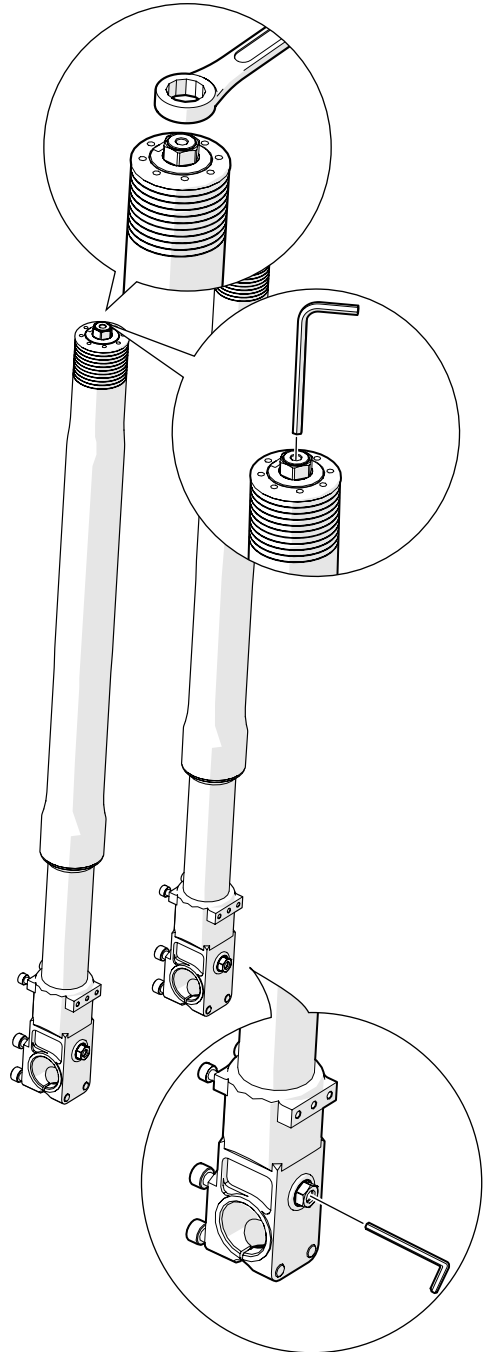

3 SETTING UP

Below you will find some basic guidelines for setting up your Öhlins front forks. However, you must remember that the front forks are just one part of your motorcycle and to get it to work properly, the whole motorcycle has to be set up according to the vehicle manual.

1
Put your bike on a front stand so you can install the front forks.

Maximum torque on the bottom triple clamp and steering damper bracket (if it is located on the diameter of the outer tube) is 15-18 Nm.
Remove the front wheel and brakes.

2
Unscrew the adjustment housing on top of the fork (use tool 00797-04) on both upper tubes. Slide the fork up and down gently to make sure everything works correctly.

3
Make sure the fork is fully extended. Assemble the adjustment housing again and set your initial preload of the spring by using a 17 mm wrench until you achieve a static sag of 25-30 mm.
Each turn gives 1 mm in preload.
Maximum preload: 15 mm

4
The clicks are a bleed function, separate for rebound and compression damping. Adjust rebound from the top centre of the fork and compression from the bottom part of the fork. Start to count from fully closed (clockwise) and set to the recommended number of clicks (use a 3 mm Allen key). For recommended setup see the Mounting Instructions or contact Öhlins.

⚠ Caution!

When adjusting, turn carefully not to damage delicate sealing surfaces.

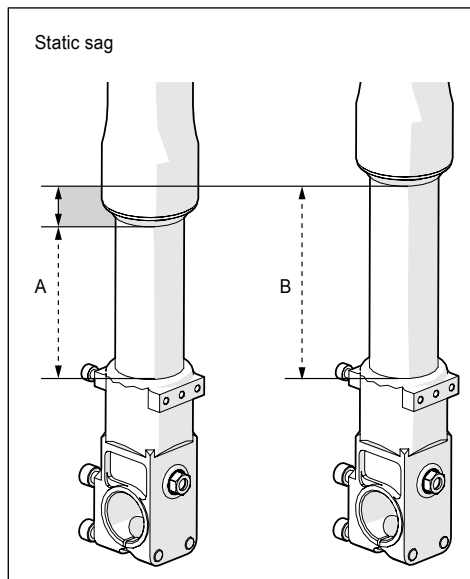

3 SETTING UP

Step 1 - Measure the sag

Spring preload is a crucial part of setting your motorcycle since it affects the height of the motorcycle and the fork angle. Measure the sag before setting the spring preload.

1. Make sure you are working on a flat surface. Put the motorcycle on a work stand so that both wheels are off the ground and the suspension is unloaded.
2. Mark, e.g. with a piece of tape, a point immediately above the rear wheel axle.
3. Measure the distance from the marked point to a fixed point, e.g. the wheel axle (R1).
4. Measure the distance from the bottom of the upper triple clamp to a fixed point, e.g. the front wheel axle (F1).
5. Put the motorcycle on the ground so that the front and the rear suspensions are slightly compressed. Repeat the measuring procedures (R2 and F2).
6. Sit on the motorcycle in normal riding position, properly outfitted in full riding gear. Repeat the measuring procedure (R3 and F3).

Recommended Measures

If no other recommendations are given in the Mounting Instructions follow these recommended measures:

Free sag

Rear (R1-R2)	10-20 mm
Front (F1-F2)	15-30 mm

Ride height

Rear (R1-R3)	25-40 mm
Front (F1-F3)	35-50 mm

👁 Note!

Always check on the Öhlins web site

www.ohlins.com or with your Öhlins dealer for latest updates.

Step 2

Adjust spring preload

1. If your sag measures differ significantly from the recommendations in the Mounting Instructions or the table, adjust the spring preload. (See chapter Spring Preload in this manual).
2. If the ride height still differs from the recommendations, you may need to change to softer/harder spring. Contact an Öhlins dealer for advice.

⚠ Warning!

Incorrect spring rate may result in a front geometry that is either too steep or too flat. This can result in a tendency of under or over steering, that could seriously affect the handling characteristics of the motorcycle.

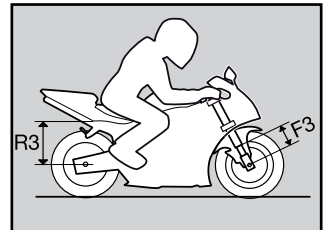
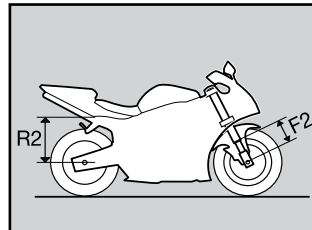
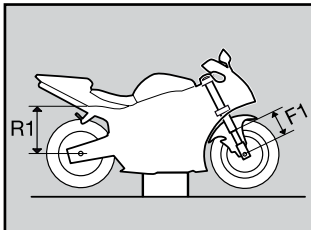

4 CHANGE SPRING

Service Tools

Description	Part no
Clamp tool	00786-05
Clamp tool	00787-03
Top nut tool	00797-04
Cartridge tool	04702-02
Top nut holder	04705-01

4.1

Loosen the screws that hold the fork legs in the upper triple clamps.

4.2

Loosen the top nut assembly approximately 2 turns, use top nut tool (00797-04).

4.3

Remove the fork legs from the motorcycle.

4.4

Put one fork leg in a vice with soft jaws.

4.5

Release the spring preload completely. Use a 17 mm wrench.

⚠ Caution!

Do not damage the O-ring. Carefully remove the adjustment housing.

4.6

Remove the adjustment driver, preload tube and the spring. Note the positions of the parts.

4.7

Pull out the piston rod as far as possible and turn the compression adjuster screw fully clockwise. This will keep the piston rod in top position which facilitates the installation procedure.

4.8

Install the new spring, adjustment driver and preload tube. Make sure to put all parts back in the same position as they were before the removal.

4.9

Reinstall the top nut assembly.

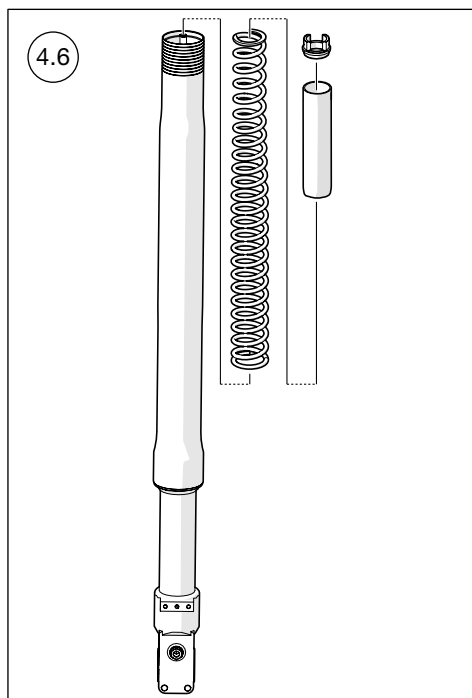
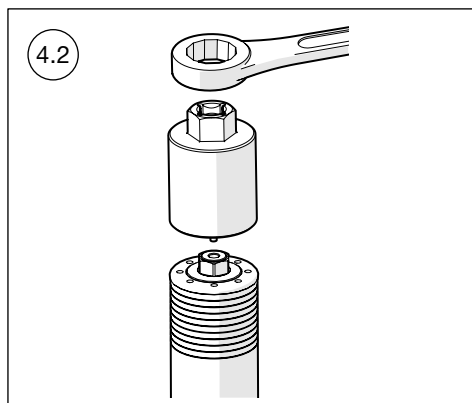

4 CHANGE SPRING

4.10

Fasten the adjustment housing in the fork leg.
Make sure that the fork leg is fully extended when tightening the adjustment housing.

4.11

Install the fork legs on the motorcycle and set the preload, compression and rebound according to recommended setup data in the Mounting Instructions or contact an Öhlins dealer for advice.

5 OIL LEVEL

Compared to conventional type of front forks, the upside down front forks are very sensitive to variations in oil level. Therefore, adjust the oil level with special care. A change in the fork oil level will not affect damping force in the early stage of fork travel, but will have a great effect in the later stage.

When the oil level is raised:

The air spring in the later half stage of travel is stronger, and thus the front forks harder.

When the oil level is lowered:

The air spring in the later half stage of travel is reduced thus the front forks are softer. The oil level works most effectively at the end of the fork travel. Air spring characteristics shown, refer to

a general card description to facilitate understanding of the difference when the oil level is changed.

👁 Note!

Adjust the oil level in mm according to the figure with the fork fully compressed and with the spring and the pre-load tube removed. For the right recommended level, please see the mounting instruction.

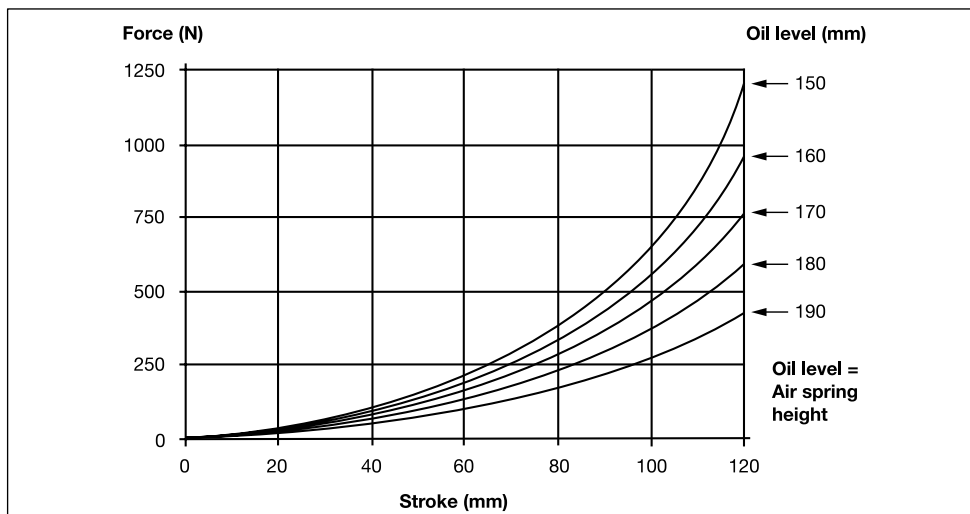
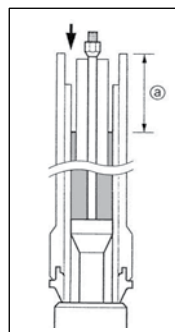

6 TECHNICAL INFORMATION

Fork length

See Mounting instructions

Stroke

See Mounting instructions

Free spring length

See Mounting instructions

Rebound adjustment

Basic setting 9-12 clicks

Maximum open valve 20 clicks

Compression adjustment

Basic setting 6-16 clicks

Maximum open valve 20 clicks

Spring preload adjustment

0-15 mm (0-15 turns)

Spring rate

See Mounting instructions.

Optional springs and rates:

Part no	Rate (N/mm)
08790-80	8.0
08790-85	8.5
08790-90	9.0
08790-95	9.5
08790-10	10.0
08790-05	10.5
08790-11	11.0
08790-15	11.5
08790-12	12,0
08790-13	13,0

Oil Level

Please see Mounting instructions for the specific front fork.

Caution!

Use only Öhlins high performance front fork fluid (1309-01).

Loctite glue

542 on Fork bottom thread

Tightening torque

Triple clamp bolt 15-18 Nm

Grease

Öhlins front fork grease 00146-01 (red grease).

7 INSPECTION AND MAINTENANCE

Preventive maintenance and regular inspection reduces the risk of functional disturbance. If there is any need for additional service, please contact an authorized Öhlins Service Centre.

Clean the front fork externally with a soft detergent. Use compressed air. Be careful that all dirt and debris is removed. Keep the front fork clean and always spray it with oil (QS 14, WD40 or CRC 5-56 or similar) after washing the vehicle.

⚠ Caution!

Never use detergents that can damage the surfaces of the front fork. Use of thinner and brake cleaner will dry the surfaces too much.

👁 Note!

Make certain that your front fork is always filled with Öhlins High Performance Front Fork Oil (1309-01).

Inspection points

1. Check the front fork for leakage.
2. Check the front fork tubes for external damages.
3. Check the attachment points of the caliper bracket and fender bracket.
4. Check the attachment points to the vehicle.

Inspection intervals

Normal use: Once a year or every 5000 km

Race track: Every ten hours

Once every 2nd year (or 20 000 km), general:

Change front fork oil,

👁 Note!

Use Öhlins Front fork oil (01309-01) only.

👁 Note!

Discarded Öhlins products should be handed over to an authorized work shop or distributor for proper disposal.

Inspection points

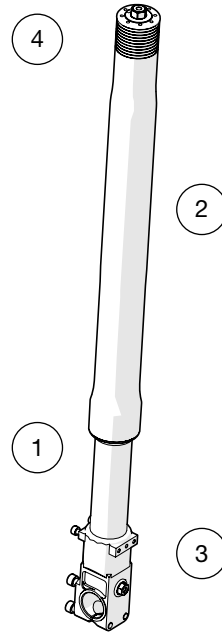



Owner's Manual | Part No. 07282-04_2 | Issued 2015-06-03 | © Öhlins Racing AB

Your Öhlins retailer:

Öhlins Racing AB
Box 722
SE-194 27, Upplands Väsby
Sweden

Phone: +46 (0)8 590 025 00
Fax: +46 (0)8 590 025 80
www.ohlins.com



www.ohlins.com