

7

Adjust the steering damper by letting it slide in its bracket assembly so the steering damper uses similar stroke lengths both ways.

**NOTE!**

*Make sure that there are no problems for clearance when turning the steering to the left and right end positions and that the damper not is used as a stop.*

9

Make a set-up of the damper to recommended click position.

**NOTE!**

*Make sure that all bolts are tightened to the correct torque and that nothing fouls or restricts movement of the steering damper when it is being fully compressed or extended.*

8

Tighten the bolts to correct torque (5 Nm).

10

Continue your work according to the Owners Manual, section Adjustments

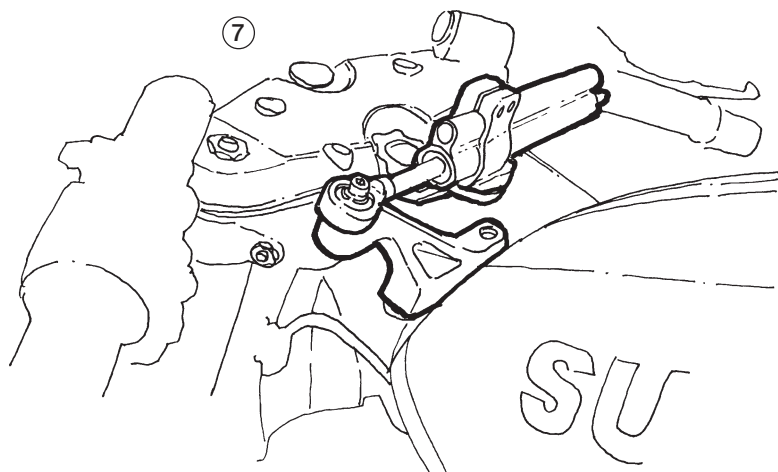

**Set-up data**

Recommended set-up 10 clicks from closed



Öhlins Racing AB, Box 722, S-194 27 Upplands Väsby, Sweden.  
Phone +46 8 590 025 00. Fax +46 8 590 025 80.  
[www.ohlins.com](http://www.ohlins.com)

Part No. SD 182. Issued 05 04 06

# Mounting Instructions

## Öhlins steering damper kit SD 182 for Suzuki Hayabusa



### Öhlins steering damper R&T

Your Öhlins steering damper R&T features the following adjuster:

The adjustment knob has 16 different positions and counts in number of clicks from maximum hard position.

**NOTE!**

*When delivered the Öhlins steering damper is dialed to recommended setting for the specific brand and make of the motorcycle. If you have changed the settings follow the instruction below:*

The adjusters have a normal right hand thread. Turn clockwise to fully closed (pos. zero [0]). Turn counter clockwise to open and count the clicks until you reach the recommended number of clicks. See Setup data at last page.

**CAUTION!**

*Do not use too much force, delicate sealing surfaces can be damaged. Use fingers only.*

Adjuster

© Öhlins Racing AB. All rights reserved. Any reprinting or unauthorized use without the written permission of Öhlins Racing AB is prohibited. Printed in Sweden.



## Safety signals

Important information concerning safety is distinguished in this manual by the following notations.



The Safety alert symbol means:  
Caution! Your safety is involved.

### ⚠ WARNING!

Failure to follow warning instructions could result in **severe or fatal injury** to anyone working with, inspecting or using the steering damper, or to bystanders.

### CAUTION!

Caution indicates that special precautions must be taken to avoid damage to the steering damper.

### NOTE!

This indicates information that is of importance with regard to procedures.

## Before you start

### ⚠ WARNING!

1. Installing a steering damper, that is not approved by the vehicle manufacturer, may affect the stability of your vehicle. Öhlins Racing AB cannot be held responsible for any personal injury or damage whatsoever that may occur after fitting the steering damper. Contact an Öhlins dealer or other qualified person for advice.

2. Please study and make certain that you fully understand all the mounting instructions and the owner's manuals before handling this steering damper kit. If you have any questions regarding proper installation procedures, contact an Öhlins dealer or other qualified person.

3. The vehicle service manual must be referred to when installing the Öhlins steering damper.

Öhlins Racing AB can not be held responsible for any damage whatsoever to steering damper or vehicle, or injury to persons, if the instructions for fitting and maintenance are not followed exactly. Similarly, the warranty will become null and void if the instructions are not adhered to.

### NOTE!

During storage and transportation, especially at high ambient temperature, the oil and grease used for assembling may run out inside the packing and damage the expanded polystyrene packing material. This is not unusual and is in no way detrimental to the steering damper.

Öhlins products are subject to continual improvement and development. Consequently, although these instructions include the most up-to-date information available at the time of printing, there may be minor differences between your steering damper and this manual. Please consult your Öhlins dealer if you have any questions with regard to the contents of the manual.

## Kit contents

Before installing the steering damper, please check the contents of the kit, listed on the front page of this instruction. If anything is missing, contact your Öhlins dealer.

Steering damper stroke 63	02260-10	1
Bracket assembly	02230-03	1
Frame bracket	02272-02	1
Bracket	02270-30	1
Sleeve	02239-01	2
Teflon spacer	02259-03	1
Bolt MC6Sx35	01046-06	2
Bolt MC6Sx25	01046-17	2
Nut M24x1.5	02273-02	1
Sticker Öhlins Racing AB	00192-01	2
Sticker	00194-10	2
Owners Manual	07261-01	1

© Öhlins Racing AB.  
All rights reserved.

Any reprinting or unauthorized use without the written permission of Öhlins Racing AB is prohibited.  
Printed in Sweden.

## Mounting Instructions

1

Put the motorcycle on a stand and make sure it's steadily fixed so it will not fall over.

### ⚠ WARNING!

1. It's advisable to have an Öhlins dealer or other qualified person to fit your steering damper.  
2. Instructions in the vehicle service manual are to be followed when changing the steering damper.

2

Loosen the the fuel tank attachment.

3

Fit the frame bracket so the longer part of the bracket should be pointing to the left side of the motorcycle. Use the supplied bolts (01046-06) to fix the fuel tank and the bracket.

4

Loosen the steering stem nut. Fit the bracket arm supplied. The bracket should be facing backwards, so it locks on the edge of the triple clamp. Lock it with the steering stem nut (02273-02) provided. Make sure the coned side is against the bracket.

### NOTE!

Tighten the top nut of the steering stem to torque recommended in the motorcycle's workshop manual. If no recommended torque is available tighten to 100 Nm.

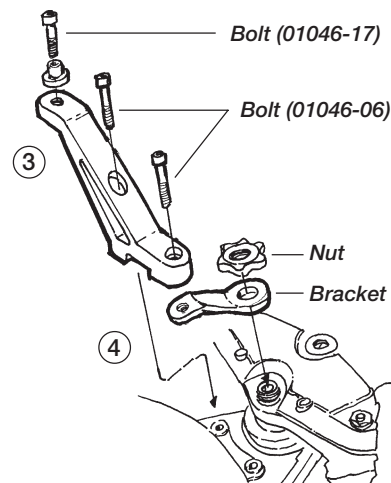

5

Attach the bracket assembly to the bracket arm. Use bolt (01046-17), sleeve (02239-01) and teflon spacer (02259-03).

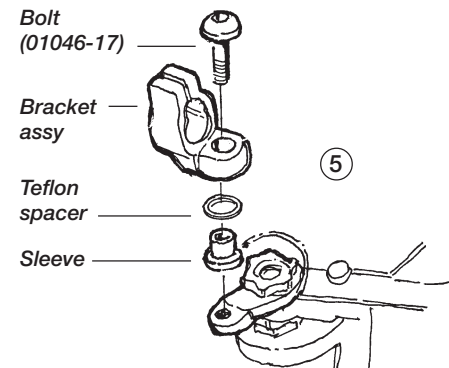

6

Fit the Öhlins steering damper to the two brackets. Use the bolt (01046-17) and sleeve (02239-01) on the the frame bracket.

