

Before installing this product, check the contents of the kit. If anything is missing, please contact an Öhlins dealer.

Kit Contents

	Part No	Pcs
SD 661	SD661	1
Steering stem screw	15872-01	1
Washer	15873-01	1
Handlebar clamp, upper	15810-28	2
Handlebar clamp, lower	15811-28	2
Screw (M6x14)	00431-10	2
Screw (M10x16)	00431-12	2
Screw (M6x12)	00432-11	1
Screw (M5x8)	01046-50	1
Screw (M5x35)	01046-56	1
Screw (M8x30)	15209-03	4
Frame bracket	15870-01	1
Sticker	00192-01	2

👁 Note!

Please note that this image is a general representation of the product and may differ slightly from your product.

👁 Note!

Please note that during storage and transportation, especially at high ambient temperature, some of the oil and grease used for assembling may leak and stain the packaging. This is in no way detrimental to the product, wipe off the excessive oil/grease with a cloth.

⚠ Warning!

Before installing this product, read the Öhlins Owner's Manual. The shock absorber/front fork/steering damper/stabilizer is an important part of your vehicle and will affect the stability.

Steering Stabilizer for KTM

SD 661

Mounting Instructions

MOUNTING INSTRUCTIONS

⚠ Warning!

It is advisable to have an Öhlins dealer install the shock absorber/front fork/steering damper/stabilizer.

⚠ Warning!

If working on a raised vehicle, ensure it is securely supported so that it will not tip.

👁 Note!

Before mounting this product clean the vehicle thoroughly.

👁 Note!

When working on this product, always see the Vehicle Service Manual for vehicle specific procedures and important data.

1

Remove the handle bar.

2

Remove the top nut.

3

Remove the triple clamp.

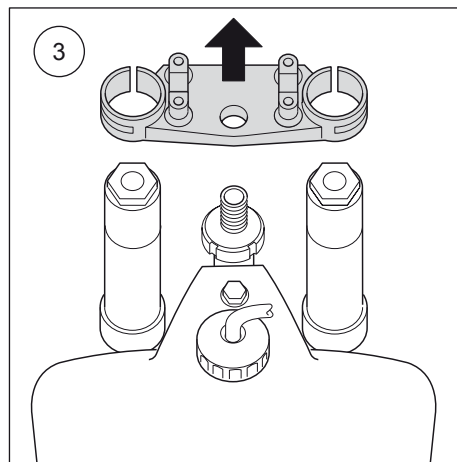
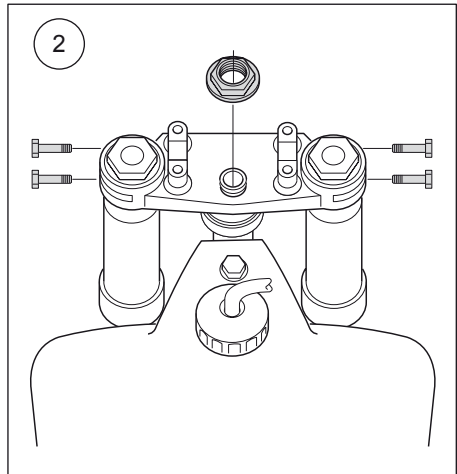
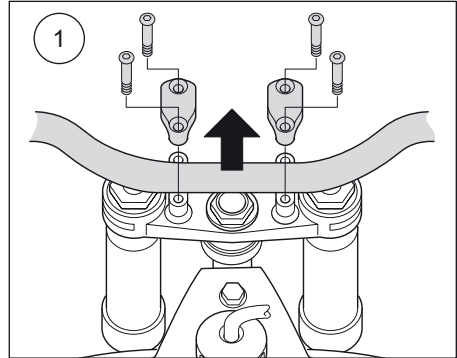

MOUNTING INSTRUCTIONS

4

Mount the Öhlins S3 triple clamp with the original o-ring, spacer (15873-01), and steering stem screw (15872-01). Tighten to 12 Nm and then further to the closest possible locking position with the screw (01046-56).

👁 Note!

The S3 triple clamp steering stem hole have a press fitting. It will be tough to press down to correct position.

5

Mont the frame link with screw (00432-11) in the frame mount (15879-01). Attach the frame bracket on the frame by tighten the screw (01046-56).

6

Mount the speedo-meter with screws (00431-10).

👁 Note!

Make sure that the screws do not block the damping unit.

7

Ensure that the bike steering stop works before the damper reaches its end position. Adjust the steering stop if necessary.

👉 Caution!

Ensure that all screws are tightened to the correct torque and that nothing fouls or restricts movement of the shock absorber/front fork/steering damper/stabilizer when the suspension is fully compressed or extended.

8

Mount the clamps for the handle bar.

There is a marking (C) in the upper clamps that should be directed in the driving direction. Ensure that there is a gap (D) between the upper and lower clamp. Tighten the forward screws (A) first, then tighten the remaining screws (B).

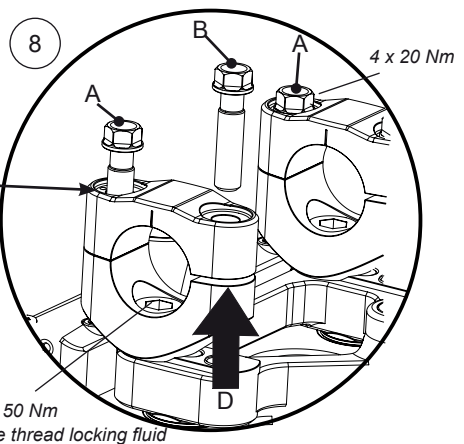
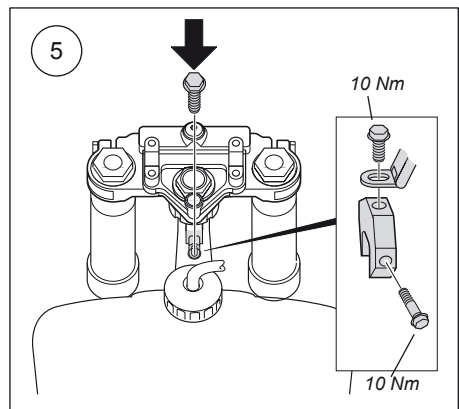
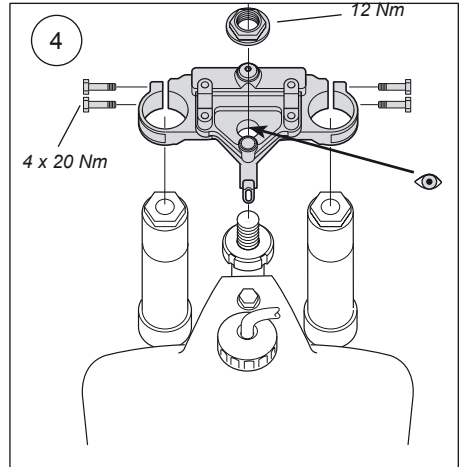
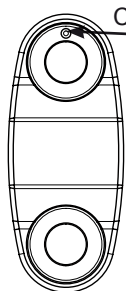

👁️ Öhlins products are subject to continuous improvement and development, therefore, although these instructions include the most up-to-date information available at the time of printing, minor updates may occur.

To find the latest information contact an Öhlins distributor. Please contact Öhlins if you have any questions regarding the contents in this document.

Part no. MI_SD661_3
Issued 2013-09-11

© Öhlins Racing AB. All rights reserved. Any reprinting or unauthorized use without the written permission of Öhlins Racing AB is prohibited.

Öhlins Racing AB
Box 722
S-194 27 Upplands Väsby, Sweden
Phone +46 8 590 025 00
fax +46 8 590 025 80



www.ohlins.com