

Kit Contents		
Description	Part No	Pcs
Tie-rod	00231-01	3
Screw M6x30	05404-07	2
Washer	00153-04	4
Nut	00430-02	2
Bracket	01165-30	1
Sticker set Öhlins	10207-01	1
Owners manual road & track	07241-02	1

**👁 Note!**

Please note that there can be small differences between your product and the images in these instructions.

**👁 Note!**

Please note that during storage and transport, especially at high ambient temperature, some of the oil and grease used for assembly may leak and stain the packaging. This will not cause damage to the product, wipe off the excessive oil or grease with a cloth.

**👁 Note!**

Before you install this product, check the kit contents. If anything is missing, please contact an Öhlins dealer.

**⚠ Warning!**

Before you install this product, read the Öhlins Owner's manual. This product is an important part of the vehicle and the vehicle stability.

## Shock absorber for BMW R18 and R18 Classic

# BM 180

## Mounting Instructions

# MOUNTING INSTRUCTIONS

## **⚠ Warning!**

*We strongly recommend to let an Öhlins dealer install this product.*

## **⚠ Warning!**

*If you work with a lifted vehicle, make sure that it is safely supported to prevent it from tipping over.*

## **👁 Note!**

*When you work with this product, see the vehicle service manual for vehicle specific procedures and important data.*

## **👁 Note!**

*Before you install this product clean the vehicle.*

**1**

Put the motorcycle on a work stand so that the rear wheel barely touches the ground.

**2**

Remove seat, right side cover and inner cover (tool kit).

**3**

Loosen upper shock absorber bolt.

**4**

Raise the rear of the motorcycle slightly, to clear lower bolt from carbon cannister. Loosen and remove rear bolt. Carefully let original shock absorber rest.

**5**

Loosen subframe bolts (4x) and carefully move subframe, just enough to be able to remove shock absorber. Remove original shock absorber.

**6**

Install shock absorber and route preload adjuster on the right hand side. Follow steps 4 and 3 backwards to fasten shock absorber.

**7**

Move subframe back into place and fasten it.

## **👁 Note!**

*Lower the vehicle so the suspension is slightly compressed before you tighten the screws.*

## **👋 Caution!**

*Make sure that you tighten all screws to the correct torque and that nothing fouls or restricts movement of the shock absorber/front fork/steering damper when the suspension is fully compressed or extended.*

**8**

Remove exhaust and the exhaust mount on right hand side.

**9**

Mount bracket (01165-30) between frame and exhaust mount and tighten bolts.

**10**

Route the preload adjuster hose as specified (see picture on next page) and mount adjuster on to bracket using screws (05404-07), washers (00153-04) and nuts (00430-02) Strap hose to frame using supplied tie-raps.

**11**

Remount side covers and seat.

# MOUNTING INSTRUCTIONS

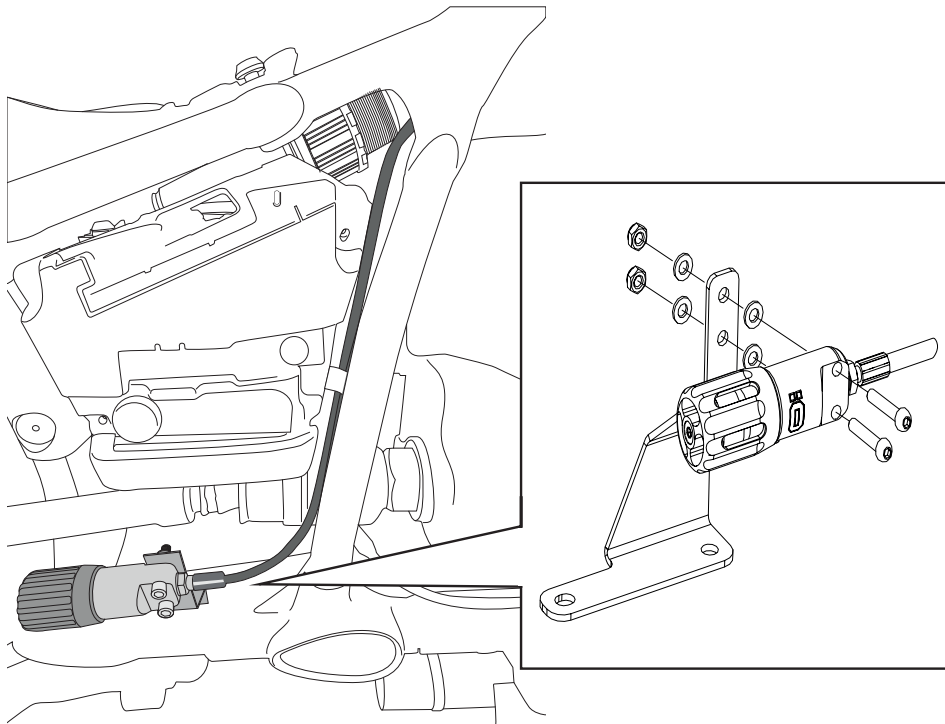

# ADJUSTMENTS

## ⚠ Warning!

Before you ride/drive, always make sure that the setup is according to the recommended setup data. Read about adjustments and setting up in the Öhlins Owner's Manual before you make any adjustments. Contact an Öhlins dealer if you have any questions about setting up.

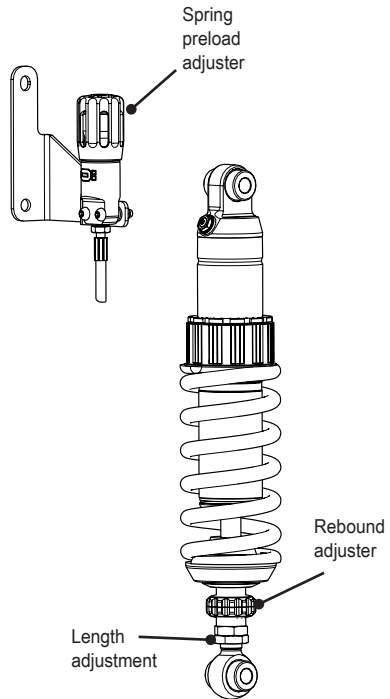

# SETUP DATA

Length	390.5 +9/-3	mm
Stroke	51.5	mm
Rebound	13	clicks
Spring preload	23	mm
Spring	21103-31	
Spring rate	95	N/mm
Spring free length	180	mm

Recommended free sag and ride height		
R1-R2	4	mm
R1-R3	25	mm
F1-F2 (std spring)	25	mm
F1-F3	35	mm

Öhlins products are subject to continuous improvement and development, therefore, although these instructions include the most up-to-date information available at the time of printing, minor updates may occur.

To find the latest information contact an Öhlins distributor. Please contact Öhlins if you have any questions regarding the contents in this document.

Part no. MI\_BM180\_0  
Issued 2022-12-01

© Öhlins Racing AB. All rights reserved. Any reprinting or unauthorized use without the written permission of Öhlins Racing AB is prohibited.

Öhlins Racing AB  
Box 722  
S-194 27 Upplands Väsby, Sweden  
Phone +46 8 590 025 00  
fax +46 8 590 025 80



[www.ohlins.com](http://www.ohlins.com)