



Kit Contents		
Description	Part No	Pcs
Cable ties 3,5x190		8
Cable ties 4,8x290		16
Adhesive pads		4
Holder		4
Cancellation k t		4

Note!

Please note that this image is a general representation of the product and may differ slightly from your product.

Cancellation kit, VAG PQ35 2003-2012

35020-14

Mounting Instructions

MOUNTING INSTRUCTIONS

⚠ Warning!

It is advisable to have an Öhlins dealer install the cancellation kit.

⚠ Warning!

If working on a raised vehicle, ensure it is securely supported.

Front axle, right vehicle side:

1

Fix the holder on the damper with cable ties 4,8 mm x 290 mm.

Mount the holder facing to the front of the vehicle as shown on the picture.

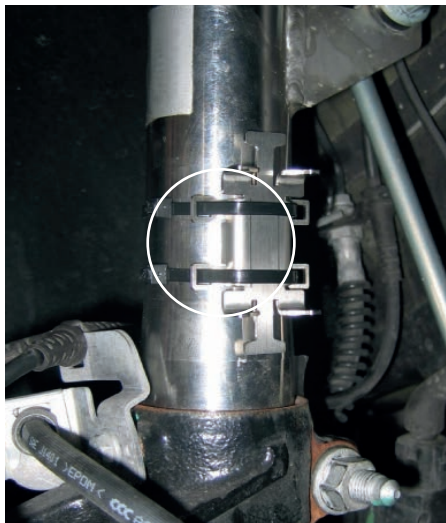

2

Fix the tape on the installed holder.

👁 Note!

Adherend must be cleaned and degreased.

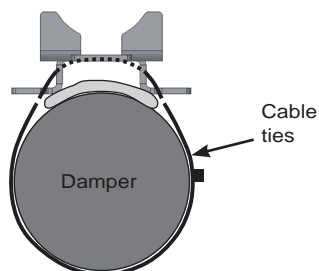

MOUNTING INSTRUCTIONS

⚠ Warning!

Make sure that the damper pipe has enough clearance on the complete spring travel.

3

Fix the supplied electronic component with cable ties 4,8 mm x 290 mm.
Run the standard damper control wire to the supplied electronic component connector.
Insert the standard connector into the electronic component connector until it locks.

4

Run the standard damper control wire around the coil over strut and fix it with the small cable ties.

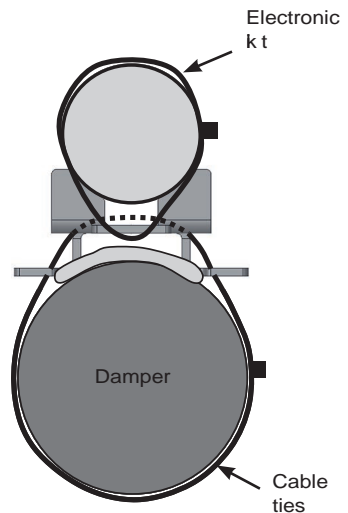

MOUNTING INSTRUCTIONS

Rear axle, left vehicle side:

5

Fix the holder on the damper with cable ties
4,8 mm x 290 mm.
Mount the holder slantwise facing outside to
the rear of the vehicle as shown on the picture.



6

Fix the tape on the installed holder.

Note!

Adherend must be cleaned and degreased.

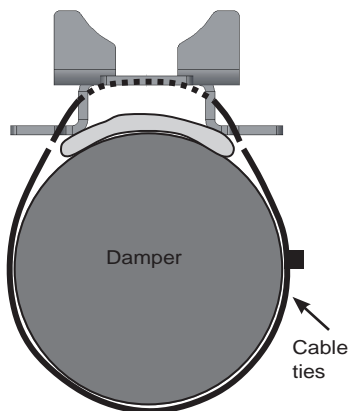

MOUNTING INSTRUCTIONS

⚠ Warning!

Make sure that the damper pipe has enough clearance on the complete spring travel.

7

Run the standard damper control and fix it with the small cable ties.

8

Fix the supplied electronic component with cable ties 4,8 mm x 290 mm.
Run the standard damper control wire to the supplied electronic component connector.
Insert the standard connector into the electronic component connector until it locks.

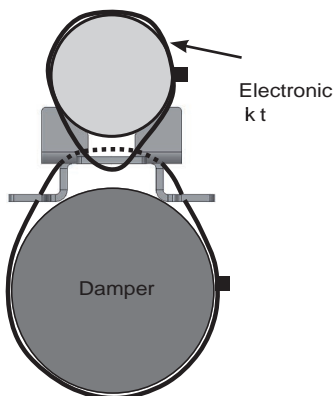

👁️ Öhlins products are subject to continuous improvement and development, therefore, although these instructions include the most up-to-date information available at the time of printing, minor updates may occur.

To find the latest information contact an Öhlins distributor. Please contact Öhlins if you have any questions regarding the contents in this document.

Part no. ML_35020-14_0
Issued 2016-05-17
Updated 2018-09-10

© Öhlins Racing AB. All rights reserved. Any reprinting or unauthorized use without the written permission of Öhlins Racing AB is prohibited.

Öhlins Racing AB
Box 722
S-194 27 Upplands Väsby, Sweden
Phone +46 8 590 025 00
fax +46 8 590 025 80



www.ohlins.com