



Kit Contents			
	Description	Part No	Pcs
1	Shock absorber	POS 5U00	2
2	Dust boot	10216-01	2
3	Plastic spacer	25602-01	2
4	Spring		
5	Rubber spring spacer	25601-01	2
6	Spacer	24629-34	2
7	Upper spring seat	25618-28	2
8	Lock nut M14	24627-04	2
9	C-spanner	24639-03	1
10	C-spanner	24639-01	1
11	Öhlins sticker kit	10207-01	1
12	Öhlins Owners Manual	07451-01	1

Additional parts to be purchased depending on model and equipment:			
13	Sleeve required for all 991 models	25649-02	2
14	PDCC bracket for 991 models, RHS	25616-13	1
15	PDCC bracket for 991 models, LHS	25616-14	1
16	Sleeve required for all 992 models	06245-04	2

**Note!**

Please note that there can be small differences between your product and the images in these instructions.

**Note!**

Please note that during storage and transport, especially at high ambient temperature, some of the oil and grease used for assembly may leak and stain the packaging. This will not cause damage to the product, wipe off the excessive oil or grease with a cloth.

**Note!**

Before you install this product, check the kit contents. If anything is missing, please contact an Öhlins dealer.

**Warning!**

Before you install this product, read the Öhlins Owner's manual. This product is an important part of the vehicle and the vehicle stability.

**Note!**

If the vehicle is equipped with OEM PASM shock absorbers, use Öhlins cancellation kit 35020-07

**Shock absorber Kit for Porsche:**

**991.1 & 991.2:** Turbo/S, Turbo/S cabriolet & Carrera 4/4S/4 GTS, Carrera 4/4S/GTS Cabriolet, Carrera Targa 4/4S/4 GTS

**992:** Carrera, S/4/4S, Targa 4/4S, Turbo/S

**POS MU00 front**

**Mounting Instructions**



# MOUNTING INSTRUCTIONS

## **⚠ Warning!**

We strongly recommend to let an Öhlns dealer install this product.

## **⚠ Warning!**

If you work with a lifted vehicle, make sure that it is safely supported to prevent it from tipping over.

## **👁 Note!**

When you work with this product, see the vehicle service manual for vehicle specific procedures and important data.

## **👁 Note!**

Before you install this product clean the vehicle.

**1**

Raise the vehicle and put it on jack stands and remove the front wheels.

**2**

Loosen the bolts for the lower strut attachments. Loosen the upper attachments and remove the original struts from the car

## **👋 Caution!**

Support the wheel hubs in an appropriate way on each side of the vehicle so that the brake hoses can not be damaged.

**3**

Cut the dust boot 62 mm from the lower end with a pair of scissors according to fig 2.

## **👁 Note!**

Remove the OE rubber spring isolator from the top mount according to fig 3 but keep the OE bearing.

**4**

### **For 991 models without PDCC:**

Thread on the height adjuster lock ring and fit the sleeve (13) according to Fig 4. Fit the dust boot (2), the plastic spring spacer (3), the spring (4), the rubber spring spacer (5), the spacer (6), the upper spring seat (7) the OE top mount, the OE washer and the M14 lock nut (8) to the strut according to Fig 1. Tighten the M14 lock nut to 35-40 Nm.

### **For 991 models with PDCC:**

Thread on the height adjuster lock ring, the PDCC bracket (14/15) and fit the sleeve (13) according to Fig 5. Fit the dust boot (2), the plastic spring spacer (3), the spring (4), the rubber spring spacer (5), the spacer (6), the upper spring seat (7) the OE top mount, the OE

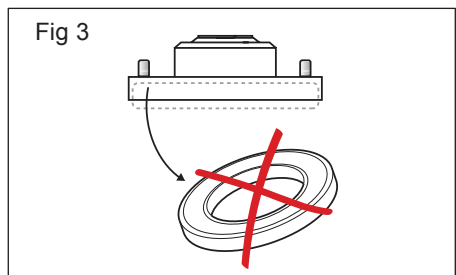
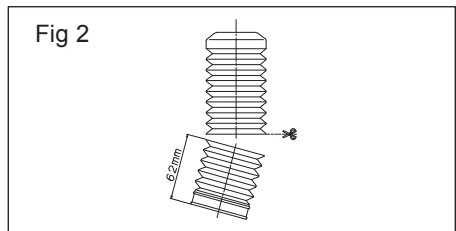
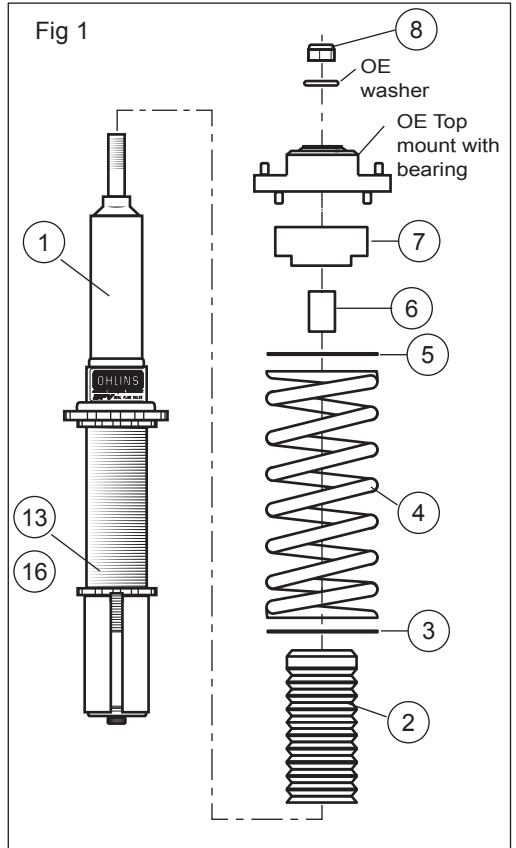

# MOUNTING INSTRUCTIONS

washer and the M14 lock nut (8) to the strut according to Fig 1. Tighten the M14 lock nut to 35-40 Nm.

## For 992 models:

Thread on the gold sleeve (16) according to Fig 6. Fit the dust boot (2), the plastic spring spacer (3), the spring (4), the rubber spring spacer (5), the spacer (6), the upper spring seat (7) the OE top mount, the OE washer and the M14 lock nut (8) to the strut according to figure 1. Tighten the M14 lock nut to 35-40 Nm.

## 👁 Note!

*When tightening the top mount nut, the shock absorber shaft must be held in position with an Allen key.*

## 5

### 991 without PDCC (Fig 7):

Set the spring preload and tighten the lock ring to 40-50 Nm. Adjust the height adjuster lock ring and tighten to 40-50 Nm.

### 991 with PDCC (Fig 8):

Set the spring preload and tighten the lock ring to 40-50 Nm. Position the PDCC bracket and align the guiding pin into the slit in the upright and tighten the PDCC bracket M6 screw to 12-15 Nm. Tighten the height adjuster lock ring to 40-50 Nm.

### 992 (Fig 9):

Set the spring preload and tighten the lock ring to 40-50 Nm. Adjust the height adjuster according to fig 9.

## 6

Fasten the upper attachments to the vehicle. Raise the wheel hub with a jack to remove the freplay of the lower strut attachment.

## 7

Tighten the OE upright bolts to the specified torque for the vehicle.

## 👁 Note!

*Make sure that all bolts are tightened to the correct torque and that nothing fouls or restricts movement of the strut when it is being fully compressed or extended. Test this over the whole steering range from lock to lock.*

Fig 4. 991 models without PDCC

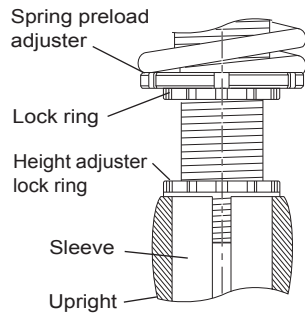

Fig 5. 991 models with PDCC

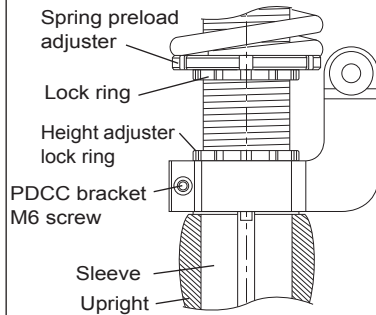
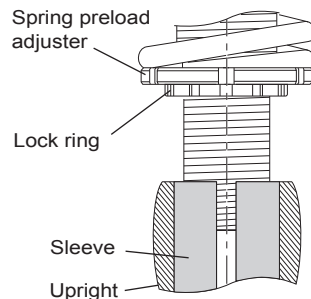

Fig 6. 992 models



## 8

Make sure that all removed parts are reinstalled in the same way as they were before the installation of the Öhlins shock absorber.

# ADJUSTMENTS

## **⚠ Warning!**

Before you ride/drive, always make sure that the setup is according to the recommended setup data. Read about adjustments and setting up in the Öhlins Owner's Manual before you make any adjustments. Contact an Öhlins dealer if you have any questions about setting up.

The recommended spring preload is 2 mm from a free length of 180 mm, giving 178 mm installed length, see Fig 7/8/9.

# SETUP DATA

## Recommended set-up

Setting		
Track	2-7	clicks
Winding road	5-10	clicks
Street	10-20	clicks
Spring preload	2	mm

## Recommended spring

48000-19 (70N/mm)

## Vehicle height adjustment range

With both the spring preload and height adjustments in their recommended positions, the vehicle is lowered approximately 10 mm when compared to the original suspension. Depending on car model and equipment, the spring preload may vary. Make sure that the spring is always preloaded.

Öhlins products are subject to continuous improvement and development, therefore, although these instructions include the most up-to-date information available at the time of printing, minor updates may occur.

© Öhlins Racing AB. All rights reserved. Any reprinting or unauthorized use without the written permission of Öhlins Racing AB is prohibited.

To find the latest information contact an Öhlins distributor. Please contact Öhlins if you have any questions regarding the contents in this document.

Öhlins Racing AB  
Box 722  
S-194 27 Upplands Väsby, Sweden  
Phone +46 8 590 025 00  
fax +46 8 590 025 80

Fig 7. 991  
without PDCC

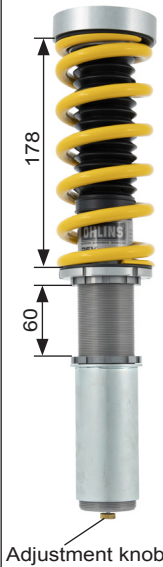

Fig 8. 991  
with PDCC

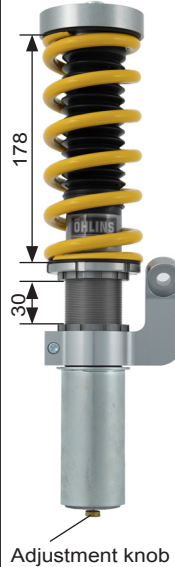
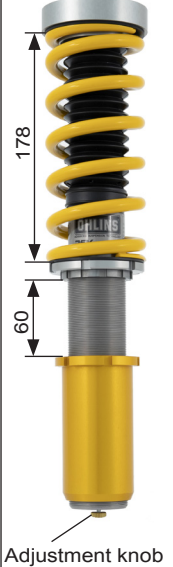

Fig 9. 992



## **⚠ Warning!**

The spring preload adjustment range is 2-10 mm, giving approximately 2-10 mm lower ride height. Moving the height adjuster outside the recommended position may cause the wheel to hit the fender liner.

Part no. MI\_POSMU00\_0  
Issued 2020-06-04



[www.ohlins.com](http://www.ohlins.com)



Kit Contents			
	Description	Part No	Pcs
1	Shock absorber	POS 6U00	2
2	Dust boot	10216-01	2
3	Plastic spring spacer	25602-01	2
4	Spring		2
5	Rubber spring spacer	25601-01	2
6	Upper spring seat	25618-16	2
7	Washer	24619-08	2
8	Lock nut M12	24618-04	2
9	Adjuster	24631-01	2
10	Control wire	24632-02	2
11	Adjustment wheel	24633-01	2
12	M4 Screw	24633-02	2

**Note!**

Please note that there can be small differences between your product and the images in these instructions.

**Note!**

Please note that during storage and transport, especially at high ambient temperature, some of the oil and grease used for assembly may leak and stain the packaging. This will not cause damage to the product, wipe off the excessive oil or grease with a cloth.

**Note!**

Before you install this product, check the kit contents. If anything is missing, please contact an Öhlins dealer.

**Warning!**

Before you install this product, read the Öhlins Owner's manual. This product is an important part of the vehicle and the vehicle stability.

**Note!**

If the vehicle is equipped with OEM PASM shock absorbers, use Öhlins cancellation kit 35020-07

**Shock absorber Kit for Porsche:**

**991.1 & 991.2:** Turbo/S, Turbo/S cabriolet, Carrera 4/4S/4 GTS, Carrera 4/4S/GTS Cabriolet, Carrera Targa 4/4S/4 GTS

**992:** Carrera, S/4/4S, Targa 4/4S, Turbo/S

**POS MU00 rear**

**Mounting Instructions**



# MOUNTING INSTRUCTIONS

## **⚠ Warning!**

*We strongly recommend to let an Öhlins dealer install this product.*

## **⚠ Warning!**

*If you work with a lifted vehicle, make sure that it is safely supported to prevent it from tipping over.*

## **👁 Note!**

*When you work with this product, see the vehicle service manual for vehicle specific procedures and important data.*

## **👁 Note!**

*Before you install this product clean the vehicle.*

**1**

Raise the vehicle and put it on jack stands.

## **⚠ Warning!**

*Ensure that it is securely supported.*

**2**

Remove the rear wheels.

**3**

Remove the lower and the upper attachments and remove the original shock absorbers.

**4**

Cut the dust boot 62 mm from the lower end with a pair of scissors according to fig 2.

**5**

Fit the dust boot (2), the plastic spring spacer (3), the spring (4), the rubber spring spacer (5), the upper spring seat (6), the OE top mount, the washer (7) and the M12 lock nut (8) to the strut according to fig 1.

Tighten the lock nut to 30 Nm. Install the adjuster (9) and tighten to 10 Nm.

## **👉 Caution!**

*When tightening the top mount nut, the shock absorber shaft must be held in position with an Allen key.*

**6**

Adjust the spring preload and then adjust the height adjuster according to fig 4 and tighten both lock rings to to 40-50 Nm with the c-spanners.

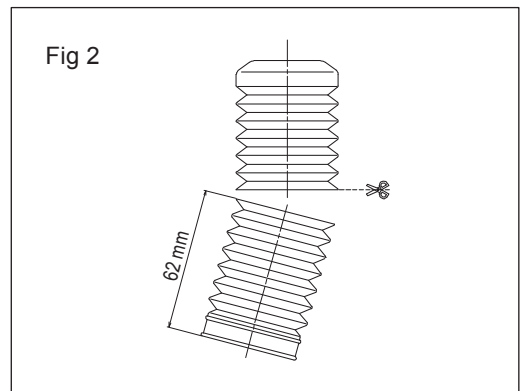
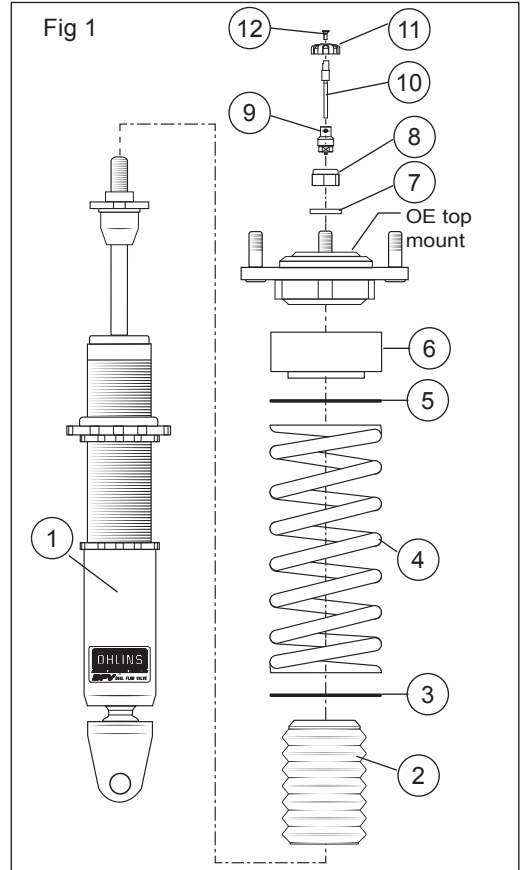

# MOUNTING INSTRUCTIONS

7

Install the Öhlins shock absorbers on the vehicle.

8

Make sure that all removed parts are reinstalled in the same way as they were before the installation of the Öhlins shock absorber.

**Note!**

*Make sure that all bolts are tightened to the correct torque and that nothing fouls or restricts movement of the shock absorber when it is being fully compressed or extended.*

9

Sub assemble the control wire (10) by fastening the adjustment wheel (11) to the wire with the M4 screw (12). Route the wire behind the interior panel according to Fig 3 and fasten the bottom end to the adjuster on the shock absorber with the supplied allen key.

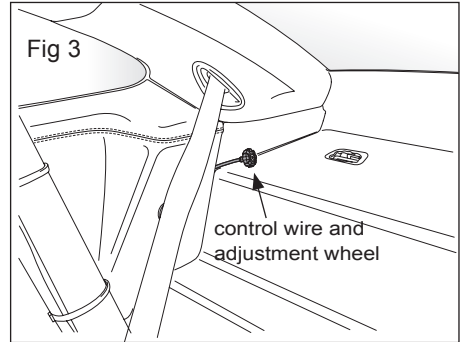

### **⚠ Warning!**

Before you ride/drive, always make sure that the setup is according to the recommended setup data. Read about adjustments and setting up in the Öhlins Owner's Manual before you make any adjustments. Contact an Öhlins dealer if you have any questions about setting up.

The preload is 2 mm from a free length of 200 mm, giving 198 mm installed length, see fig 4.

## SETUP DATA

### Recommended set-up

Rebound setting		
Track	2-7	clicks
Winding road	5-10	clicks
Street	10-20	clicks
Spring preload	5	mm

### Recommended spring

48010-47 (140N/mm)

### Vehicle height adjustment range

With both the spring preload and height adjustment in their recommended positions, the vehicle is lowered approximately 10 mm when compared to the original suspension. Depending on car model and equipment, the spring preload may vary. Make sure that the spring is always preloaded.

### **⚠ Warning!**

The spring preload adjustment range is 2-10 mm, giving approximately 2-10 mm lower ride height of the car. Moving the height adjuster outside the recommended position may cause the wheel to hit the fender liner.

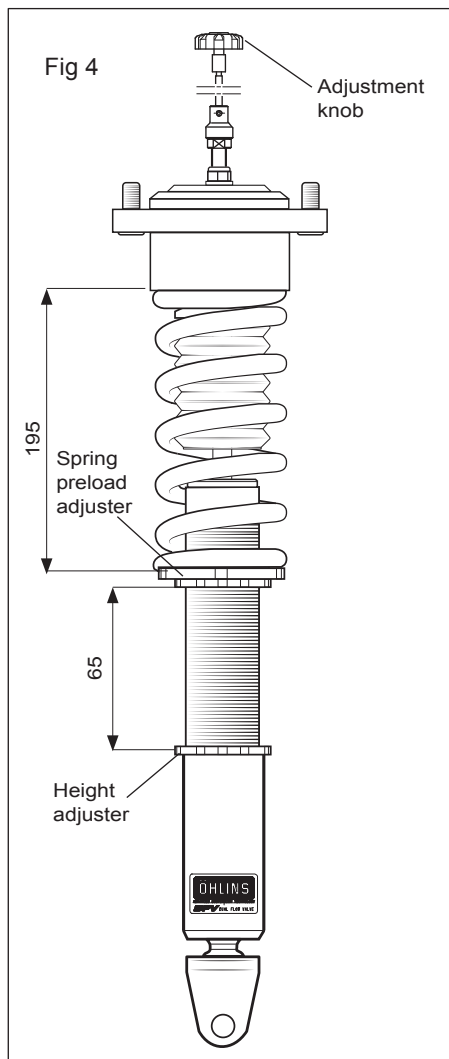

Öhlins products are subject to continuous improvement and development, therefore, although these instructions include the most up-to-date information available at the time of printing, minor updates may occur.

To find the latest information contact an Öhlins distributor. Please contact Öhlins if you have any questions regarding the contents in this document.

Part no. MI\_POSMU00\_0  
Issued 2020-09-08

© Öhlins Racing AB. All rights reserved. Any reprinting or unauthorized use without the written permission of Öhlins Racing AB is prohibited.

Öhlins Racing AB  
Box 722  
S-194 27 Upplands Väsby, Sweden  
Phone +46 8 590 025 00  
fax +46 8 590 025 80



[www.ohlins.com](http://www.ohlins.com)