

Kit Contents		
Description	Part No	Pcs
Shock absorber	HO 828	
Tie-rod	00231-01	3
Screw M6x14	00382-16	1
Screw M6x22	01046-05	2
Screw M6x12	01046-36	2
Bracket	01165-18	1
Sticker set Öhlins		1
Bracket reservoir	03102-20	1
Owners manual road & track	07241-02	1

👁 Note!

Please note that there can be small differences between your product and the images in these instructions.

👁 Note!

Please note that during storage and transport, especially at high ambient temperature, some of the oil and grease used for assembly may leak and stain the packaging. This will not cause damage to the product, wipe off the excessive oil or grease with a cloth.

👁 Note!

Before you install this product, check the kit contents. If anything is missing, please contact an Öhlins dealer.

⚠ Warning!

Before you install this product, read the Öhlins Owner's manual. This product is an important part of the vehicle and the vehicle stability.

Shock absorber for Honda CB 1000R

HO 828

Mounting Instructions

MOUNTING INSTRUCTIONS

⚠ Warning!

We strongly recommend to let an Öhlins dealer install this product.

⚠ Warning!

If you work with a lifted vehicle, make sure that it is safely supported to prevent it from tipping over.

👁 Note!

When you work with this product, see the vehicle service manual for vehicle specific procedures and important data.

👁 Note!

Before you install this product clean the vehicle.

1

Put the motorcycle on a work stand so that the rear wheel barely touches the ground.

2

Remove the mudguard, chain cover and left side foot peg. Remove lower shock absorber bolt, then upper bolt. Remove the shock absorber.

3

Lower the swing to gain more space. From the bikes left side, put the gas reservoir and hoses thru under brakelines.

4

Mount the shock absorber. The hose on the shock should point to the front of the bike.

👁 Note!

Lower the vehicle so that the suspension is slightly compressed before you tighten the screws.

5

Remove the right passenger foot peg. Mount the supplied bracket between the foot peg and the frame. Use the standard screws (see figure).

6

Install the gas reservoir and pre-load adjuster according to the figure. Use the supplied screws and use thread lock.

7

Tie up the hoses with the supplied ty-raps. Check that the hoses has no sharp bends or are squeezed somewhere when the rear suspension is compressed or extended.

👋 Caution!

Make sure that you tighten all screws to the correct torque and that nothing fouls or restricts movement of the shock absorber/front fork/steering damper when the suspension is fully compressed or extended.

MOUNTING INSTRUCTIONS

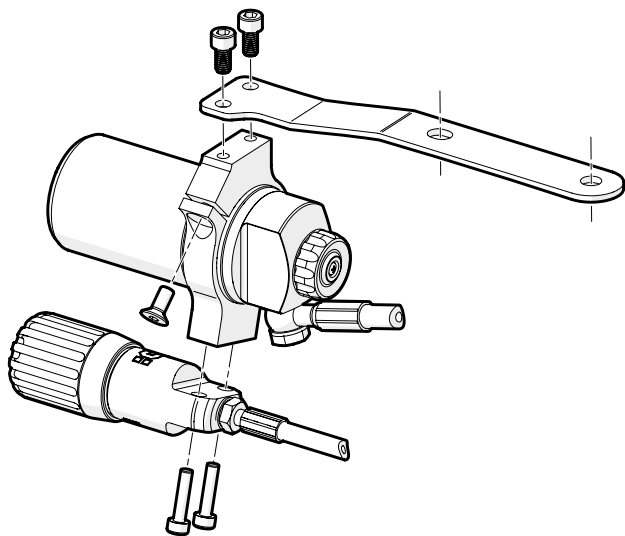
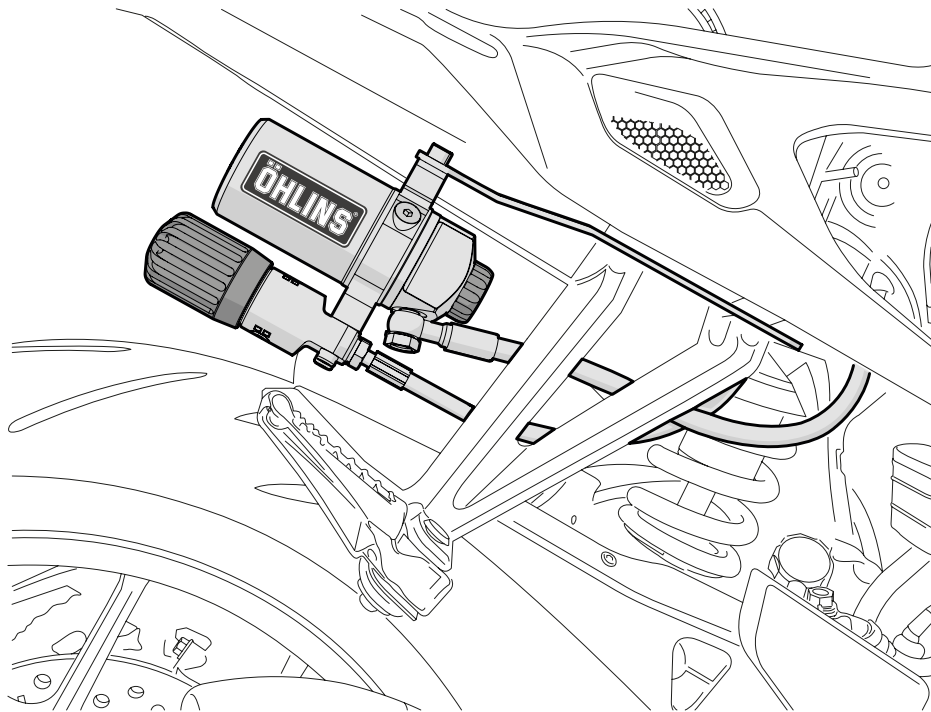

ADJUSTMENTS

⚠ Warning!

Before you ride/drive, always make sure that the setup is according to the recommended setup data. Read about adjustments and setting up in the Öhlins Owner's Manual before you make any adjustments. Contact an Öhlins dealer if you have any questions about setting up.

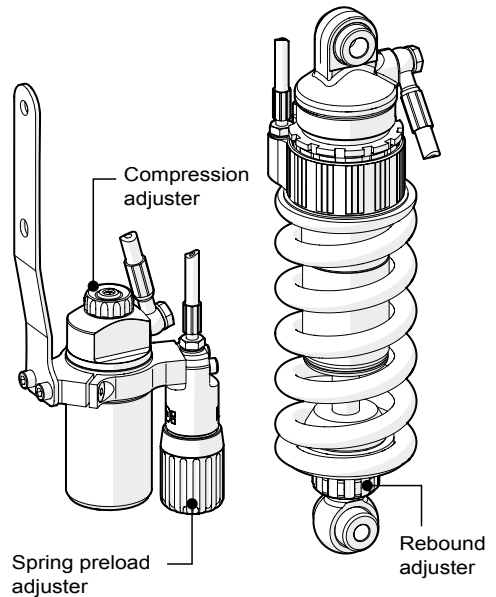

SETUP DATA

Length	309,5	mm
Stroke	49,5	mm
Compression	12	clicks
Rebound	17	clicks
Spring preload	7	mm
Spring	01092-64	
Spring rate	160	N/mm
Spring free length	170	mm

Recommended free sag and ride height		
R1-R2	18	mm
R1-R3	46	mm
F1-F2 (std spring)	29	mm
F1-F3	37	mm

Öhlins products are subject to continuous improvement and development, therefore, although these instructions include the most up-to-date information available at the time of printing, minor updates may occur.

To find the latest information contact an Öhlins distributor. Please contact Öhlins if you have any questions regarding the contents in this document.

Part no. MI_HO828_0
Issued 2019-07-16

© Öhlins Racing AB. All rights reserved. Any reprinting or unauthorized use without the written permission of Öhlins Racing AB is prohibited.

Öhlins Racing AB
Box 722
S-194 27 Upplands Väsby, Sweden
Phone +46 8 590 025 00
fax +46 8 590 025 80



www.ohlins.com