

Note!

Please note that this image is a general representation of the product and may differ slightly from your product.

Note!

Please note that during storage and transportation, especially at high ambient temperature, some of the oil and grease used for assembling may leak and stain the packaging. This is in no way detrimental to the product, wipe off the excessive oil/grease with a cloth.

Kit Contents

Description	Part No	Pcs
Shock absorber	HO1694	1
Spring clip	15629-02	1
Screw M6SF M10x50	00432-10	1
Lock nut M10	15010-01	1
Sticker Öhlins	10207-01	1
Owner's manual	07253-02	1
Cool Tool	24614-01	1

Note!

Before installing this product, check the contents of the kit. If anything is missing, please contact an Öhlins dealer.

Warning!

Before installing this product, read the Öhlins Owner's Manual. The shock absorber/front fork/steering damper is an important part of your vehicle and will affect the stability.

Shock absorber for Honda CRF 450R

HO 1694

Mounting Instructions



MOUNTING INSTRUCTIONS

Brand	Rider's weight * kg/pounds	Spring	Spring rate N/mm
HONDA CRF 450R	60/132	06310-09	50
	65/143	06310-09	50
	70/154	06310-10	52
	75/165	06310-10	52
	80/176	06310-11	54
	85/187	06310-11	54
	90/198	06310-12	56
	95/209	06310-12	56
	100/220	06310-13	58
	105/231	06310-14	60
	110/242	06310-15	62
	115/253	06310-16	64

* Rider's weight: Rider wearing all riding equipment

INSTALL THE SPRING

Note!

Install the spring on the shock absorber before installing the shock absorber on the vehicle.

- 1
Measure the free length of the spring (A).
- 2
Loosen the preload lock nut so that you can move the spring platform as far up as needed to install the spring.
- 3
Put the shock absorber up-side-down in a vice so that you can install the spring and the spring clip.

Note!

The spring platform and spring are press fitted. Push hard to install the spring.

- 4
Measure the spring length. Adjust the spring preload to the recommended setting, see section Adjustments and Setup data in this folder.

- 5
Install the shock absorber on the vehicle according to the procedure in this folder. Check sag and ride height (see the Owner's Manual) and adjust the spring preload again if necessary.

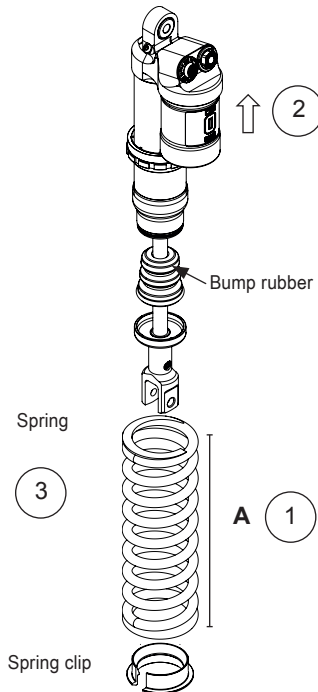

Note!

Tighten the preload lock nut before riding the motorcycle.

MOUNTING INSTRUCTIONS

⚠ Warning!

It is advisable to have an Öhlins dealer install the shock absorber/front fork/steering damper.

⚠ Warning!

If working on a raised vehicle, ensure it is securely supported so that it will not tip.

👁 Note!

Before mounting this product clean the vehicle thoroughly.

👁 Note!

When working on this product, always see the Vehicle Service Manual for vehicle specific procedures and important data.

👁 Note!

Lower the vehicle so that the suspension is slightly compressed before tightening the screws.

👋 Caution!

Ensure that all screws are tightened to the correct torque and that nothing fouls or restricts movement of the shock absorber/front fork/steering damper when the suspension is fully compressed or extended.

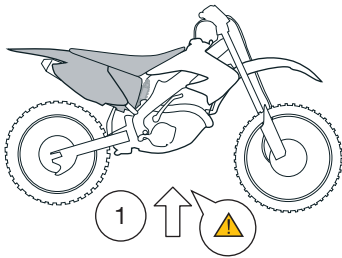

1

Put the motorcycle on a workstand so that the rear wheel barely touches the ground.

2

Install the Öhlins shock absorber according to the vehicle service manual. Replace the original top mounting screw with screw (00432-10) and lock nut (15010-01) provided in this kit. Insert the screw in the opposite direction compared to the original screw.

3

Reinstall all removed parts as they were before the installation of the Öhlins shock absorber.

ADJUSTMENTS

⚠ Warning!

Before riding, always make sure that the basic settings made by Öhlins are according to recommended Set-up Data. Read about adjustments and setting up in the Öhlins Owner's Manual before you make any adjustments. Contact an Öhlins dealer if you have any questions about setting up.

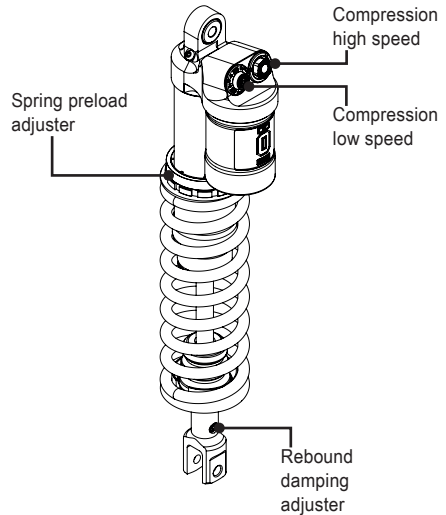

SETUP DATA

Length	479	mm	R1-R2 (free sag)	38±3	mm
Stroke	151	mm	R1-R3 (ride height)	103±3	mm
Rebound	25	clicks			
Compression high speed	Set to II	clicks			
Compression low speed	12	clicks			
Spring preload	10	mm			

(approx 5 turns)

Free Sag and Ride Height

👁 Öhlins products are subject to continuous improvement and development, therefore, although these instructions include the most up-to-date information available at the time of printing, minor updates may occur.

To find the latest information contact an Öhlins distributor. Please contact Öhlins if you have any questions regarding the contents in this document.

Part no. MI_HO1694_0
Issued 2015-09-10



© Öhlins Racing AB. All rights reserved. Any reprinting or unauthorized use without the written permission of Öhlins Racing AB is prohibited.

Öhlins Racing AB
Box 722
S-194 27 Upplands Väsby, Sweden
Phone +46 8 590 025 00
fax +46 8 590 025 80



www.ohlins.com