

Kit Contents		
Description	Part No	Pcs
STX Cartridge Kit	FGKT1990	1
Cartridge sticker	00191-34	2
Sticker set Öhlins		1
Owner's manual	07298-05	1
Base plug (with o-rings)	15430-04	1
Safety clip	15440-01	1
Spacer	15494-02	14
Hydraulic stop cup	15456-21	1
Sticker service schedule MX fork & shock	15211-01	1

👁 Note!

No springs included in this kit. Use Öhlins Front Fork springs, part no 08789-xx. See the spring guide in this folder or contact Öhlins for advice.

👁 Note!

Please note that there can be small differences between your product and the images in these instructions.

👁 Note!

Please note that during storage and transport, especially at high ambient temperature, some of the oil and grease used for assembly may leak and stain the packaging. This will not cause damage to the product, wipe off the excessive oil or grease with a cloth.

👁 Note!

Before you install this product, check the kit contents. If anything is missing, please contact an Öhlins dealer.

⚠ Warning!

Before you install this product, read the Öhlins Owner's manual. This product is an important part of the vehicle and the vehicle stability.

STX Cartridge Kit for KTM 85 SX and Husqvarna TC85

FGKT 1990

Mounting Instructions



MOUNTING INSTRUCTIONS

Remove the original fork legs

⚠ Warning!

We strongly recommend to let an Öhlins dealer install this product.

⚠ Warning!

If you work with a lifted vehicle, make sure that it is safely supported to prevent it from tipping over.

👁 Note!

When you work with this product, see the vehicle service manual for vehicle specific procedures and important data.

👁 Note!

Before you install this product clean the vehicle.

1
Place the motorcycle on a work stand so that the front wheel barely touches the ground.

2
Remove the front wheel, plastic fork leg protectors and the brake caliper.

3
Measure the distance from the top of the fork leg to the top of the upper triple clamp, see figure.

Note measure

Fork height position	
----------------------	--

4
Loosen the upper triple clamp screws.

5
Loosen the top cap ½ turn. Use a 45 mm hexagonal fork cap tool.

6
Loosen the lower triple clamp screws.

7
Remove the fork legs from the vehicle.

8
Clean the fork legs, make sure to clean underneath the fork bottom.

9
Refer to the vehicle service manual to remove the original front fork and spring from the fork leg. Turn the fork legs upside down and pour out all oil.

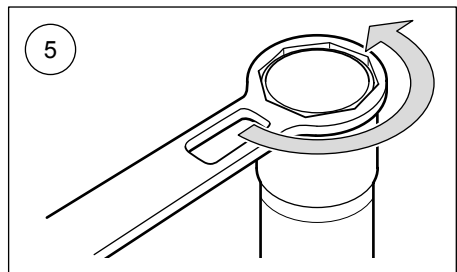
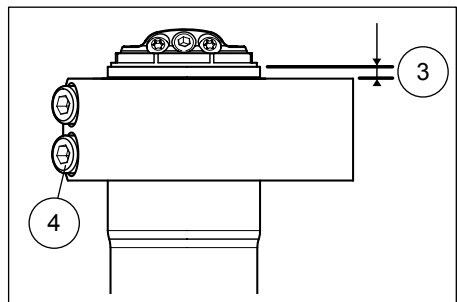
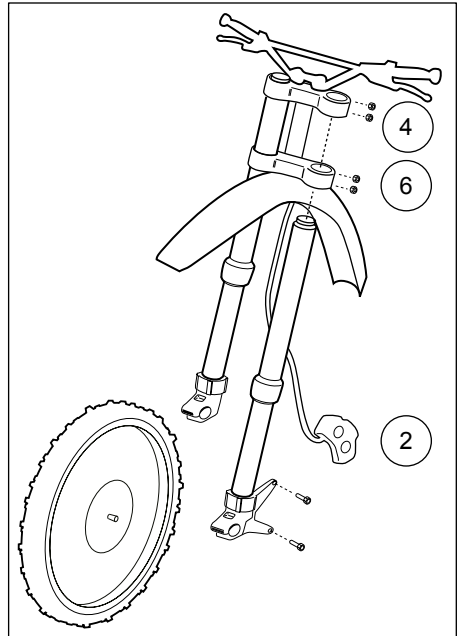

MOUNTING INSTRUCTIONS

Install the longer Öhlins cartridge with black plastic tube in right fork leg

10

Use contact cleaner to clean the contact surfaces between the hydraulic stop cup and the fork bottom.

Insert the hydraulic stop cup in the original fork leg, insert from the upper end of the fork tube.

⚠ Caution!

Make sure that the hydraulic stop cup is in correct position before you tighten.

11

Install and tighten the base plug into the fork bottom, tighten to 45 Nm.

⚠ Caution!

If the hydraulic stop cup rotates when you install and tighten, carefully use an impact machine.

12

Apply grease on the thread of the piston rod end.

13

Insert, if any, the preload washer/s, recommended spring and the cartridge kit into the original fork leg.

👁 Note!

Place the preload washer/s below the spring, at the bottom end of the fork leg.

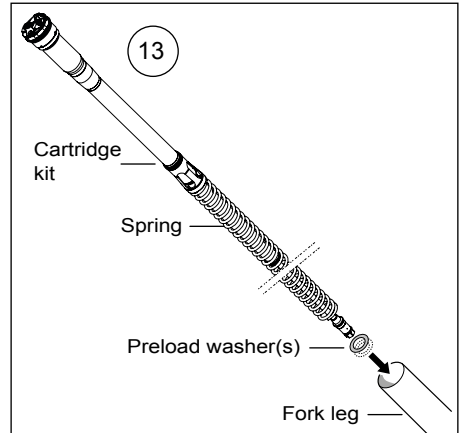
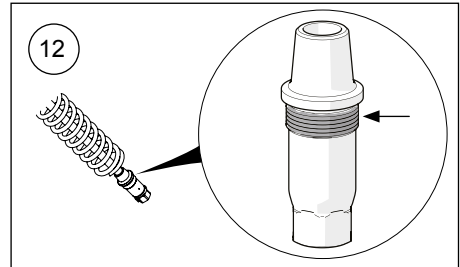
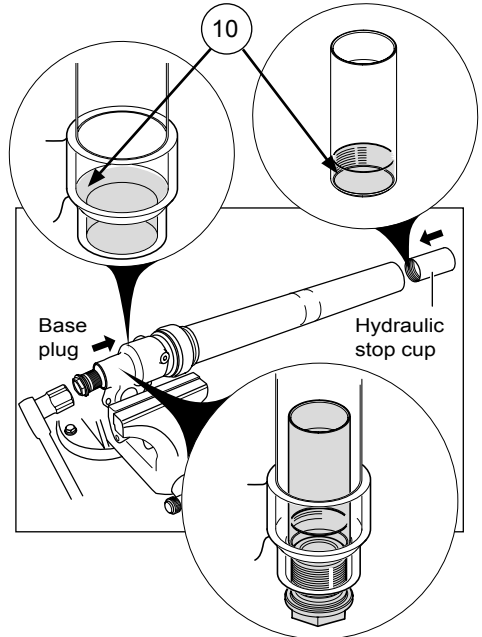

MOUNTING INSTRUCTIONS

14

Use a 12 mm socket to tighten the cartridge shaft end into the base plug, turn counter clockwise and tighten to maximum 18 Nm. Do not over tighten.

15

Install the security snap-ring at the shaft end groove.

16

Pour Öhlins Front fork fluid in the fork leg, refer to the recommended setup in Setup data.

17

Make sure that the front fork is fully extended. Use a 44 mm octagon fork cap tool to tighten the Öhlins fork top cap to maximum 10 Nm.

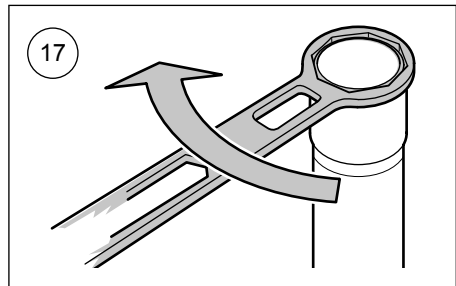
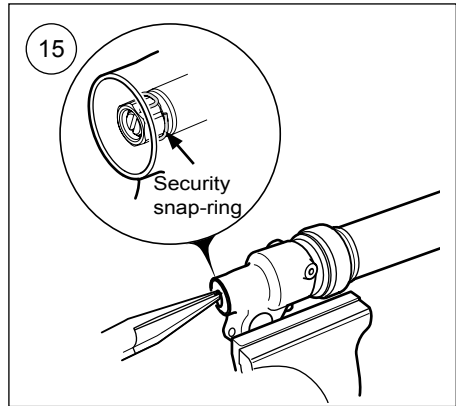
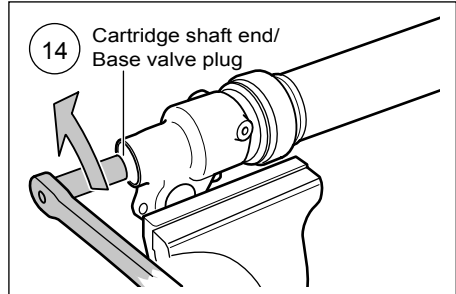

Install the shorter Öhlins cartridge with blue plastic tube in left fork leg (brake side)

18

Insert, if any, the preload washer/s, recommended spring and the cartridge kit into the original fork leg.

19

Reuse the OEM M10 bottom screw and seal washer and apply grease on the thread.

20

Make sure that the cartridge is in the lowest position. Refer to vehicle service manual for threadlocker and tightening torque. Install bottom screw and seal washer. Use tool 7 mm allen key to tighten bottom bolt.

21

Pour Öhlins Front fork fluid in the fork leg, refer to the recommended setup in Setup data.

22

Make sure that the front fork is fully extended. Use a 44 mm octagon fork cap tool to tighten the Öhlins fork top cap to maximum 10 Nm.

23

Check and set the rebound and compression valves click positions, refer to the recommended setup in Setup data.

24

Install the front fork legs into the triple clamps. Set the fork legs at the same height position as before. Refer to the vehicle service manual for correct tightening torque.

25

Install the brake caliper and the front wheel. Make sure that all removed parts are installed in the same positions that they were before.

👁 **Note!**

It is very important to tighten the triple clamps to the correct torque, refer to the vehicle service manual.

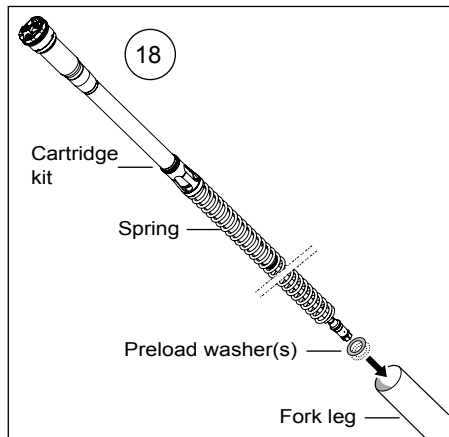

MOUNTING INSTRUCTIONS

ADJUSTMENTS

⚠ Warning!

Before you ride/drive, always make sure that the setup is according to the recommended setup data. Read about adjustments and setting up in the Öhlins Owner's Manual before you make any adjustments. Contact an Öhlins dealer if you have any questions about setting up.

SETUP DATA

Rebound adjustment (right fork leg only)	15	clicks
Compression adjustment	15	clicks
Spring preload**	0	mm
Total spring installation length (left side)	429	mm
Total spring installation length (right side)	425	mm
Fluid volume (each leg)	0,280	litre
Fluid volume range	0,250-0,350	litre
Öhlins Front Fork fluid	01330-XX	
Spring preload range*	0-6	mm

*Can be adjusted by adding/removing washer 15494-XX.

**To achieve specified spring preload the total spring installation length can be controlled prior installation into fork leg. See model specific length in setup data.

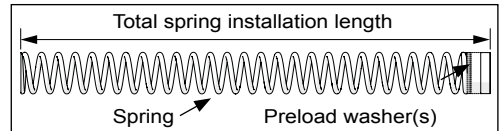

SPRING GUIDE

KTM 85 SX and Husqvarna TC85		
Rider's weight kg/lbs*	Part No	Spring rate N/mm
<35/77	08789-30	30
40/88	08789-32	32
45/99	08789-34	34
50/110	08789-34	34
55/121	08789-36	36
60/132	08789-38	38
> 70/154	08789-40	40

** Rider's weight: Rider wearing proper riding gear. Make sure you know your total weight with riding gear.*

Riding gear weighs between 5 and 15 kg.

Öhlins products are subject to continuous improvement and development, therefore, although these instructions include the most up-to-date information available at the time of printing, minor updates may occur.

To find the latest information contact an Öhlins distributor. Please contact Öhlins if you have any questions regarding the contents in this document.

Part no. MI_FGKT1990_1
Issued 2018-08-30

© Öhlins Racing AB. All rights reserved. Any reprinting or unauthorized use without the written permission of Öhlins Racing AB is prohibited.

Öhlins Racing AB
Box 722
S-194 27 Upplands Väsby, Sweden
Phone +46 8 590 025 00
fax +46 8 590 025 80



www.ohlins.com