

Kit Contents		
Description	Part No	Pcs
Shock absorber	POF5Q00	1
Sticker Öhlins	00192-01	1
Washer 6.4/12.3/3	00426-01	1
Helper spring	05173-15	1
Spring support 60/80/15	05193-07	1
Lock nut M14X1.5/9.5	05359-01	1
Spacer	05688-02	2
Spring seat 14/78.5/14.8	06211-01	1
Owner's manual	07446-01	1
Spring 61/150/120	25039-12	1
Heat shrinkable end cap	25042-01	1
Elastic spacer 60/78/2	25601-02	1

**Note!**

Please note that there can be small differences between your product and the images in these instructions.

**Note!**

Please note that during storage and transport, especially at high ambient temperature, some of the oil and grease used for assembly may leak and stain the packaging. This will not cause damage to the product, wipe off the excessive oil or grease with a cloth.

**Note!**

Before you install this product, check the kit contents. If anything is missing, please contact an Öhlins dealer.

**Warning!**

Before you install this product, read the Öhlins Owner's manual. This product is an important part of the vehicle and the vehicle stability.

## Shock absorber for Porsche 997 GT3 RS - front

# POF 5Q00

## Mounting Instructions

# MOUNTING INSTRUCTIONS

## **⚠ Warning!**

*We strongly recommend to let an Öhlins dealer install this product.*

## **⚠ Warning!**

*If you work with a lifted vehicle, make sure that it is safely supported to prevent it from tipping over.*

## **👁 Note!**

*When you work with this product, see the vehicle service manual for vehicle specific procedures and important data.*

## **👁 Note!**

*Before you install this product clean the vehicle.*

**1**

Remove the wheel.

**2**

Remove the anti-roll bar link at the lower joint.

**3**

Remove the brake hose attachment.

**4**

Disconnect the PASM wire to the shock absorber. The wire is located at the lower end of the original shock absorber.

**5**

Remove the brake caliper and support it so that the brake hose can not be damaged.

**6**

Loosen the upper attachment nut. Loosen the upper mount, 3 nuts. Remove the upper mount from the strut.

**7**

Loosen the lower attachment of the original shock absorber.

**8**

Push the shock absorber and A-arm down so that you can remove the shock absorber without touching the fender.

**9**

Pull out the shock absorber from the upright bracket to remove it.

**10**

Install the springs and provided parts on the shock absorber according to figure 10.

**11**

Install the Öhlins shock absorber in the upright bracket with the reservoir bracket pointing towards the rear.

**12**

Tighten the upper attachment nut.

**13**

Install the anti-roll bar link.

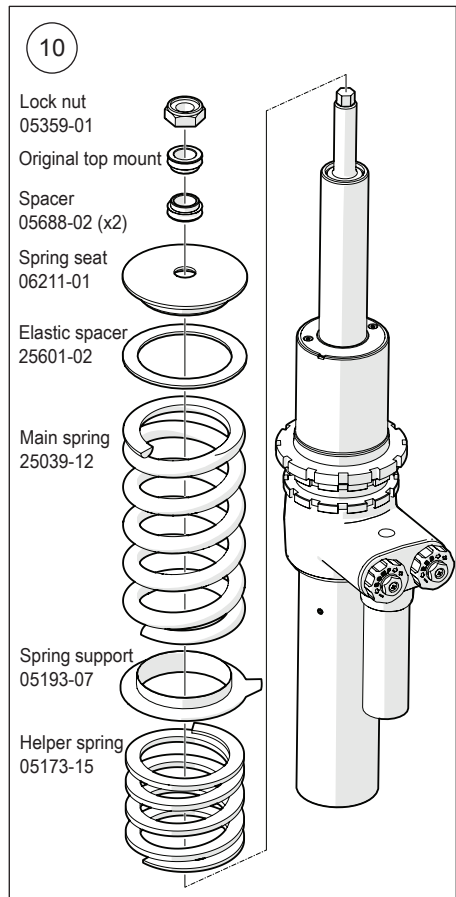

# MOUNTING INSTRUCTIONS

## 14

Install the (spacer 00426-01), provided in this kit, to achieve more space against the reservoir tube. See figure. Attach the brake hose.

## 15

Attach the wheel speed sensor harness.

## 16

Attach the brake caliper.

## 17

Install the wheel.

## 18

Carefully apply heat to shrink the heat shrinkable end cap over the PASM connector to protect it.

## 👁 **Note!**

*Since the original shock absorber and the electric wire are disconnected there will be an error indication on the dashboard "PASM failure". Contact a Porsche dealer to have the message turned off.*

## 19

After you have installed all shock absorbers, front and rear, check the vehicle ride height and adjust if necessary, see the Owner's manual. See the vehicle service manual for recommended ride height.

## 👋 **Caution!**

*Make sure that you tighten all screws to the correct torque and that nothing fouls or restricts movement of the shock absorber/front fork/steering damper when the suspension is fully compressed or extended.*

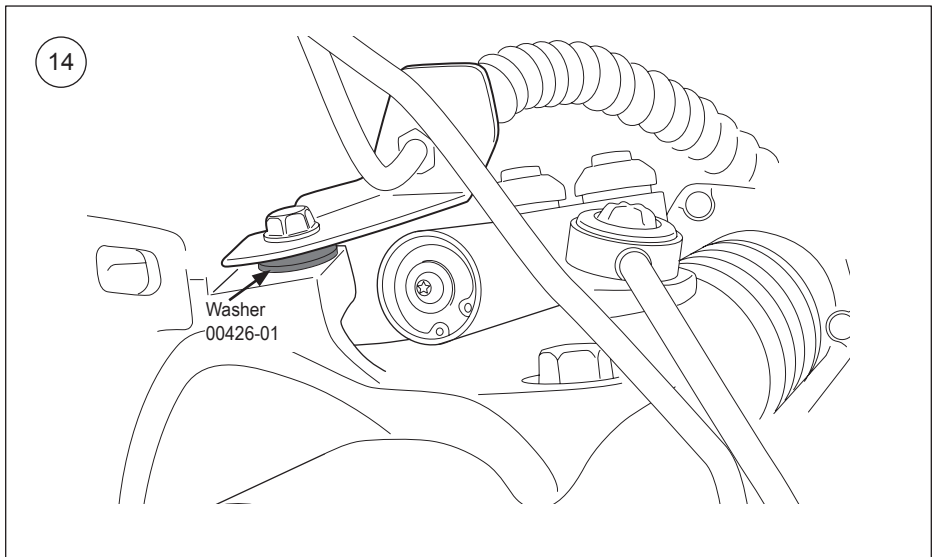

# ADJUSTMENTS

## ⚠ Warning!

Before you ride/drive, always make sure that the setup is according to the recommended setup data. Read about adjustments and setting up in the Öhlins Owner's Manual before you make any adjustments. Contact an Öhlins dealer if you have any questions about setting up.

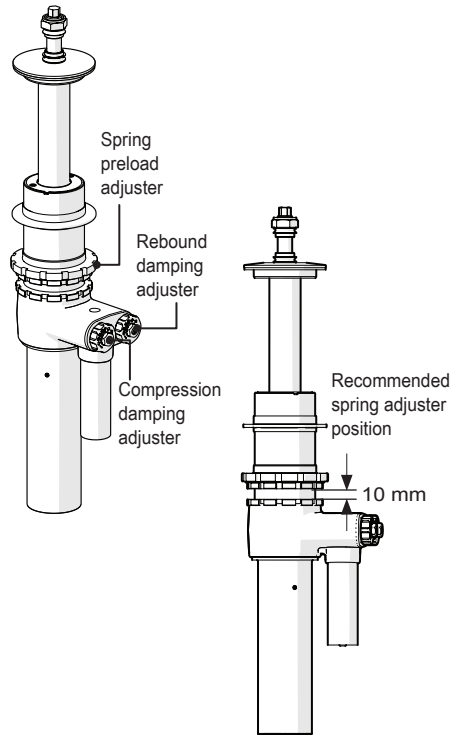

# SETUP DATA

	Street	Track
Compression damping	14 clicks	10 clicks
Rebound damping	12 clicks	14 clicks
<b>Provided springs</b>		
<b>Main spring</b>		
Spring rate	120	N/mm
Spring free length	150	mm
ID Ø	61	mm
<b>Helper spring</b>		
ID Ø	61	mm

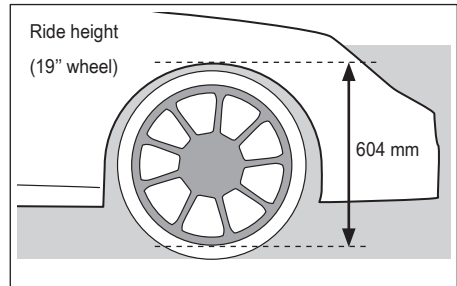

Öhlins products are subject to continuous improvement and development, therefore, although these instructions include the most up-to-date information available at the time of printing, minor updates may occur.

To find the latest information contact an Öhlins distributor. Please contact Öhlins if you have any questions regarding the contents in this document.

Part no. MI\_POF5Q00\_0  
Issued 2016-03-16

© Öhlins Racing AB. All rights reserved. Any reprinting or unauthorized use without the written permission of Öhlins Racing AB is prohibited.

Öhlins Racing AB  
Box 722  
S-194 27 Upplands Väsby, Sweden  
Phone +46 8 590 025 00  
fax +46 8 590 025 80



[www.ohlins.com](http://www.ohlins.com)