

## Check sag and ride height

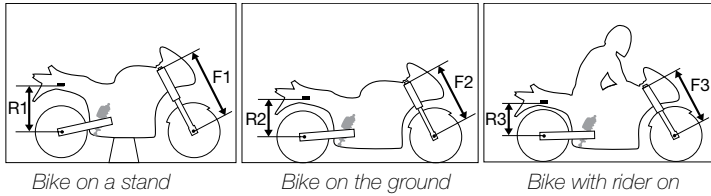

### Front suspension

F1. Bike on a stand with the suspension fully extended = .....

F2. Bike on the ground without rider = .....

F3. Bike on the ground with rider = .....

Free sag F1 - F2 = .....

Ride height F1 - F3 = .....

### Rear suspension

R1. Bike on a stand with the suspension fully extended = .....

R2. Bike on the ground without rider = .....

R3. Bike on the ground with rider = .....

Free sag R1 - R2 = .....

Ride height R1 - R3 = .....

### Set-up data

Shock absorber length	296 mm
Shock absorber stroke	71 mm
Spring pre-load	21 mm

### NOTE!

Read more about sag and ride height and different settings in your Öhlins Owner's manual.

## Adjustments

### Spring pre-load adjuster

Adjust by changing the position of the upper spring seat.

### NOTE!

When delivered the Öhlins shock absorber is dialed to recommended settings for the specific brand and make of the vehicle.

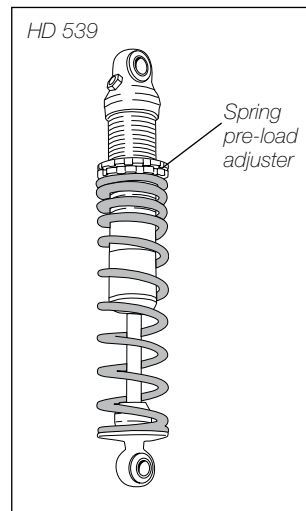

HD 539, issued 2005 12 19

# Mounting Instructions

Öhlins shock absorber kit HD 539  
for Harley-Davidson FLHRS Road King

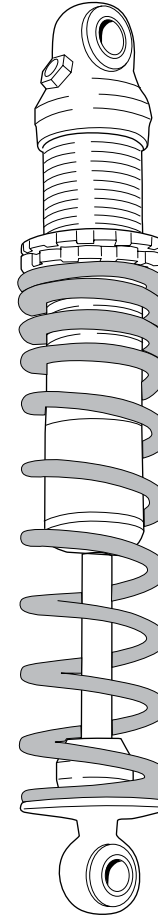

### Kit Contents

Before installing the shock absorber, please check the contents of the kit. If anything is missing, please contact your Öhlins dealer.

Description	Article no.
Shock absorber DRS	HD 539 (1)
C-spanner	00710-01 (2)
Sleeve	00123-13 (4)
Washer	03118-08 (8)
Sticker Öhlins	00192-01 (2)
Öhlins Owner's manual	(1)

### Before Installing

Öhlins Racing AB cannot be held responsible for any damage to shock absorber or vehicle, or injury to persons, if the instructions for fitting and maintenance are not followed exactly.

Similarly, the warranty will become null and void if the instructions are not adhered to.

Öhlins products are subject to continuous improvement and development. Consequently, although these instructions include the most up-to-date information available at the time of printing, there may be minor differences between your shock absorber and this manual. Please consult your Öhlins dealer if you have any questions regarding the contents of this manual.



Öhlins Racing AB, Box 722, S-194 27 Upplands Väsby, Sweden.  
Phone +46 8 590 025 00. Fax +46 8 590 025 80.

[www.ohlins.com](http://www.ohlins.com)

© Öhlins Racing AB. All rights reserved. Any reprinting or unauthorized use without the written permission of Öhlins Racing AB is prohibited. Printed in Sweden.



## Safety Signals

Important information concerning safety is distinguished in this manual by the following notations:



The Safety alert symbol means:  
Attention! Your safety is involved.



### WARNING!

Failure to follow these warning instructions could result in **severe or fatal injury** to anyone working with, inspecting or using the shock absorber, or to bystanders.

### CAUTION!

Caution indicates that special precautions must be taken to avoid damage to the shock absorber.

### NOTE!

Indicates information that is of importance regarding mounting procedures.

### WARNING!

1. Installing a shock absorber, that is not approved by the vehicle manufacturer, may affect the stability of your vehicle. Öhlins Racing AB cannot be held responsible for any personal injury or damage that may occur after fitting the shock absorber. Contact an Öhlins dealer or other qualified person for advice.

2. Please study and make certain that you fully understand all the mounting instructions and the owner's manual before handling this shock absorber kit. If you have any questions regarding proper installation procedures, contact an Öhlins dealer or other qualified person.

3. The vehicle service manual must be referred to when installing the Öhlins shock absorber

### NOTE!

During storage and transportation, especially at high ambient temperature, the oil and grease used for assembling may run out inside the packing and damage the expanded polystyrene packing material. This is not unusual and is in no way detrimental to the shock absorber.

## Mounting Instructions

### WARNING!

1. It is advisable to have an Öhlins dealer or other qualified person install the shock absorber.
2. Follow the instructions in the vehicle service manual when changing the shock absorber.
3. When working on a raised vehicle, make sure that it is securely supported to prevent it from falling.

### 1

Put the motorcycle on a workstand so that the rear wheel is off the ground. **Make sure the vehicle is securely supported so that it will not fall over.**

### 2

Loosen the upper and the lower attachments of the original shock absorber.

### 3

Install the Öhlins shock absorber in the same way as the original unit.

### NOTE!

Normally the shock absorber is mounted with the cylinder head upwards. Check that there is enough clearance to other details both in loaded and unloaded position.

### 4

Read more about your shock absorber in the Öhlins owner's manual.

### NOTE!

Make sure that all bolts are tightened to the correct torque and that nothing fouls or restricts movement of the shock absorber when the suspension is being fully compressed or extended.

3

