



# RECOMMENDATION LIST

## MOTORCYCLE 2015





## CHOOSING AN ÖHLINS SHOCK IS SIMPLE... SINCE WE HAVE MADE THE CHOICE FOR YOU!

Based on your bike's performance, its price and available mounting space we have designed a shock that we think suits it, both when it comes to price and performance.

We start by choosing a type which we tailor make for your specific bike. The basic setup, the design of the shim stacks and the calibration of the adjusters, is tested both on road

and track. They are the results of true tests with your bike and no guesswork!







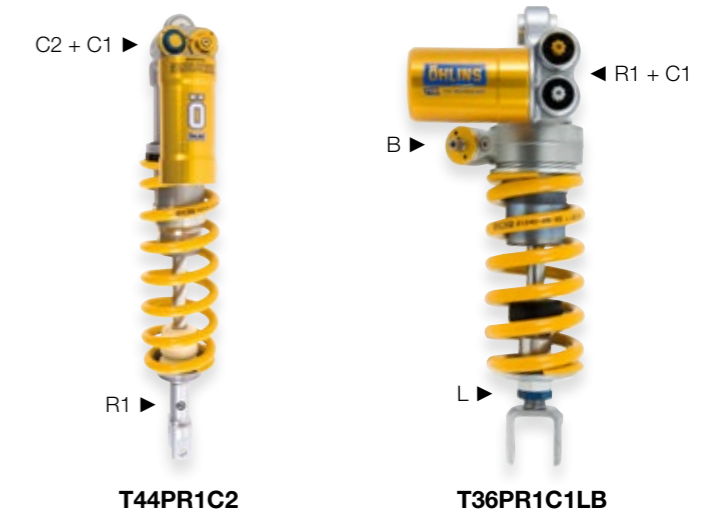

Öhlins manufactures more than 300 different shock absorber models, each model is tailor made for one specific bike. The concept of all Öhlins products is not a secret, it is precision. Precision provides superior control of the damping force and the key to our success.

## SHOCK ABSORBERS - TYPES & ADJUSTMENTS











Start with finding out which shock absorber fits your bike. Then, identify which type of shock absorber it is and which adjustment features it has according to the table below.



### SHOCK ABSORBER TYPE

-  **S, T**  
Single or twin tube design.
-  **30, 36, 39, 44, 46 and 50mm**  
Piston diameter
-  **E**  
Emulsion type of shock absorber.
-  **D**  
Monotube high pressure gas type of shock absorber with internal reservoir in the main body.
-  **P**  
Monotube high pressure gas type of shock absorber with external "piggy back" reservoir.
-  **H**  
Monotube high pressure gas type of shock absorber with hose mounted external reservoir.
-  **Q1**  
Progressive damping shock absorber with two pistons.
-  **W**  
Shock absorber delivered without spring.

### ADJUSTMENT FEATURES

-  **C1**  
Adjustable compression damping. Adjuster wheel or slot on the reservoir.
-  **C2**  
Adjustable high- and low- speed compression damping. Hexagon or slot on the reservoir.
-  **C4**  
Electronically Controlled (EC) compression damping adjuster.
-  **R1**  
Adjustable rebound damping. Adjuster wheel or slot above the end eye.
-  **R1**  
Adjustable rebound damping. Adjuster wheel or slot on the reservoir.
-  **R4**  
Electronically Controlled (EC) rebound damping adjuster.
-  **S**  
Hose mounted hydraulic spring preload adjuster.
-  **S1**  
Electronically Controlled (EC) hydraulic spring preload adjuster.
-  **B**  
Integrated hydraulic spring preload adjuster. Adjuster wheel or hexagon on the adjuster.
-  **L**  
Adjustable length.
-  Mechanical spring preload adjuster.







# ROAD&TRACK SHOCK ABSORBERS 2015

## TYPE S36



S36E S36D S36DR1L S36DW S36K

## TYPE T36P

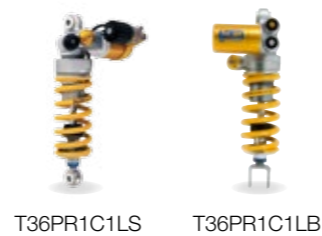

T36PR1C1LS T36PR1C1LB

## TYPE S36P

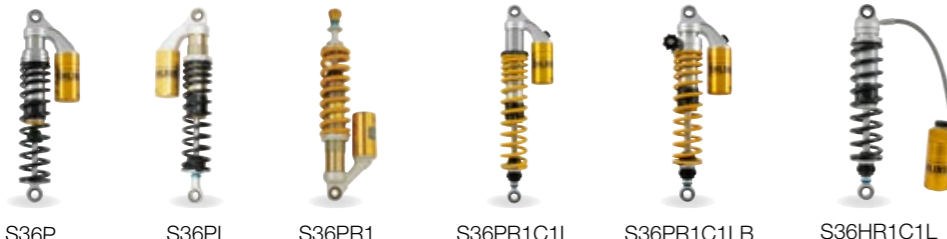

S36P S36PL S36PR1 S36PR1C1L S36PR1C1LB S36HR1C1L

## TYPE TTX39



T39PR4C4S1 T39PR1C1S

## TYPE TTX36

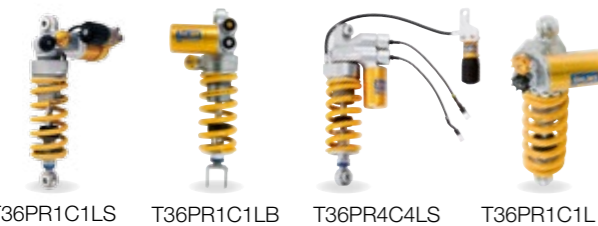

T36PR1C1LS T36PR1C1LB T36PR4C4LS T36PR1C1L

## TYPE S46

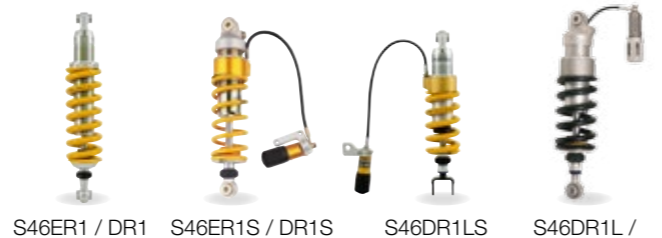

S46ER1 / DR1 S46ER1S / DR1S S46DR1LS S46DR1L / DR1LS CUSTOM

## TYPE S46H



S46HR1C1 S46HR1C1S S46HR1C1L S46HR1C1LS S46HR1C1B

## TYPE S46P

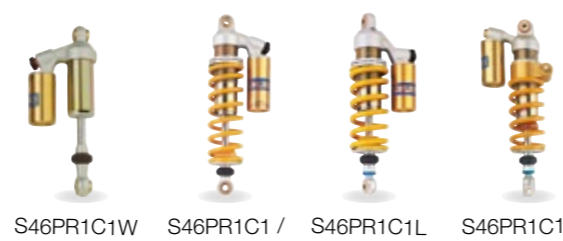

S46PR1C1W S46PR1C1 / S46PR1C1Q1 S46PR1C1L S46PR1C1LB

## TYPE S46P



S46PR1C1S S46PR1C1S S46PR1C1LS S46PR1C2 S46PR1C2L S46PR1C2B S46PR1C2S S46PR1C2LB S46PR1C2LS

Note! Your shock absorber may look different from the one on the image above. The reservoir may be angled to fit your bike and a horizontal reservoir is used on some models.

## TTX GP

This is the latest Öhlins shock absorber for sport and hypersport bikes. The already famous and high performing TTX shock goes to a new level with the latest valving technology from MotoGP. The TTX GP shock is now available for most bike models used in national racing as well as the latest street bikes.

- TTX technology, twin tube technology
- No risk of cavitation
- Solid piston
- Rebound and compression adjustment straight from MotoGP
- Adjustment needles with different flow restriction behavior to improve chassis feedback
- New main piston
- Wider and more precise adjustment range
- Adjustment possible by hand or with hexagon tool
- Completely separated functions for rebound and compression damping
- Easy to change settings, based on Öhlins setting bank



## TTX RT

The TTX Road & Track is developed for the latest hypersport models as a complement to the top of the line TTX GP shock. The TTX RT has a competitive price but still offers great performance for the road and track day enthusiast. The shock is based on the TTX36 with its race proven technology.

- TTX technology
- Wide adjuster range
- Completely separated functions for rebound and compression damping
- All adjustments are done on the cylinder head of the shock absorber
- Length adjustable for most models



## STX46

Öhlins product base rests on the successful 46 mm single tube shock absorber family. The settings are individually tested on each bike application to suit the bike model in particular. The shocks are also designed with different features depending on what we find most useful to the bike application. Comfort and performance in symbiosis, mixed with the traditional Öhlins values.

- Öhlins design
- Always individually tested on every bike application
- Full maintenance capability
- Setting library available through every Öhlins service center
- A wide range of spring rates available



## STX36

The smaller bikes and also motorcycles with twin shock absorbers usually have less space to fit a STX46 shock. Then the STX36 family is the perfect choice. We have them available in the cleanest design as well as fully adjustable with a lot of clickers and adjusters. It does not matter if you ride a Harley Touring bike or a scooter - We have a S36 shock available.

- Öhlins design
- Always individually tested on every bike application
- Full maintenance capability
- Setting library available through every Öhlins service center
- A wide range of spring rates available
- Spring colors in black, yellow and chrome available to all custom bikes and Harley Davidson



# SHOCK ABSORBERS

## ROAD&TRACK

Model	Year	Part No	Type Code	P/C	Length	Stroke	Spring	Notes
<b>APRILIA</b>								
RSV 1000 R	2004-09	AP 351	S46PR1C1LS	24	313 +3,5/-2,5	63,5	01093-31	
RSV 4	2009-15	AP 340	T36PR1C1LB	30	310 +6/-0	67	21040-31	TTX GP
RSV 4	2009-15	AP 360	T36PR1C1LB	30	310 +6/-0	67	21040-31	TTX GP
Tuono	2006-09	AP 351	S46PR1C1LS	24	313 +3,5/-2,5	63,5	01093-31	
<b>BMW</b>								
F 650 GS	2000-06	BM 344	S46ER1S	16	316	50	01092-74	
F 650 GS (2 cyl)	2008-12	BM 058	S46DR1	9	413,5	56,5	01092-69	
F 650 GS (2 cyl)	2008-12	BM 304	S46DR1S	16	413	51	01096-69	
F 650 GS Dakar	2000-07	BM 048	S46HR1C1S	23	328,5	60,5	01095-69	w/o ABS
F 700 GS	2013-14	BM 304	S46DR1S	16	413	51	01096-69	
F 800 GS	2008-14	BM 043	S46DR1	9	428,5	68,5	00698-69	
F 800 GS	2008-14	BM 303	S46HR1C1S	23	429	69	01096-69	
F 800 GS Adventure	2014-	BM 305	S46HR1C1B	23	429	69	01096-69	
F 800 R	2008-14	BM 059	S46DR1	9	350	53	01092-89	
F 800 S	2007-10	BM 706	S46DR1S	16	344,5	53,5	01092-89	
F 800 ST	2007-12	BM 706	S46DR1S	16	344,5	53,5	01092-89	
G 650 X Challenge	2007-09	BM 636	S46HR1C1	16	360	89	00698-39	
G 650 X Moto	2007-09	BM 633	S46HR1C1	16	343,5	72,5	01099-49	
HP 2 Enduro	2006	BM 688	S46PR1C2Q1	23	415,5	108,5	00580-24	
HP 4	2013-14	BM 343	T36PR1C1LB	30	353 +6/-0	62	21040-26	TTX GP Race use only
HP 4	2013-14	BM 360	T36PR1C1LB	30	353 +6/-0	62	21040-26	TTX GP Race use only
K 1200 GT	2003	BM 701	S36D	13	319	82	00180-58	Front
K 1200 LT	1999-03	BM 851	S46DR1S	16	400	55	01099-74	Rear
K 1200 LT	1999-08	BM 540	S36D	13	319	82	00180-56	Front
K 1200 LT	2004-08	BM 539	S46DR1S	16	400	55	01099-74	Rear
K 1200 R	2005-08	BM 445	S46DR1	12	323,5	54,5	01093-49	Front
K 1200 R	2005-08	BM 502	S46PR1C1S	26	334	78	01092-29	Rear
K 1200 R Sport	2007-08	BM 445	S46DR1	12	323,5	54,5	01093-49	Front
K 1200 R Sport	2007-08	BM 502	S46PR1C1S	26	334	78	01092-29	Rear
K 1200 RS	1997-03	BM 701	S36D	13	319	82	00180-58	Front
K 1200 RS	1997-06	BM 702	S46HR1C1LS	24	355 +12/-0	57	01093-59	Rear
K 1200 S	2005-08	BM 445	S46DR1	12	323,5	54,5	01093-49	Front
K 1300 GT	2008-10	BM 906	S46DR1	12	324,5	54,5	01093-49	Front
K 1300 GT	2008-11	BM 908	S46PR1C1S	26	336	80,5	01099-41	Rear
K 1300 R	2008-14	BM 502	S46PR1C1S	26	334	78	01092-29	Rear
K 1300 R	2008-14	BM 906	S46DR1	12	324,5	54,5	01093-49	Front
K 1300 S	2008-14	BM 906	S46DR1	12	324,5	54,5	01093-49	Front
R 100 CS	All	BM 141	S36P	13	338	103	00480-03	Rear
R 100 GS	1987-94	BM 051	S46DR1	9	495	80	00698-24	Rear
R 100 GS	1987-94	BM 541	S46PR1C1S	23	498,5	78,5	00698-24	Rear
R 100 GS	1987-94	BM 836	S46DR1S	16	495	80	00698-24	Rear
R 100 PD	1987-94	BM 051	S46DR1	9	495	80	00698-24	Rear
R 100 PD	1987-94	BM 541	S46PR1C1S	23	498,5	78,5	00698-24	Rear
R 100 PD	1987-94	BM 836	S46DR1S	16	495	80	00698-24	Rear
R 100 R	1992-95	BM 052	S46DR1	9	474	74	01096-24	Rear
R 100 R	1992-95	BM 332	S46DR1S	16	474	74	01096-24	Rear
R 100 RS	1985-93	BM 053	S46DR1	9	409	72	01096-21	Rear
R 100 RS	1985-93	BM 941	S46HR1C1	16	409	72	01096-21	Rear
R 100 RT	1981-86	BM 141	S36P	13	338	103	00480-03	Rear
R 100 RT	1985-93	BM 053	S46DR1	9	409	72	01096-21	Rear
R 100 RT	1985-93	BM 941	S46HR1C1	16	409	72	01096-21	Rear
R 100 S	All	BM 141	S36P	13	338	103	00480-03	Rear
R 1100 GS	1994-00	BM 425	S46ER1	13	335	92	01096-10	Front
R 1100 GS	1994-00	BM 054	S46DR1	9	383	63	01095-64	Rear
R 1100 GS	1994-99	BM 424	S46DR1S	16	383	63	01095-64	Rear

## ROAD&TRACK

# SHOCK ABSORBER

Model	Year	Part No	Type Code	P/C	Length	Stroke	Spring	Notes
R 1100 R	1995-00	BM 634	S46ER1	13	327	78	01096-10	Front
R 1100 R	1995-00	BM 635	S46DR1LS	20	358 +10/-2	57	01093-74	Rear
R 1100 RS	1993-01	BM 335	S46ER1	13	320	71	01096-10	Front
R 1100 RS	1993-01	BM 704	S46DR1S	16	358	57	01092-64	Rear
R 1100 RT	1996-01	BM 601	S46ER1	13	330	78	01096-10	Front
R 1100 RT	1996-01	BM 602	S46DR1LS	20	358 +10/-2	57	01093-74	Rear
R 1100 S	1998-04	BM 205	S46PR1C1LS	24	315 +12/-0	52	01093-59	Rear
R 1100 S	1999-04	BM 842	S36PR1	16	318	70	00180-44	Front
R 1150 GS	2000-03	BM 431	S46DR1SW	15	383	63		Rear
R 1150 GS	2000-03	BM 045	S46DR1	9	383	63	01095-54	Rear
R 1150 GS	2000-03	BM 425	S46ER1	13	335	92	01096-10	Front
R 1150 GS	2000-03	BM 542	S46HR1C1S	23	383	63,5	01095-54	Rear
R 1150 GS	2000-03	BM 940	S46DR1S	16	383	63	01095-54	Rear
R 1150 GS Adventure	2002-05	BM 215	S46DR1S	16	390	70	01095-54	Rear
R 1150 GS Adventure	2002-05	BM 216	S46ER1	13	344,5	101,5	01096-10	Front
R 1150 R	2001-06	BM 049	S46DR1S	16	366	56	01092-79	Rear
R 1150 R	2001-06	BM 050	S36DR1L	13	334 +6/-4	73	00180-44	Front
R 1150 R	2001-06	BM 061	S46DR1	9	366	56	01092-79	Rear
R 1150 RS	2002-04	BM 062	S46DR1	9	366	56	01092-69	Rear
R 1150 RS	2002-04	BM 335	S46ER1	13	320	71	01096-10	Front
R 1150 RT	2002-04	BM 124	S46ER1	13	330	78	01096-13	Front
R 1150 RT	2002-04	BM 125	S46DR1S	16	366	56	01092-69	Rear
R 1200 GS	2004-12	BM 044	S46DR1	9	403	78,5	00698-54	Rear
R 1200 GS	2004-12	BM 046	S46DR1	9	395	70,5	00698-54	Rear short
R 1200 GS	2004-12	BM 436	S46DR1S	16	403	78,5	00698-54	Rear
R 1200 GS	2004-12	BM 437	S46ER1	9	337	94	01096-10	Front
R 1200 GS	2004-12	BM 508	S46DR1S	16	395	70,5	00698-54	Rear short
R 1200 GS	2004-12	BM 509	S46ER1	9	325	82	01096-10	Front short
R 1200 GS	2004-12	BM 676	T39PR1C1S	29	402,5	75	01103-49	Rear
R 1200 GS K50	2013-14	BM 146	T39PR1C1S	29	402,5	75	01103-54	Rear Water cooled
R 1200 GS	2004-12	BM 677	T36PR1C1	17	340	90,5	21067-09	Front
R 1200 GS K50	2013-14	BM 147	T36PR1C1	17	392	88,5	21067-12	Front Water cooled
R 1200 GS	2008-12	BM 670	EC-kit	50				
R 1200 GS Adventure	2006-13	BM 047	S46DR1	9	409,5	85,5	01103-59	Rear
R 1200 GS Adventure	2006-13	BM 607	S46ER1	9	347	95	01096-12	Front
R 1200 GS Adventure	2006-13	BM 678	T39PR1C1S	29	410,5	83	01103-54	Rear
R 1200 GS Adventure K51	2014	BM 148	T39PR1C1S	29	408,5	81,5	01103-59	Rear Water cooled
R 1200 GS Adventure	2006-13	BM 679	T36PR1C1	17	350,5	100,5	21067-12	Front
R 1200 GS Adventure K51	2014	BM 149	T36PR1C1	17	399	97,5	21067-15	Front Water cooled
R 1200 GS Adventure	2008-13	BM 671	EC-kit	50				
R 1200 R	2007-10	BM 708	S46PR1C1LS	24	380 +12/-0	54	01092-79	Rear
R 1200 R	2007-10	BM 709	S36DR1L	13	327 +8/-2	73	00180-44	Front
R 1200 RT	2005-09	BM 503	S46ER1	13	330	78	01096-14	Front
R 1200 RT	2005-13	BM 504	S46DR1S	16	376	54	01092-69	Rear
R 1200 RT K52	2014	BM 438	S46DR1S	16	375	53	01096-69	Rear
R 1200 ST	2005-06	BM 505	S46ER1	13	288	64	01092-15	Front
R 50/5	All	BM 141	S36P	13	338	103	00480-03	Rear
R 60/5	All	BM 141	S36P	13	338	103	00480-03	Rear
R 60/6	All	BM 141	S36P	13	338	103	00480-03	Rear
R 75/6	All	BM 141	S36P	13	338	103	00480-03	Rear
R 80 GS	1980-87	BM 317	S46PR1C1	16	361	89	00698-19	Rear
R 80 GS	1988-94	BM 051	S46DR1	9	495	80	00698-24	Rear
R 80 GS	1988-94	BM 541	S46PR1C1S	23	498,5	78,5	00698-24	Rear
R 80 GS	1988-94	BM 836	S46DR1S	16	495	80	00698-24	Rear
R 80 R	1992-95	BM 052	S46DR1	9	474	74	01096-24	Rear
R 80 R	1992-95	BM 332	S46DR1S	16	474	74	01096-24	Rear

Accessories MX & Enduro Road & Track Front Road & Track Rear Scooter Performance Line Street Performance Line



# SHOCK ABSORBERS

## ROAD&TRACK

Model	Year	Part No	Type Code	P/C	Length	Stroke	Spring	Notes
<b>BMW</b>								
R 80 RS	1985-93	BM 053	S46DR1	9	409	72	01096-21	Rear
R 80 RS	1985-93	BM 941	S46HR1C1	16	409	72	01096-21	Rear
R 80 RT	1977-84	BM 141	S36P	13	338	103	00480-03	Rear
R 80 RT	1985-95	BM 053	S46DR1	9	409	72	01096-21	Rear
R 80 RT	1985-93	BM 941	S46HR1C1	16	409	72	01096-21	Rear
R 850 GS	1994-00	BM 054	S46DR1	9	383	63	01095-64	Rear
R 850 GS	1994-00	BM 424	S46DR1S	16	383	63	01095-64	Rear
R 850 GS	1994-00	BM 425	S46ER1	13	335	92	01096-10	Front
R 850 R	1996-02	BM 634	S46ER1	13	327	78	01096-10	Front
R 850 R	1996-02	BM 635	S46DR1LS	20	358 +10/-2	57	01093-74	Rear
R 850 R	2003-06	BM 049	S46DR1S	16	366	56	01092-79	Rear
R 850 R	2003-06	BM 050	S36DR1L	13	334 +6/-4	73	00180-44	Front
R 850 R	2003-06	BM 061	S46DR1	9	366	56	01092-79	Rear
R 90 S	All	BM 141	S36P	13	338	103	00480-03	Rear
R 90/6	All	BM 141	S36P	13	338	103	00480-03	Rear
R nine T	2014-15	BM 440	S46PR1C1B	24	368	46	01093-64	Rear
S 1000 R	2014	BM 345	T36PR1C1LB	30	335 +4/-2	62	21040-21	TTX GP
S 1000 R	2014	BM 365	T36PR1C1LB	30	335 +4/-2	62	21040-21	TTX GP
S 1000 RR	2010-11	BM 931	T36PR1C1LB	29	314 +3/-3	62	21040-26	MKII
S 1000 RR	2010-11	BM 342	T36PR1C1LB	30	314 +3/-3	62	21040-26	TTX GP
S 1000 RR	2010-11	BM 362	T36PR1C1LB	30	314 +3/-3	62	21040-26	TTX GP
S 1000 RR	2012-14	BM 340	T36PR1C1LB	30	310 +5/-1	62	21040-26	TTX GP. Not HP4
S 1000 RR	2012-14	BM 361	T36PR1C1LB	30	310 +5/-1	62	21040-26	TTX GP. Not HP4
S 1000 RR	2012-14	BM 358	T36PR1C1L	23	310 +5/-1	62	21040-26	Not HP4
S 1000 RR	2015	BM 360	T36PR1C1LB	30	353 +6/-0	62	21040-26	Not for bike with DDC-system
<b>BUELL</b>								
1125CR	2009	BU 888	T36PR1C1LS	30	321 +6/-0	58	21040-39	
1125R	2008-09	BU 888	T36PR1C1LS	30	321 +6/-0	58	21040-39	
XB12R Firebolt	2004-09	BU 201	S46HR1C1LS	24	358 +11/-1	78	01092-24	
XB9R Firebolt	2002-09	BU 201	S46HR1C1LS	24	358 +11/-1	78	01092-24	
<b>DUCATI</b>								
748	1994-02	DU 143	S46PR1C2B	27	305	71	01091-19	
749	2003-05	DU 301	S46PR1C2B	26	305	71	01091-24	
848	2008-13	DU 931	T36PR1C1B	29	294,5	60	21040-24	MKII
899 Panigale	2014-15	DU 339	T36PR1C1L	28	312 +4/-8	65	01092-24	TTX GP
899 Panigale	2014-15	DU 361	T36PR1C1L	28	312 +4/-8	65	01092-24	TTX GP
916	1994-00	DU 143	S46PR1C2B	27	305	71	01091-19	
996	1999-01	DU 143	S46PR1C2B	27	305	71	01091-19	
998	2002-03	DU 143	S46PR1C2B	27	305	71	01091-19	
999	2003-05	DU 301	S46PR1C2B	26	305	71	01091-24	
1098	2008-09	DU 931	T36PR1C1B	29	294,5	60	21040-24	MKII
1198	2009-12	DU 931	T36PR1C1B	29	294,5	60	21040-24	MKII
1199 Panigale	2012-15	DU 340	T36PR1C1L	28	312 +4/-8	65	01092-29	TTX GP
1199 Panigale	2012-15	DU 360	T36PR1C1L	28	312 +4/-8	65	01092-29	TTX GP
750 Sport	2001-02	DU 235	S46PR1C1L	17	328 +12/-0	68	01092-26	
750 SS	1991-02	DU 235	S46PR1C1L	17	328 +12/-0	68	01092-26	
900 SL	1991-99	DU 235	S46PR1C1L	17	328 +12/-0	68	01092-26	
900 Sport	2002	DU 235	S46PR1C1L	17	328 +12/-0	68	01092-26	
900 SS	1991-02	DU 235	S46PR1C1L	17	328 +12/-0	68	01092-26	
Diavel	2001-14	DU 110	S46HR1C1S	24	295,5	58,5	01092-24	
MH900e	2001-02	DU 106	S46PR1C1L	17	325 +3,5/-2,5	84,5	01092-04	
Monster 1000	2003-05	DU 046	S46PR1C1S	23	305	66	01091-34	
Monster 1000	2003-05	DU 321	S46DR1	9	305	66	01091-34	
Monster 1100	2009-13	DU 737	S46DR1	9	294,5	58,5	01092-41	
Monster 600	1994-01	DU 044	S46DR1	9	330	65	01091-31	

## ROAD&TRACK

Model	Year	Part No	Type Code	P/C	Length	Stroke	Spring	Notes
Monster 600	1994-01	DU 440	S46HR1C1	16	330	65	01091-31	
Monster 620	2002-05	DU 046	S46PR1C1S	23	305	66	01091-34	
Monster 620	2002-05	DU 321	S46DR1	9	305	66	01091-34	
Monster 696	2008-12	DU 737	S46DR1	9	294,5	58,5	01092-41	
Monster 750	2002	DU 046	S46PR1C1S	23	305	66	01091-34	
Monster 750	2002	DU 321	S46DR1	9	305	66	01091-34	
Monster 750	1994-01	DU 044	S46DR1	9	330	65	01091-31	
Monster 750	1994-01	DU 440	S46HR1C1	16	330	65	01091-31	
Monster 795/796	2014	DU 432	S46HR1C1	11	295	58	60017-41	
Monster 796	2011-12	DU 737	S46DR1	9	294,5	58,5	01092-41	
Monster 800	2003-05	DU 046	S46PR1C1S	23	305	66	01091-34	
Monster 800	2003-05	DU 321	S46DR1	9	305	66	01091-34	
Monster 900	2002	DU 046	S46PR1C1S	23	305	66	01091-34	
Monster 900	2002	DU 321	S46DR1	9	305	66	01091-34	
Monster 900	1994-01	DU 044	S46DR1	9	330	65	01091-31	
Monster 900	1994-01	DU 440	S46HR1C1	16	330	65	01091-31	
Monster S2R 1000	2005	DU 321	S46DR1	9	305	66	01091-34	
Monster S2R 800	2005	DU 321	S46DR1	9	305	66	01091-34	
Monster S4	2001-05	DU 046	S46PR1C1S	23	305	66	01091-34	
Monster S4	2001-05	DU 321	S46DR1	9	305	66	01091-34	
Monster S4R	2003-05	DU 333	S46HR1C1S	23	305	65	01092-31	
Multistrada	2010-14	DU 868	T36PR1C1S	30	345	70	21729-34	
Multistrada	2010-12	DU 871	EC-kit	54				
ST 2	1997-00	DU 701	S46HR1C1S	23	305	63	01091-31	
ST 3	2003-07	DU 701	S46HR1C1S	23	305	63	01091-31	
ST 4	1997-00	DU 701	S46HR1C1S	23	305	63	01091-31	
Street Fighter	2009-13	DU 816	T36PR1C1B	29	294,5	60	21042-24	
Street Fighter S	2009-13	DU 816	T36PR1C1B	29	294,5	60	21042-24	
<b>HONDA</b>								
Ape 50/100		HO 511	S36HR1C1L	15	263 +2,5/-2,5	38	00281-39	
Ape 50/100		HO 513	S36E	5	261	38	00281-38	
CB 1000 BIG	1993-97	HO 143	S36P	13	356,5	92	00480-03	
CB 1000 R	2008-14	HO 009	S46DR1	9	310	47	01095-64	
CB 1000 R	2008-14	HO 808	S46HR1C1S	23	309,5	47,5	01093-64	
CB 1100	2010-11	HO 010	S36DR1L	20	362 +5/-5	83	00480-03 (B)	
CB 1100	2010-11	HO 011	S36DR1L	20	362 +5/-5	83	21211-03 (C)	
CB 1100 F	1982-85	HO 140	S36P	13	364	97	00480-03	
CB 1100 F	1982-85	HO 153E	S36E	9	365	98	00480-03	
CB 1100 R	1981-84	HO 140	S36P	13	364	97	00480-03	
CB 1100 R	1981-84	HO 153E	S36E	9	365	98	00480-03	
CB 1300	1999-01	HO 147	S36PR1C1LB	30	310 +10/-0	71	00180-57	
CB 1300	2003-11	HO 414	S36PR1C1L	30	365 +8/-2	92	00480-23 (B)	
CB 1300	2003-11	HO 417	S36PR1C1L	30	365 +8/-2	92	00480-33 (Y)	
CB 400 Super Four	1992-93	HO 142	S36P	13	330	88	00480-02	
CB500F	2013-14	HO 320	S46DR1	6	150	54	61093-39	
CB 600F Hornet	1998-04	HO 321	S46DR1	9	303	53,5	01093-64	
CB 600F Hornet	1998-04	HO 541	S46HR1C1L	17	304 +11,5/-0,5	53,5	01093-64	
CB 600F Hornet	2005-06	HO 155	S46DR1	9	306	53	01093-64	
CB 650F	2013-	HO 428	S46DR1	9	331	49	60016-69	
CB 750 F	1980-84	HO 140	S36P	13	364	97	00480-03	
CB 750 F	1980-84	HO 153E	S36E	9	365	98	00480-03	
CB 750 KZ	1979-84	HO 140	S36P	13	364	97	00480-03	
CB 750 KZ	1979-84	HO 153E	S36E	9	365	98	00480-03	
CB 750 Seventy	1992-94	HO 141	S36P	13	356,5	98	00480-02	
CB 900	1979-84	HO 140	S36P	13	364	97	00480-03	
CB 900	1979-84	HO 153E	S36E	9	365	98	00480-03	
CB 900F Hornet	2002-06	HO 201	S46HR1C1S	23	283	50,5	01093-74	

Road & Track Rear  
Scooter Performance Line  
Street Performance Line  
Road & Track Front  
HD & Custom  
Mechanics  
MX & Enduro  
Accessories

# SHOCK ABSORBERS

## ROAD&TRACK

Model	Year	Part No	Type Code	P/C	Length	Stroke	Spring	Notes
<b>HONDA</b>								
CB 900F Hornet	2002-06	HO 322	S46DR1	9	283	50,5	01093-74	
CBF 1000	2006-09	HO 044	S46DR1	9	293,5	51,5	01093-69	
CBF 600 SA	2008-11	HO 809	S46DR1S	16	310	45,5	01092-84	
CBR 1000 RR	2004-05	HO 347	S46PR1C2LS	30	314 +6/-0	58	01093-39	
CBR 1000 RR	2006-07	HO 604	S46PR1C2LS	30	314 +6/-0	58	01093-44	
CBR 1000 RR	2008-15	HO 358	T36PR1C1L	23	302 +4/-2	60	21040-36	TTX RT With and w/o ABS
CBR 1000 RR	2008-15	HO 360	T36PR1C1LS	30	302 +4/-2	60	21040-36	TTX GP With and w/o ABS
CBR 1100 XX	1997-00	HO 639	S46HR1C1S	23	319	52	01092-69	
CBR 1100 XX	2001-06	HO 518	S46HR1C1S	23	319	52	01092-69	
CBR 250 R	2011-12	HO 122	S36D	6	297	54	00281-17	
CBR 250 R	2012-14	HO 426	S36DR1	4	297	54	60281-11	
CBR 500R	2013-14	HO 320	S46DR1	6	307	54	61093-39	
CBR 600 RR	2005-06	HO 502	S46PR1C2LS	30	310,5 +3/-3	59,5	01093-31	
CBR 600 RR	2007-15	HO 339	T36PR1C1LS	30	295 +6/-0	60	21040-31	TTX GP w/o ABS
CBR 600 RR	2007-15	HO 361	T36PR1C1LS	30	295 +6/-0	60	21040-31	TTX GP w/o ABS
CBR 600 RR	2009-11	HO 889	T36HR1C1LS	27	295 +6/-0	60	21040-31	MKI ABS
CBR 600 RR	2009-13	HO 039	T36HR1C1LS	29	295 +6/-0	60	21040-31	MKII ABS
CBR 650R	2013-	HO 428	S46DR1	9	331	49	60016-69	
CBR 900 RR	1998-99	HO 802	S46HR1C1L	17	303 +12/-0	57	01093-59	
CBX 1000	1978-81	HO 140	S36P	13	364	97	00480-03	
CBX 1000	1978-81	HO 153E	S36E	9	365	98	00480-03	
CRF 250L		HO 429	S46HR1C1	11	396	82	60011-36	
Foresight FEZ 250	1998-02	HO 839	S36E	5	400	125	00480-11	
NC 700 X	2012-13	HO 070	S46DR1	9	312	56,5	01095-54	
NSR 250 R-SE	1990-93	HO 206	S46HR1C1L	17	302 +6/-6	50	01093-49	
NSR 250 R-SP	1994-00	HO 206	S46HR1C1L	17	302 +6/-6	50	01093-49	
NSR Mini		HO 890	T36PR1C1L	25	218 +4/-2	35	21140-71	
RC 51	2002-06	HO 204	S46PR1C2LS	30	326 +10/-2	63	01092-29	
VFR 1200 F	2010-14	HO 013	S46HR1C1S	23	321,5	50,5	01092-74	
VFR 800 FI	2002-12	HO 043	S46DR1	9	317,5	53,5	01092-69	
VFR 800 FI	2002-12	HO 203	S46DR1S	16	317,5	53,5	01092-69	
VFR 800 FI	2002-12	HO 605	S46HR1C1LS	24	317,5 +6/-0	54,5	01092-69	
VTR 1000 F	1997-07	HO 701	S46HR1C1S	23	346	60	01092-64	
VTR 1000 SP1	2000-01	HO 204	S46PR1C2LS	30	326 +10/-2	63	01092-29	
VTR 1000 SP2	2002-06	HO 204	S46PR1C2LS	30	326 +10/-2	63	01092-29	
VTR 250	2009	HO 944	S36D	3	295	48	00281-36	
XL 1000 V Varadero	1999-02	HO 046	S46DR1	9	338	65	01095-54	
XL 1000 V Varadero	2003-12	HO 045	S46DR1	9	334	55	01095-69	
XL 1000 V Varadero	2003-12	HO 533	S46HR1C1S	23	334	55	01095-69	
XL 600V	1988-90	HO 836	S46ER1	9	355	83	01096-44	
XL 700 V Transalp	2008-12	HO 823	S46ER1S	16	316,5	65,5	01092-59	
XRV 750 Africa Twin	1993-02	HO 645	S46HR1C1S	23	380	90	01096-26	
<b>HUSQVARNA</b>								
Nuda 900	2012	HA 137	S46PR1C1L	16	380,5 +11,5-0,5	65,5	01096-34	
<b>KAWASAKI</b>								
ER-6 N/F	2009-14	KA 037	S46DR1	9	282	49,5	01093-74	Low version
ER-6 N/F	2009-14	KA 906	S46DR1	9	290	51,5	01093-69	With and w/o ABS
GPZ 500	1980-85	KA 143	S36P	13	344	92	00480-02	
GPZ 900 R	1984-98	KA 449	S46HR1C1LS	24	310,5 +12/-0	57	01093-21	
GPZ 900 R	1984-98	KA 543	S46ER1S	16	310	67	01091-21	
GPZ 900 R	1999-00	KA 914	S46HR1C1LS	24	315 +12/-0	66	01091-26	
GPZ 900 Racing	1984-98	KA 634	S46HR1C1LS	24	325 +12/-0	62	01091-21	
GPZ 900 Racing	1999-00	KA 203	S46HR1C1LS	24	330 +10/-2	67,5	01091-29	17 inch rear wheel

## ROAD&TRACK

# SHOCK ABSORBER

Model	Year	Part No	Type Code	P/C	Length	Stroke	Spring	Notes
GTR 1400	2008-09	KA 709	S46PR1C1S	25	355,5	70,5	01095-49	
GTR 1400	2010-14	KA 109	S46PR1C1S	25	355,5	70,5	01095-49	
KLX 250	2013-14	KA 426	S46PR1C1	9	425	95	60012-11	
KSR 110		KA 607	S36HR1C1L	15	235 +7/-3	34	00282-05	
Ninja 250R	2009-11	KA 840	S36HR1C1L	15	320 +6/-2	63	00281-57	
Ninja 300	2013	KA 841	S36HR1C1L	15	320 +6/-2	63	00281-57	
Ninja 400R	2010	KA 041	S36D	5	284	41	00281-36	
Street Line		KA 216	S36E	9	347	92	00480-02	
Street Line		KA 756	S36DR1L	13	347 +10/-0	88	00480-02	
W 650	1999-09	KA 224	S36D	9	325	93	00360-04	
W400/650	1999-03	KA 632	S36E	9	296	71	00360-05	Short version
Versys	2006-13	KA 907	S46DR1	9	301,5	51,5	01093-69	With and w/o ABS
Versys 1000	2012-14	KA 126	S46DR1S	16	364,5	76,5	01096-24	
Z 1000	1977-85	KA 140	S36P	13	347	92	00480-03	
Z 1000	1977-85	KA 146	S36PR1C1LB	30	347 +10/-0	92	00480-13	
Z 1000	1977-85	KA 246	S36PR1C1LB	30	347 +10/-0	92	00480-03 (B)	
Z 1000	2003-06	KA 155	S46DR1	9	338	60	01095-34	
Z 1000	2007-09	KA 734	S46PR1C2LS	30	332,5 +12/-0	67	01091-34	
Z 1000	2010-13	KA 010	S46DR1S	16	356,5	61,5	01092-26	
Z 1000	2010-13	KA 043	S46DR1	9	356,5	61,5	01092-26	
Z 1000	2014	KA 434	S46DR1S	16	351	61	01092-26	
Z 1000 SX	2011-14	KA 110	S46DR1S	16	356	61	01091-34	
Z 400 J	1980-87	KA 143	S36P	13	344	92	00480-02	
Z 400 J	1980-87	KA 147	S36PR1C1LB	30	344 +10/-0	92	00480-12	
Z 400 J	1980-87	KA 747	S36PR1C1L	30	344 +10/-0	89	00480-12	
Z 500	1980-85	KA 143	S36P	13	344	92	00480-02	
Z 500	1980-85	KA 147	S36PR1C1LB	30	344 +10/-0	92	00480-12	
Z 500	1980-85	KA 747	S36PR1C1L	30	344 +10/-0	89	00480-12	
Z 500 GP	1980-85	KA 147	S36PR1C1LB	30	344 +10/-0	92	00480-12	
Z 500 GP	1980-85	KA 747	S36PR1C1L	30	344 +10/-0	89	00480-12	
Z 750	2004-06	KA 044	S46DR1	9	328	68	01091-31	
Z 750	2007-08	KA 009	S46DR1	9	332	63	01096-31	
Z 750 GP	1982-86	KA 140	S36P	13	347	92	00480-03	
Z 750 GP	1982-86	KA 146	S36PR1C1LB	30	347 +10/-0	92	00480-13	
Z 750 GP	1982-86	KA 246	S36PR1C1LB	30	347 +10/-0	92	00480-03 (B)	
Z 750 L	1982-85	KA 143	S36P	13	344	92	00480-02	
Z 750 L	1982-85	KA 147	S36PR1C1LB	30	344 +10/-0	92	00480-12	
Z 750 L	1982-85	KA 747	S36PR1C1L	30	344 +10/-0	89	00480-12	
Z 750 R	2011-12	KA 105	T36PR1C1L	27	334+3/-3	70	21040-24	
Z 750 S	2005	KA 044	S46DR1	9	328	68	01091-31	
Z 750 Sport	1982-85	KA 143	S36P	13	344	92	00480-02	
Z 750 Sport	1982-85	KA 147	S36PR1C1LB	30	344 +10/-0	92	00480-12	
Z 750 Sport	1982-85	KA 747	S36PR1C1L	30	344 +10/-0	89	00480-12	
Z 900	1973-76	KA 140	S36P	13	347	92	00480-03	
Z 900	1973-76	KA 146	S36PR1C1LB	30	347 +10/-0	92	00480-13	
Z 900	1973-76	KA 246	S36PR1C1LB	30	347 +10/-0	92	00480-03 (B)	
Zephyr 1100	1992-01	KA 140	S36P	13	347	92	00480-03	
Zephyr 1100	1992-01	KA 146	S36PR1C1LB	30	347 +10/-0	92	00480-13	
Zephyr 1100	1992-01	KA 246	S36PR1C1LB	30	347 +10/-0	92	00480-03 (B)	
Zephyr 1100	1992-01	KA 446	S36PR1C1L	30	347 +10/-0	92	00480-23 (B)	
Zephyr 1100	1992-01	KA 448	S36PR1C1L	30	347 +10/-0	92	00480-33 (Y)	
Zephyr 400	1991-99	KA 143	S36P	13	344	92	00480-02	
Zephyr 400 / 750	1991-99	KA 147	S36PR1C1LB	30	344 +10/-0	92	00480-12	
Zephyr 400 / 750	1991-99	KA 747	S36PR1C1L	30	344 +10/-0	89	00480-12	
Zephyr 750	1991-99	KA 143	S36P	13	344	92	00480-02	
ZRX 1100	1997-99	HO 417	S36PR1C1L	30	365 +8/-2	92	00480-33 (Y)	

Accessories MX & Enduro Road & Track Front Street Performance Line Scooter Performance Line Road & Track Rear

# SHOCK ABSORBERS

## ROAD&TRACK

Model	Year	Part No	Type Code	P/C	Length	Stroke	Spring	Notes
<b>KAWASAKI</b>								
ZRX 1100	1997-99	KA 151	S36PR1C1LB	30	365 +8/-2	94	00480-13	
ZRX 1200	2001-05	KA 149	S36PR1C1LB	30	365 +8/-2	94	00480-33	
ZRX 1200	2001-05	KA 249	S36PR1C1LB	30	365 +8/-2	94	00480-23 (B)	
ZRX 1200	2001-05	KA 416	S36PR1C1L	30	365 +8/-2	92	00480-23 (B)	
ZRX 1200	2001-05	KA 417	S36PR1C1L	30	365 +8/-2	92	00480-33 (Y)	
ZRX 400	1994-96	KA 141	S36P	13	360,5	96	00480-02	
ZX 10 R	2004-05	KA 345	S46PR1C2LS	30	338 +7/-5	69	01091-31	
ZX 10 R	2008-10	KA 788	T36PR1C1LS	27	338 +5/-1	64	21040-29	MKI
ZX 10 R	2011-12	KA 035	T36PR4C4LS	34	309+6/-0	59	21040-39	EC-type
ZX 10 R	2011-15	KA 358	T36PR1C1L	23	309+6/-0	59	21040-39	
ZX 10 R	2011-15	KA 340	T36PR1C1LS	30	309+6/-0	59	21040-39	TTX GP
ZX 10 R	2011-15	KA 360	T36PR1C1LS	30	309+6/-0	59	21040-39	TTX GP
ZX 10 R	2013-15	KA 040	T36PR4C4LS	34	309+6/-0	59	21040-39	EC-type
ZX 12 R	2002-05	KA 209	S46PR1C1LS	26	338 +12/-0	67	01092-34	
ZX 6 R	2007	KA 646	S46PR1C2LS	30	340 +5/-1	64	01093-29	
ZX 6 R	2007-08	KA 789	T36PR1C1LS	27	340 +6/-0	67	21040-31	MKI
ZX 6 R (600cc)	2009-15	KA 336	T36PR1C1LS	30	341 +2/-4	64	21040-31	TTX GP
ZX 6 R (600cc)	2009-15	KA 361	T36PR1C1LS	30	341 +2/-4	64	21040-31	TTX GP
ZX 6 R (636 cc)	2013-15	KA 338	T36PR1C1LS	30	341 +2/-4	64	21040-36	TTX GP
ZX 6 R (636 cc)	2013-15	KA 362	T36PR1C1LS	30	341 +2/-4	64	21040-36	TTX GP
ZZ-R 1100	1990-92	KA 003	S46HR1C1S	23	314,5	67	01091-26	
ZZ-R 1100	1993-99	KA 309	S46HR1C1S	23	338	67	01096-29	
ZZ-R 1400	2006-14	KA 046	S46DR1	9	330	65	01091-31	
ZZ-R 1400	2006-14	KA 544	S46HR1C1LS	24	329 +7/-5	65	01091-31	
ZZ-R 1400	2006-14	KA 128	T39PR1C1S	29	330	63	01092-41	
<b>KTM</b>								
125/200 Duke	2013	KT 301	S46DR1	9	300	63	01091-34	
390 Duke	2014	KT 301	S46DR1	9	300	63	01091-34	
690 Enduro R	2009-11	KT 122	S46PR1C1	17	406	100,5	00580-19	
690 Enduro R	2012-13	KT 123	S46PR1C1	17	397,5	87,5	00580-21	
1290 Super Duke	2014	KT 302	T36PR1C1B	28	384	58	01092-69	
<b>MV AGUSTA</b>								
F4	2010-14	MV 931	T36PR1C1	26	325,5	77	21042-18	MKII
<b>SUZUKI</b>								
DL 1000 V-Strom	2002-08	SU 201	S46PR1C1S	25	345	75,5	01096-34	
DL 1000 V-Strom	2002-08	SU 508	S46DR1	9	345	75,5	01096-34	
DL 650 V-Strom	2004-11	SU 823	S46DR1S	16	340,5	71,5	01096-31	
DL 650 V-Strom	2004-14	SU 043	S46DR1	9	340,5	71,5	01096-31	
DL 650 V-Strom	2012-14	SU 216	S46DR1S	16	340,5	71,5	01096-31	
DR-Z 400SM	2005-07	SU 506	S46PR1C2	17	447	124,5	00596-13	
GS 1000 E / H	1979-82	SU 143	S36P	13	331	83	00480-03	
GS 1000 L / S	1979-82	SU 143	S36P	13	331	83	00480-03	
GS 750 E	1977-84	SU 143	S36P	13	331	83	00480-03	
GS 750 L	1977-81	SU 143	S36P	13	331	83	00480-03	
GS 750 S	1979-84	SU 143	S36P	13	331	83	00480-03	
GSF 1200 Bandit	1996-00	SU 601	S46HR1C1S	23	306	64	01091-29	
GSF 1200 Bandit	2001-05	SU 322	S46DR1	9	320	56	01095-44	
GSF 1250 Bandit	2007-14	SU 045	S46DR1	9	320	64	01092-49	With and w/o ABS
GSF 1250 Bandit S/SA/A	2007-14	SU 103	S46HR1C1S	23	320	60,5	01092-59	With and w/o ABS
GSF 600 Bandit	2000-04	SU 321	S46DR1	9	319	55	01091-39	
GSF 650 Bandit	2005-06	SU 504	S46DR1S	16	319,5	65,5	01095-31	
GSR 600	2006-09	SU 046	S46DR1	9	337	68	01091-29	
GSR 750	2011-12	SU 120	S46PR1C2	18	326,5	68	01092-34	
GSR 750	2011-14	SU 121	S46DR1	9	327,5	68,5	01092-34	
GSX 1100	1979-83	SU 143	S36P	13	331	83	00480-03	

## ROAD&TRACK

# SHOCK ABSORBER

Model	Year	Part No	Type Code	P/C	Length	Stroke	Spring	Notes
GSX 1100 Katana	1981-83	SU 143	S36P	13	331	83	00480-03	
GSX 1100 R	1986-88	SU 635	S46HR1C1	16	315	69	01095-21	
GSX 1100 R	1990-92	SU 002	S46HR1C1	16	312	70	01092-29	
GSX 1250 F/FA	2010-14	SU 103	S46HR1C1S	23	320	60,5	01092-59	With and w/o ABS
GSX 1300 R Hayabusa	1999-07	SU 406	S46PR1C2LS	30	330 +10/-0	68	01092-41	
GSX 1300 R Hayabusa	2008-12	SU 026	T36PR1C1LS	30	330 +4/-2	65	01095-54	
GSX 1300 R Hayabusa	2008-12	SU 717	S46PR1C1LS	26	330 +5/-1	67,5	01095-54	
GSX 1400	2001-07	SU 133	S36PR1C1LB	30	328 +10/-0	91	00380-06	
GSX-R 1000	2005-06	SU 503	S46PR1C2LS	30	325,5 +6/-0	70	01093-29	
GSX-R 1000	2007-08	SU 932	T36PR1C1LB	29	315 +2/-2	63	21040-36	MKII
GSX-R 1000	2009-15	SU 888	T36PR1C1LB	27	320 +4/-2	63	21040-31	MKI
GSX-R 1000	2009-15	SU 931	T36PR1C1LB	29	320 +4/-2	63	21040-31	MKII
GSX-R 1000	2009-15	SU 358	T36PR1C1L	23	320 +4/-2	63	21040-31	
GSX-R 1000	2009-15	SU 340	T36PR1C1LB	30	320 +4/-2	63	21040-31	TTX GP
GSX-R 1000	2009-15	SU 360	T36PR1C1LB	30	320 +4/-2	63	21040-31	TTX GP
GSX-R 600	2011-15	SU 037	T36PR1C1LB	27	319 (+2/-4)	65	21040-31	MKI
GSX-R 600	2004-05	SU 347	S46PR1C2LS	30	332,5 +6/0	74	01091-26	
GSX-R 600	2006-10	SU 789	T36PR1C1LB	27	320 +3/-3	63	21040-29	MKI
GSX-R 600	2011-15	SU 357	T36PR1C1L	23	319 (+2/-4)	65	21040-31	
GSX-R 600	2011-15	SU 339	T36PR1C1LB	30	319 (+2/-4)	65	21040-31	TTX GP
GSX-R 600	2011-15	SU 361	T36PR1C1LB	30	319 (+2/-4)	65	21040-31	TTX GP
GSX-R 750	2011-15	SU 037	T36PR1C1LB	27	319 (+2/-4)	65	21040-31	MKI
GSX-R 750	2004-05	SU 347	S46PR1C2LS	30	332,5 +6/0	74	01091-26	
GSX-R 750	2006-10	SU 789	T36PR1C1LB	27	320 +3/-3	63	21040-29	MKI
GSX-R 750	2011-15	SU 357	T36PR1C1L	23	319 (+2/-4)	65	21040-31	
GSX-R 750	2011-15	SU 339	T36PR1C1LB	30	319 (+2/-4)	65	21040-31	TTX GP
GSX-R 750	2011-15	SU 361	T36PR1C1LB	30	319 (+2/-4)	65	21040-31	TTX GP
RE-5	1975-77	SU 143	S36P	13	331	83	00480-03	
RE-5	1975-77	SU 145	S36PR1C1LB	30	330,5 +10/-0	83	00380-05	
RGV 250	1989-93	SU 904	S46HR1C1L	17	307 +5/-7	55	01093-19	
SV 650	2003-07	SU 323	S46DR1	9	330	70	01096-21	w/o ABS
SV 650	2003-07	SU 606	S46PR1C1L	17	330 +12/-0	70	01096-21	w/o ABS
TL 1000 R	1998-01	SU 806	S46PR1C1	24	253	49	01093-89	
TL 1000 S	1997-98	SU 805	S46PR1C1W	17	280	50	x	
<b>TRIUMPH</b>								
Bonneville	2001-14	TR 326	S36E	9	341	101	00480-03	
Daytona 675 and 675 R	2006-12	TR 339	T36PR1C1LS	30	293 +6/-0	58	21040-34	TTX GP
Daytona 675 and 675 R	2006-12	TR 362	T36PR1C1LS	30	293 +6/-0	58	21040-34	TTX GP
Daytona 675 and 675 R	2013-15	TR 338	T36PR1C1LB	30	295,5 +5,5/-0,5	60	21040-34	TTX GP
Daytona 675 and 675 R	2013-15	TR 361	T36PR1C1LB	30	295,5 +5,5/-0,5	60	21040-34	TTX GP
Scrambler	2006-08	TR 538	S36DR1L	20	375 +10/-0	101	00480-03	
Scrambler		TR 927	S36PL	16	369+10/-0	100	00480-03	
Speed Triple	2005-06	TR 502	S46HR1C1LB	23	371 +12/-0	61,5	01095-54	
Speed Triple 1050	2008-10	TR 045	S46DR1	9	370,5	60,5	01095-54	
Speed Triple 1050	2011-14	TR 105	T36PR1C1	26	293,5	61,5	21141-34	MKI
Sprint ST	2006-09	TR 703	S46PR1C1LS	24	350 +6/-0	53,5	01095-54	
Street Triple 675	2008-12	TR 043	S46DR1	9	290	56	01093-44	
Street Triple 675 / and R	2008-12	TR 805	S46PR1C1L	19	290,5 +6/-0	57,5	01093-44	
Street Triple R 675	2009-12	TR 805	S46PR1C1L	19	290,5 +6/-0	57,5	01093-44	
Street Triple R 675	2009-12	TR 043	S46DR1	9	290	56	01093-44	
Thrupton	2005-14	TR 538	S36DR1L	20	375 +10/-0	101	00480-03	
Tiger 1050	2007-12	TR 044	S46DR1	9	350	62,5	01095-44	
Tiger 1050	2007-12	TR 704	S46HR1C1B	23	350	62,5	01095-44	
Tiger 800	2011-14	TR 119	S46HR1C1S	23	345,5	68	01096-31	
Tiger 800 XC	2011-14	TR 120	S46HR1C1S	23	360,5	83	01096-31	

Road & Track Rear  
Scooter Performance Line  
Street Performance Line  
Road & Track Front  
HD & Custom  
Mechanics  
MX & Enduro  
Accessories



# SHOCK ABSORBERS

ROAD&TRACK

ROAD&TRACK

# SHOCK ABSORBER

Model	Year	Part No	Type Code	P/C	Length	Stroke	Spring	Notes
<b>YAMAHA</b>								
Bolt	2014	YA 357	S36PR1C1L	20	255	50	60281-27	
FJR 1300	2001-05	YA 056	S46DR1	9	325	61	01092-34	With and w/o ABS
FJR 1300	2001-05	YA 342	S46PR1C1S	25	325	62	01092-34	With and w/o ABS
FJR 1300	2006-12	YA 036	S46HR1C1	16	328	64	01092-49	
FJR 1300	2006-12	YA 053	S46DR1	9	326,5	62,5	01092-49	
FJR 1300	2006-12	YA 707	S46HR1C1S	23	326,5	62,5	01092-49	
FZ 1	2006-13	YA 009	S46DR1	9	320	66	01095-44	With and w/o ABS
FZ 1	2006-13	YA 041	S46HR1C1S	23	320	67,5	01095-44	With and w/o ABS
FZ 8	2010-13	YA 009	S46DR1	9	320	66	01095-44	With and w/o ABS
FZ 8	2010-13	YA 041	S46HR1C1S	23	320	67,5	01095-44	With and w/o ABS
FZ6	2004-07	YA 403	S46ER1	9	305	58	01092-54	
FZ6	2004-07	YA 543	S46HR1C1L	17	305 +11,5/-0,5	58,5	01092-54	
FZ6 S2	2007	YA 723	S46HR1C1	16	305	58	01092-54	
FZ6 S2	2007-09	YA 403	S46ER1	9	305	58	01092-54	
FZS 1000 Fazer	2001-05	YA 050	S46PR1C1S	23	306	68	01091-26	
FZS 1000 Fazer	2001-05	YA 313	S46ER1	9	305,5	65,5	01091-26	
FZS 600 Fazer	1998-03	YA 314	S46DR1	9	305	58	01093-64	
MT 01	2005-11	YA 501	S46PR1C1L	20	311	56	01092-64	
MT 07	2014-15	YA 419	S46DR1	9	312	61,5	01092-41	
MT 09	2014-15	YA 335	S46DR1	9	329	65	01092-31	
R25/R3	2014-15	YA 467	S46HR1C1L	16	277	46	01104-69	
RD 350	1983-88	YA 415	S46ER1	9	293	48	01093-34	
SR 500	All	YA 148	S36P	13	321	82	00480-02	
SR 500	All	YA 952E	S36E	9	320	82	00480-02	
TDM 900	2002-13	YA 506	S46DR1	9	325	68	01095-49	
V-Max	1985-05	YA 137	S36PR1C1LB	30	324 +10/-0	87	00380-05	
V-Max	1985-05	YA 426	S36PR1C1L	30	324 +10/-0	87	00380-05 (Y)	
V-Max	1985-05	YA 427	S36PR1C1L	30	324 +10/-0	87	00360-05 (B)	
XJ 6	2009-13	YA 907	S46DR1	9	281	51,5	01093-74	With and w/o ABS
XJ 600 Diversion	1991-03	YA 055	S46DR1	9	274	51	01093-79	
XJ 900 S Diversion	1995-05	YA 057	S46DR1	9	300,5	54	01093-59	
XJR 1200	1995-98	YA 139	S36PR1C1LB	30	324 +10/-0	91	00380-06	
XJR 1200	1995-98	YA 156	S36P	13	326	94	00480-23	
XJR 1200	1995-98	YA 413	S36PR1C1L	30	325 +10/-0	92	00360-06 (B)	
XJR 1200	1995-98	YA 417	S36PR1C1L	30	325 +10/-0	92	00380-06 (Y)	
XJR 1300	1999-05	YA 139	S36PR1C1LB	30	324 +10/-0	91	00380-06	
XJR 1300	1999-05	YA 156	S36P	13	326	94	00480-23	
XJR 1300	1999-05	YA 413	S36PR1C1L	30	325 +10/-0	92	00360-06 (B)	
XJR 1300	1999-05	YA 417	S36PR1C1L	30	325 +10/-0	92	00380-06 (Y)	
XJR 400	1991-00	YA 145	S36P	13	320,5	83	00480-02	
XT 1200 Z Ténéré	2010-14	YA 013	S46HR1C1S	23	352,5	73,5	01099-49	
XT 660 R	2004-12	YA 418	S46DR1	9	341	68,5	01096-54	
XT 660 X	2004-12	YA 418	S46DR1	9	341	68,5	01096-54	
XT 660 Z Ténéré	2008-12	YA 817	S46PR1C1	16	345	94	01099-24	w/o ABS
YZF R1	2004-06	YA 343	S46PR1C2LS	28	300 +6/-0	64,5	01093-31	
YZF R1	2007-08	YA 932	T36PR1C1LB	29	302 +4/-2	65	21040-31	MKII
YZF R1	2009-14	YA 340	T36PR1C1LS	30	297 +4/-2	60	21040-29	TTX GP
YZF R1	2009-14	YA 362	T36PR1C1LS	30	297 +4/-2	60	21040-29	TTX GP
YZF R1	2009-14	YA 359	T36PR1C1L	23	297 +4/-2	60	21040-29	TTX RT
YZF R1	2015	YA 416	T36PR1C1L	28	315 +6/-0	60	21041-29	TTX GP
YZF R1M	2015	YA 416	T36PR1C1L	28	315 +6/-0	60	21041-29	TTX GP Race use only
YZF R6	2006-15	YA 358	T36PR1C1L	23	293 +5/-1	60	21041-29	TTX RT
YZF R6	2006-15	YA 361	T36PR1C1LB	30	293 +5/-1	60	21041-29	TTX GP

B = Black spring Y = Yellow spring C = Chrome spring



Accessories  
MX & Enduro  
Mechatronics  
HD & Custom  
Road & Track Front  
Street Performance Line  
Scooter Performance Line  
Road & Track Rear



# SCOOTER

FRONT & REAR PRODUCTS

# 2015



# SCOOTER PERFORMANCE LINE

## SHOCK ABSORBERS

Model	Year	Part No	Type Code	Sales Code	P/C	Length	Stroke	Spring	Notes
<b>HONDA</b>									
Click		YA 928	S36PC1	10910	9	297	78	00379-01	
Forza		HO 430	S36PR1	10910	11	400	115	60480-01	
PCX 150	2013-14	HO 427	S36PC1	10911	11	313	88	60281-19	
PS150i		HO 947	S36PC1	10910	21	293	88	00280-14	For rear drum brake model only
MSX 125		HO 324	S36PC1	10911	6	244	40	60281-07/80N/mm	Optional spring 60281-08/100N/mm
<b>YAMAHA</b>									
Fino		YA 928	S36PC1	10910	9	297	78	00379-01	
Lagenda		YA 917	S36PR1C1L	10910	30	280+10/-0	57	00281-61	
Mio		YA 928	S36PC1	10910	9	297	78	00379-01	

## FRONT END PRODUCTS

Model	Year	Part No	Type Code	Sales Code	P/C	Spring	Notes
<b>HONDA</b>							
MSX 125	2011-14	FDK 101	Damping kit	10922	1	68000-04/5,5N/mm	
Mounting tool FDK 101		60000-01		60500			
Optional spring FDK 101		68500-05		10940			6 N/mm

## FRONT END SPRINGS

Model	Part No	P/C	Sales Code	Length	Rate N/mm	Notes
<b>YAMAHA</b>						
TI35 LC4V	08791-60	300	10940	298	6	od 19 mm
<b>UNIVERSAL</b>						
	08501-46	300	10940	274	4,6	od 19,2 mm
	08502-46	300	10940	316	4,6	od 18,4 mm





Our popular and cost effective STX46 shock absorber is the perfect upgrade for naked sports bikes as well as dual sports bikes. We call it the Street Performance Line.



Model	Year	Part No	Type Code	P/C	Length	Stroke	Spring	
<b>BMW</b>								
F 650 GS (2 cyl)	2008-12	BM 058	S46DR1	9	413,5	56,5	01092-69	
F 800 GS	2008-14	BM 043	S46DR1	9	428,5	68,5	00698-69	
F 800 R	2008-14	BM 059	S46DR1	9	350	53	01092-89	
F 800 S	2007-10	BM 060	S46DR1	9	344,5	53,5	01092-89	
F 800 ST	2007-12	BM 060	S46DR1	9	344,5	53,5	01092-89	
R 100 GS	1987-94	BM 051	S46DR1	9	495	80	00698-24	Rear
R 100 PD	1987-94	BM 051	S46DR1	9	495	80	00698-24	Rear
R 100 R	1992-95	BM 052	S46DR1	9	474	74	01096-24	Rear
R 100 RS	1985-93	BM 053	S46DR1	9	409	72	01096-21	Rear
R 100 RT	1985-93	BM 053	S46DR1	9	409	72	01096-21	Rear
R 1100 GS	1994-00	BM 054	S46DR1	9	383	63	01095-64	Rear
R 1100 RS	1993-01	BM 334	S46DR1	9	358	57	01092-64	Rear
R 1150 GS	2000-03	BM 045	S46DR1	9	383	63	01095-54	Rear
R 1150 R	2001-06	BM 061	S46DR1	9	366	56	01092-79	Rear
R 1150 RS	2002-04	BM 062	S46DR1	9	366	56	01092-69	Rear
R 1200 GS	2004-12	BM 044	S46DR1	9	403	78,5	00698-54	Rear
R 1200 GS	2004-12	BM 046	S46DR1	9	395	70,5	00698-54	Rear short
R 1200 GS	2004-12	BM 437	S46ER1	9	337	94	01096-10	Front
R 1200 GS	2004-12	BM 509	S46ER1	9	325	82	01096-10	Front short
R 1200 GS Adventure	2006-12	BM 047	S46DR1	9	409,5	85,5	01103-59	Rear
R 1200 GS Adventure	2006-12	BM 607	S46ER1	9	347	95	01096-12	Front
R 80 GS	1988-94	BM 051	S46DR1	9	495	80	00698-24	Rear
R 80 R	1992-95	BM 052	S46DR1	9	474	74	01096-24	Rear
R 80 RS	1985-93	BM 053	S46DR1	9	409	72	01096-21	Rear
R 80 RT	1985-93	BM 053	S46DR1	9	409	72	01096-21	Rear
R 850 GS	1994-00	BM 054	S46DR1	9	383	63	01095-64	Rear
R 850 R	2003-06	BM 061	S46DR1	9	366	56	01092-79	Rear
<b>DUCATI</b>								
Monster 1000	2003-05	DU 321	S46DR1	9	305	66	01091-34	
Monster 1100	2009-13	DU 737	S46DR1	9	294,5	58,5	01092-41	
Monster 600	1994-01	DU 044	S46DR1	9	330	65	01091-31	
Monster 620	2002-05	DU 321	S46DR1	9	305	66	01091-34	
Monster 696	2008-09	DU 737	S46DR1	9	294,5	58,5	01092-41	
Monster 750	2002	DU 321	S46DR1	9	305	66	01091-34	
Monster 750	1994-01	DU 044	S46DR1	9	330	65	01091-31	
Monster 796	2011-12	DU 737	S46DR1	9	294,5	58,5	01092-41	
Monster 800	2003-05	DU 321	S46DR1	9	305	66	01091-34	
Monster 900	2002	DU 321	S46DR1	9	305	66	01091-34	
Monster 900	1994-01	DU 044	S46DR1	9	330	65	01091-31	
Monster S2R 1000	2005	DU 321	S46DR1	9	305	66	01091-34	
Monster S2R 800	2005	DU 321	S46DR1	9	305	66	01091-34	
Monster S4	2001-05	DU 321	S46DR1	9	305	66	01091-34	
<b>HONDA</b>								
CB 1000 R	2008-14	HO 009	S46DR1	9	310	47	01095-64	
CB500F	2013-14	HO 320	S46DR1	6	150	54	61093-39	
CB 600 F Hornet	1998-04	HO 321	S46DR1	9	306	47	01093-64	
CB 600 F Hornet	2005-06	HO 155	S46DR1	9	306	47	01093-64	
CB 650F	2013-	HO 428	S46DR1	9	331	49	60016-69	
CB 900F Hornet	2002-06	HO 322	S46DR1	9	283	50,5	01093-74	
CBF 1000	2006-09	HO 044	S46DR1	9	293,5	51,5	01093-69	
CBR 500R	2013-14	HO 320	S46DR1	6	307	54	61093-39	
CBR 650R	2013-	HO 428	S46DR1	9	331	49	60016-69	
NC 700 X	2012-13	HO 070	S46DR1	9	312	56,5	01095-54	



Model	Year	Part No	Type Code	P/C	Length	Stroke	Spring	
VFR 800 FI	2002-09	HO 043	S46DR1	9	317,5	53,5	01092-69	
XL 1000 V Varadero	1999-02	HO 046	S46DR1	9	338	65	01095-54	
XL 1000 V Varadero	2003-09	HO 045	S46DR1	9	334	55	01095-69	
XL 600V	1988-90	HO 836	S46ER1	9	355	83	01096-44	
<b>KAWASAKI</b>								
ER-6	2006-08	KA 602	S46DR1	9	290,5	56,5	01093-69	
ER-6 N/F	2009-14	KA 037	S46DR1	9	282	49,5	01093-74	Low version
ER-6 N/F	2009-14	KA 906	S46DR1	9	290	51,5	01093-69	With and w/o ABS
Versys	2006-13	KA 907	S46DR1	9	301,5	51,5	01093-69	With and w/o ABS
Z 1000	2003-06	KA 155	S46DR1	9	338	60	01095-34	
Z 1000	2010-13	KA 043	S46DR1	9	356,5	61,5	01092-26	
Z 750	2007-08	KA 009	S46DR1	9	332	63	01096-31	
Z 750	2004-06	KA 044	S46DR1	9	328	63	01091-31	
Z 750 S	2005	KA 044	S46DR1	9	328	63	01091-31	
ZZ-R 1400	2006-14	KA 046	S46DR1	9	330	65	01091-31	
<b>KTM</b>								
125/200 Duke	2013	KT 301	S46DR1	9	300	63	01091-34	
<b>SUZUKI</b>								
DL 1000 V-Strom	2002-08	SU 508	S46DR1	9	345	75,5	01096-34	
DL 650 V-Strom	2004-14	SU 043	S46DR1	9	340,5	71,5	01096-31	
GSF 1200 Bandit	2001-05	SU 322	S46DR1	9	320	56	01095-44	
GSF 1250 Bandit	2007-14	SU 045	S46DR1	9	320	64	01092-49	With and w/o ABS
GSF 600 Bandit	2000-04	SU 321	S46DR1	9	319	55	01091-39	
GSR 600	2006-09	SU 046	S46DR1	9	337	68	01091-29	
GSR 750	2011-14	SU 121	S46DR1	9	327,5	68,5	01092-34	
SFV 650 Gladius	2009-14	SU 905	S46DR1	9	317	65,5	01091-29	
SV 650	2003-07	SU 323	S46DR1	9	330	70	01096-21	w/o ABS
<b>TRIUMPH</b>								
Speed Triple 1050	2008-10	TR 045	S46DR1	9	370,5	60,5	01095-54	
Street Triple 675	2008-12	TR 043	S46DR1	9	290	56	01093-44	
Street Triple R 675	2009	TR 043	S46DR1	9	290	56	01093-44	
Tiger 1050	2007-12	TR 044	S46DR1	9	350	62,5	01095-44	
<b>YAMAHA</b>								
FJR 1300	2001-05	YA 056	S46DR1	9	325	61	01092-34	With and w/o ABS
FJR 1300	2006-12	YA 053	S46DR1	9	326,5	62,5	01092-49	
FZ 1	2006-13	YA 009	S46DR1	9	320	66	01095-44	With and w/o ABS
FZ 8	2010-13	YA 009	S46DR1	9	320	66	01095-44	With and w/o ABS
FZ6	2004-07	YA 403	S46ER1	9	305	58	01092-54	
FZ6 S2	2007-09	YA 403	S46ER1	9	305	58	01092-54	
FZS 1000 Fazer	2001-05	YA 313	S46ER1	9	305,5	65,5	01091-26	
FZS 600 Fazer	1998-03	YA 314	S46DR1	9	305	58	01093-64	
MT 03	2006	YA 629	S46DR1	9	364	55,5	01093-44	
MT 07	2014-15	YA 419	S46DR1	9	312	61,5	01092-41	
MT 09	2014-15	YA335	S46DR1	9	329	65	01092-31	
RD 350	1983-88	YA 415	S46ER1	9	293	48	01093-34	
TDM 900	2002-13	YA 506	S46DR1	9	325	68	01095-49	
XJ 6	2009-13	YA 907	S46DR1	9	281	51,5	01093-74	With and w/o ABS
XJ 600 Diversion	1991-03	YA 055	S46DR1	9	274	51	01093-79	
XJ 900 S Diversion	1995-05	YA 057	S46DR1	9	300,5	54	01093-59	
XT 660 R	2004-12	YA 418	S46DR1	9	341	68,5	01096-54	
XT 660 X	2004-12	YA 418	S46DR1	9	341	68,5	01096-54	





## FGR300

The improved FGR300 is the very essence of front fork technology. Fully packed with technical solutions and experiences from MotoGP and World Superbike, improvements include a more robust design and increased adjustment possibilities.

- Pressurised TTX25 Cartridge technology
- New stronger outer tube top
- Shorter reservoir tubes
- Improved adjustment features
- Fully engaged top out spring as an option
- Different settings available from Öhlins setting bank



## FGRT200-SERIES

The Road & Track front fork with loads of performance and fantastic comfort. A winner on race tracks as well as a fantastic upgrade to improve the ride on your favourite roads. Features the Öhlins 30mm cartridge kit inside, compression and rebound adjustments easily done with compression adjustment in one leg and rebound adjustment in the other leg.

- Öhlins NIX 30mm Cartridge Kit inside
- Compression damping in one leg, rebound in the other
- Weight and stress optimized fork bottom design
- All adjustments at the top of the fork
- Reduced weight
- Proven in various racing applications
- Available for all major Hypersport models
- Different settings available from Öhlins setting bank



### TTX25 PRESSURIZED CARTRIDGE KIT



- Pressurized system for highest performance
- External rebound, compression and spring pre-load adjustment
- Setting library available for individual preferences
- 3 sets of springs are included in the kit, more spring rates available as spare parts

### NIX30 CARTRIDGE KIT



- External rebound, compression and spring pre-load adjusters
- Easy to change settings for individual preferences, based on our existing setting bank
- Wide range of spring rates available in the 08790-series
- Easy installation and service
- Available to all hypersport bikes, and also to many adventure bikes (see FKA kits)

### STEERING DAMPER



- Unique design
- Fluid under pressure to avoid free play
- Adjustable in 16 clicks
- Six lengths/strokes
- Can be mounted outside the fork leg or across the frame behind the triple clamp
- Kits complete with mounting brackets available for certain bike models
- Universal parts for race bikes available



# FRONT END PRODUCTS

## ROAD&TRACK

Model	Year	Part No	Type Code	P/C	Length	Stroke	Spring	Notes
<b>APRILIA</b>								
RSV 4 Factory Öhlins front fork	2010-15	FGK 215	NIX 30mm Cart. Kit	107	730	120	*	08790-xx series spring
RSV 4 Factory Öhlins front fork	2010-15	FGR 165	TTX25 press. Cartr kit.	113	730	120	x	Springs -90,-95,-10 included in kit
RSV 4 R Sachs front fork	2010-14	FGK 223	NIX 30mm Cart. Kit	107	720	120	*	Sachs fork 08790-xx series spring
<b>BMW</b>								
HP 4	2013-14	FGRT 202	FG R/T NIX	114	740	120	04744-10	Race use only
HP 4	2013-14	FGRT 212	FG R/T NIX	114	740	120	04744-10	Black Outer tube Race use only
HP 4	2013-14	FGK 212	NIX 30mm Cart. Kit	107	741	120	*	08790-xx series spring Race use only
HP 4	2013-14	FGR 162	TTX25 press. Cartr kit.	113	741	120	x	Springs -95,-10,-05 included in kit Race use only
R nineT	2014-15	FGK 231	NIX 30mm Cart. Kit	107	741	120	*	08790-xx series spring
R nineT	2014-15	FGRT 216	FG R/T NIX	114	740	120	04744-90	Black outer tube
R nineT	2014-15	FGRT 218	FG R/T NIX	114	740	120	04744-90	Gold outer tube
S 1000 R	2014	FGK 233	NIX 30mm Cart. Kit	107	741	120	*	08790-xx series spring
S 1000 R	2014	FGRT 217	FG R/T NIX	114	740	120	04744-90	
S 1000 RR	2008-15	FGRT 202	FG R/T NIX	114	740	120	04744-10	
S 1000 RR	2008-15	FGRT 212	FG R/T NIX	114	740	120	04744-10	Black Outer tube
S 1000 RR	2008-15	FGK 212	NIX 30mm Cart. Kit	107	741	120	*	08790-xx series spring
S 1000 RR	2008-15	FGR 162	TTX25 press. Cartr kit.	113	741	120	x	Springs -95,-10,-05 included in kit
<b>DUCATI</b>								
848	2008-13	FGK 210	NIX 30mm Cart. Kit	107	717	120	*	08790-xx series spring
848	2008-13	FGR 160	TTX25 press. Cartr kit.	113	717	120	x	Springs -90,-95,-10 included in kit
848	2008-13	FGRT 210	FG R/T NIX	114	715	120	04744-10	Replaces FGRT 819
848	2008-13	FGRT 213	FG R/T NIX	114	715	120	04744-10	Black Outer tubes
899 Panigale	2014-15	FGK 229	NIX 30mm Cart. Kit	107	738	120	*	Showa fork, 08790-xx series springs
899 Panigale	2014-15	FGR 179	TTX25 press. Cartr kit.	113	738	120	x	Showa fork, Springs -95,-10,-05 included in kit
899 Panigale	2014-15	FGRT 214	FG R/T NIX	114	740	120	04744-10	Black outer tubes.
1098	2007-08	FGK 210	NIX 30mm Cart. Kit	107	717	120	*	08790-xx series spring
1098	2007-08	FGR 160	TTX25 press. Cartr kit.	113	717	120	x	Springs -90,-95,-10 included in kit
1098	2006-08	FGRT 210	FG R/T NIX	114	715	120	04744-10	Replaces FGRT 819
1098	2006-08	FGRT 213	FG R/T NIX	114	715	120	04744-10	Black Outer tubes
1198	2009-11	FGK 210	NIX 30mm Cart. Kit	107	717	120	*	08790-xx series spring
1198	2009-11	FGR 160	TTX25 press. Cartr kit.	113	717	120	x	Springs -90,-95,-10 included in kit
1198	2009-11	FGRT 210	FG R/T NIX	114	715	120	04744-10	Replaces FGRT 819
1198	2009-11	FGRT 213	FG R/T NIX	114	715	120	04744-10	Black outer tubes
1098 R / 1098 S	2006-08	FGRT 211	FG R/T NIX	114	715	120	04744-10	Replaces FGRT 815
1098 R / 1098 S	2007-08	FGR 163	TTX25 press. Cartr kit.	113	717	120	x	Springs -90,-95,-10 included in kit
1198 R	2009-10	FGR 163	TTX25 press. Cartr kit.	113	717	120	x	Springs -90,-95,-10 included in kit
1198 R / 1198 S	2009-10	FGRT 211	FG R/T NIX	114	715	120	04744-10	Replaces FGRT 815
1198 S	2009-10	FGR 163	TTX25 press. Cartr kit.	113	717	120	x	Springs -90,-95,-10 included in kit
1198 SP	2011	FGR 163	TTX25 press. Cartr kit.	113	717	120	x	Springs -90,-95,-10 included in kit
1198 SP	2011	FGRT 211	FG R/T NIX	114	715	120	04744-10	Replaces FGRT 815
1199 Panigale	2012-14	FGRT 203	FG R/T NIX	114	740	120	04744-10	Fits base version of Panigale
1199 Panigale (Marzocchi)	2012-14	FGK 224	NIX 30mm Cart. Kit	107	741	120	*	For Marzocchi front fork, 08790-xx series springs
1199 Panigale (Marzocchi)	2012-14	FGR 174	TTX25 press. Cartr kit.	113	741	120	x	Springs -95,-10,-05 included in kit
1199 Panigale S (Öhlins)	2012-14	FGK 219	NIX 30mm Cart. Kit	107	738	120	*	S-model only 08790-xx series spring
1199 Panigale S (Öhlins)	2012-14	FGR 169	TTX25 press. Cartr kit.	113	738	120	x	Springs -95,-10,-05 included in kit
Diavel	2011-14	FGRT 301	FG R/T NIX	116	765	120	04744-95	48mm Innertube
<b>HONDA</b>								
CBR 1000 RR	2008-11	FGK 203	NIX 30mm Cart. Kit	107	717	122	*	With and w/o ABS, 08790-xx series spring
CBR 1000 RR	2008-11	FGR 153	TTX25 press. Cartr kit.	113	717	122	x	Springs -90,-95,-10 included in kit

## ROAD&TRACK

Model	Year	Part No	Type Code	P/C	Length	Stroke	Spring	Notes
CBR 1000 RR	2012-14	FGRT 204	FG R/T NIX	114	710	120	04744-10	With and w/o ABS
CBR 1000 RR	2012-14	FGK 222	NIX 30mm Cart. Kit	107	710	120	*	With and w/o ABS, 08790-xx series spring
CBR 1000 RR	2012-14	FGR 172	TTX25 press. Cartr kit.	113	721	125	x	Springs -90,-95,-10 included in kit
CBR 1000 RR SP	2014	FGR 178	TTX25 press. Cartr kit.	113	710	120	x	For Öhlins fork FL 910 Springs -95,-10,-05 included
CBR 600 RR	2007-12	FGK 204	NIX 30mm Cart. Kit	107	720	130	*	With and w/o ABS, 08790-xx series spring
CBR 600 RR	2013-14	FGK 226	NIX 30mm Cart. Kit	107	717	120	*	Showa, 08790-xx series springs
CBR 600 RR	2007-12	FGR 154	TTX25 press. Cartr kit.	113	720	130	x	Springs -90,-95,-10 included in kit
CBR 600 RR	2013-14	FGR 176	TTX25 press. Cartr kit.	113	717	120	x	Showa, Springs -90,-95,-10 included in kit.
<b>KAWASAKI</b>								
Z 1000	2014	FGK 232	NIX 30mm Cart. Kit	107	727	120	*	08790-xx series spring
ZX 10 R	2008-10	FGK 205	NIX 30mm Cart. Kit	107	762,5	120	*	08790-xx series spring
ZX 10 R	2011-14	FGK 216	NIX 30mm Cart. Kit	107	739	120	*	08790-xx series spring
ZX 10 R	2011-14	FGR 166	TTX25 press. Cartr kit.	113	739	120	x	Springs -95,-10,-05 included in kit
ZX 10 R	2011-14	FGRT 201	FG R/T NIX	114	740	120	04744-10	
ZX 10 R	2008-10	FGK 142	Cartridge kit	111	762	120	04744-95	
ZX 6 R	2009-14	FGK 206	NIX 30mm Cart. Kit	107	746,5	120	*	08790-xx series spring
ZX 6 R (636)	2013-14	FGK 227	NIX 30mm Cart. Kit	107	746,5	120	*	08790-xx series spring
ZX 6 R (636)	2013-14	FGR 177	TTX25 press. Cartr kit.	113	746,5	120	x	Springs -90,-95,-10 included in kit
ZZ-R 1400	2006-13	FGRT 207	FG R/T NIX	114	755	120	04744-95	
<b>SUZUKI</b>								
GSX 1300 R Hayabusa	2008-12	FGRT 208	FG R/T NIX	114	730	120	04744-10	
GSX-R 1000	2009-11	FGK 207	NIX 30mm Cart. Kit	107	735	125	*	08790-xx series spring
GSX-R 1000	2009-11	FGR 157	TTX25 press. Cartr kit.	113	735	125	x	Springs -95,-10,-05 included in kit
GSX-R 1000	2012-14	FGRT 205	FG R/T NIX	114	725	120	04744-10	
GSX-R 1000	2012-14	FGK 221	NIX 30mm Cart. Kit	107	723	120	*	08790-xx series spring
GSX-R 1000	2012-14	FGR 171	TTX25 press. Cartr kit.	113	723	120	x	Springs -95,-10,-05 included in kit
GSX-R 600	2011-14	FGR 167	TTX25 press. Cartr kit.	113	722	120	x	Springs -90,-95,-10 included in kit
GSX-R 600	2006-10	FGK 208	NIX 30mm Cart. Kit	107	737	120	*	08790-xx series spring
GSX-R 600	2011-14	FGK 217	NIX 30mm Cart. Kit	107	722	120	*	08790-xx series spring
GSX-R 750	2011-14	FGK 217	NIX 30mm Cart. Kit	107	722	120	*	08790-xx series spring
GSX-R 750	2011-14	FGR 167	TTX25 press. Cartr kit.	113	722	120	x	Springs -90,-95,-10 included in kit
GSX-R 750	2006-07	FGK 208	NIX 30mm Cart. Kit	107	737	120	*	08790-xx series spring
<b>TRIUMPH</b>								
Daytona 675	2009-12	FGK 209	NIX 30mm Cart. Kit	107	726	110	*	08790-xx series spring
Daytona 675 R For Öhlins fork (FL 906)	2013-14	FGR 175	TTX25 press. Cartr kit.	113	743	120	X	Springs -90,-95,-10 included in kit
<b>YAMAHA</b>								
FZ 8	2011-13	FGK 218	NIX 30mm Cart. Kit	107	745	130	*	08790-xx series spring
MT-09	2014	FGK 230	NIX 30mm Cart. Kit	107	804	137	*	08423-90 spring
YZF R1	2009-14	FGRT 206	FG R/T NIX	114	740	130	04744-05	
YZF R1	2009-14	FGK 201	NIX 30mm Cart. Kit	107	731	120	*	08790-xx series spring
YZF R1 M	2015	FGK 234	NIX 30mm Cart. Kit	107	749	120	*	For FL 912 Race use only, 08790-xx series springs
YZF R1	2009-14	FGR 151	TTX25 press. Cartr kit.	113	731	120	x	Springs -95,-10,-05 included in kit
YZF R1 M	2015	FGR 184	TTX25 press. Cartr kit.	113	749	120	x	For FL 912 Race use only, Springs -95,-10,-05 included
YZF R6	2008-14	FGK 202	NIX 30mm Cart. Kit	107	744	120	*	08790-xx series spring
YZF R6	2008-14	FGR 152	TTX25 press. Cartr kit.	113	744	120	x	Springs -90,-95,-10 included in kit
<b>UNIVERSAL</b>								
Superbike		FGR 300	FG 43 RR	125	750	130	04744-10	Springs -95,-05,-11, included in kit
Universal/Gold USD		FG 324	FG R/T GOLD	113	800	120	04744-85	w/o brake caliper/fender mounts
Universal/Black USD		FG 424	FG R/T BLACK	113	800	120	04744-85	w/o brake caliper/fender mounts
Universal/Black RWU		FG 433	FG RWU BLACK	112	800	130	08701-95	w/o brake caliper/fender mounts
Universal/Gold RWU		FG 434	FG RWU GOLD	112	800	130	08701-95	w/o brake caliper/fender mounts

\*Delivered without spring, must be ordered separately. X = Springs included in kit.



# FORK KIT ADVENTURE - FKA

ROAD&TRACK

Öhlins offer front end upgrades to Adventure bikes. Based on the successful road racing NIX kits, the Öhlins cartridge kits have now been made for adventure bikes.



Model	Year	Part No	Type Code	P/C	Sales Code	Length	Stroke	Spring	Notes
<b>BMW</b>									
F 800 GS (Marzocchi)	2008-12	FKA 101	FG-kit NIX	107	10321	910	230	*	08767-series springs
F 800 GS (WP)	2013-14	FKA 105	FG-kit NIX	107	10321	920	235	*	08418-series springs
F 800 GS Adventure (WP)	2013-14	FKA 105	FG-kit NIX	107	10321	920	235	*	08418-series springs
<b>DUCATI</b>									
Multistrada 1200 (Marzocchi)	2009-12	FKA 104	FG-kit NIX	107	10321	864	170	*	08410-series springs
<b>TRIUMPH</b>									
Tiger 800 (Showa)	2011-14	FKA 102	FG-kit NIX	107	10321	813	170	*	08415-series springs
Tiger 800 XC (Showa)	2011-14	FKA 103	FG-kit NIX	107	10321	851	215	*	08416-series springs
<b>YAMAHA</b>									
XT 1200 Z (KYB)	2010-14	FKA 106	FG-kit NIX	107	10321	872	190	*	Not for XT1200ZE model. 08424-series springs

\*Delivered without spring, must be ordered separately.

# FORK PISTON KIT - FPK

The Fork Piston Kit is a big improvement to the front fork feel and performance. Each kit contains two complete sets of pre-assembled compression and rebound pistons, including shims and one-way valves. The FPK is easy to install and fits bolt-on without modifications to the original front fork. For bikes not in the list, our global service centers can tune the OEM forks by using any of the Universal Front Fork piston kits.



Model	Year	Part No	Type Code	P/C	Notes
<b>APRILIA</b>					
RSV 4 R Showa front fork	2010-11	FPK 111	Fork piston kit	See parts price list	Showa front fork
<b>DUCATI</b>					
848	2007-12	FPK 103	Fork piston kit	See parts price list	
1098	2007-08	FPK 103	Fork piston kit	See parts price list	
1198	2009-11	FPK 103	Fork piston kit	See parts price list	
FG 511 Performance kit		03200-27	Fork piston kit	See parts price list	
<b>HONDA</b>					
CBR 1000 RR	2008-11	FPK 101	Fork piston kit	See parts price list	With and wo ABS
CBR 600 RR	2007-12	FPK 106	Fork piston kit	See parts price list	With and wo ABS
<b>KAWASAKI</b>					
ZX 10 R	2008-10	FPK 105	Fork piston kit	See parts price list	
<b>SUZUKI</b>					
GSX-R 1000	2005-08	FPK 104	Fork piston kit	See parts price list	
GSX-R 600	2008-10	FPK 102	Fork piston kit	See parts price list	
GSX-R 750	2006-07	FPK 102	Fork piston kit	See parts price list	
<b>TRIUMPH</b>					
Daytona 675	2008	FPK 109	Fork piston kit	See parts price list	
<b>YAMAHA</b>					
YZF R1	2009-13	FPK 108	Fork piston kit	See parts price list	
YZF R6	2006-13	FPK 107	Fork piston kit	See parts price list	
<b>UNIVERSAL</b>					
Front Fork Piston Kit Ø20mm		03200-01	Fork piston kit	See parts price list	Universal type
Front Fork Piston Kit Ø25mm		03200-25	Fork piston kit	See parts price list	Universal type

For best performance we recommend using the FPK together with Öhlins front fork springs and front fork fluid (part no. 01309-01)

ROAD&TRACK

# FRONT SPRINGS

Model	Year	Part No	P/C	Length	Rate N/mm	Rec. Öhlins Oil	Oil level (mm)	Notes
<b>BMW</b>								
F 650 CS	2002-04	08682-70	300	365	7.0			
F 700 GS	2013-14	08414-70	300	550	7.0	01316	170	**
F 800 GS	2008-12	08767-50	300	480	5.0	01309	60	
F 800 GS	2008-12	08767-55	300	480	5.5	01309	60	
F 800 GS	2008-12	08767-60	300	480	6.0	01309	60	**
F 800 GS	2013-14	08417-55	300	495	5.5	01309	70	Std version/**
F 800 R	2009-14	08688-90	300	448	9.0	01313	130	
F 800 S	2007-10	08751-90	300	440	9.0	01313	140	
F 800 ST	2007-10	08751-90	300	440	9.0	01313	140	
K 75	1990-91	08806-01	300		8.0	01316	150	w/o ABS
R nine T	2014	08426-90	300	250	9.0			
S 1000 RR	2012-14	08407-95	300	215	9.5	01309	90	**
S 1000 RR	2012-14	08407-10	300	215	10.0	01309	90	*/**
S 1000 RR	2012-14	08407-05	300	215	10.5	01309	90	**
S 1000 RR	2010-11	08792-95	300	209	9.5	01309	90	*/**
S 1000 RR	2010-11	08792-10	300	209	10.0	01309	90	**
S 1000 RR	2010-11	08792-05	300	209	10.5	01309	90	**
<b>DUCATI</b>								
748	1994-99	08627-90	300	287	9.0	01309	110	
748	1994-99	08627-90	300	287	9.0	01309	110	Privateer racing
848	2008-13	08761-95	300	310	9.5	01309	180	*/**
848	2008-13	08761-10	300	310	10.0	01309	180	**
848	2008-13	08761-05	300	310	10.5	01309	180	**
916	1994-98	08627-90	300	287	9.0	01309	110	
916	1994-99	08627-90	300	287	9.0	01309	110	Privateer racing
996	1999	08627-90	300	287	9.0	01309	110	
996	1999	08627-90	300	287	9.0	01309	110	Privateer racing
1098	2008	08761-95	300	310	9.5	01309	180	*/**
1098	2008	08761-10	300	310	10.0	01309	180	**
1098	2008	08761-05	300	310	10.5	01309	180	**
1198	2009-11	08761-95	300	310	9.5	01309	155	*/**
1198	2009-11	08761-10	300	310	10.0	01309	155	**
1198	2009-11	08761-05	300	310	10.5	01309	155	**
1199 Panigale (Marzocchi)	2012-14	08411-95	300	250	9.5	***	***	
1199 Panigale (Marzocchi)	2012-14	08411-05	300	250	10.5	***	***	
748 Biposto	1995-99	08627-90	300	287	9.0	***	***	
916 Biposto	1995-98	08627-90	300	287	9.0	01309	110	
996 Biposto	1999	08627-90	300	287	9.0	01309	110	
Monster S2R 800	2005	08627-90	300	287	9.0	01313	70	Privateer racing
Monster S4	2001-05	08643-90	300	370	9.0	***	***	
Multistrada	2003-05	08700-85	300	345	8.5	***	***	
Multistrada 1200	2010-12	08410-65	300	328	6.5	01309	145	
Multistrada 1200	2010-12	08410-70	300	328	7.0	01309	145	**
ST 2	1997-00	08643-90	300	370	9.0	01309	110	
ST 4	1997-00	08643-90	300	370	9.0	01309	110	
<b>HARLEY-DAVIDSON</b>								
XR 1200	2009	08788-85	300	340	8.5	01309	100	
FLH/FLT		08419-10	300	278	10.0	01309	80	FKC 101
<b>HONDA</b>								
CB 1000 BIG	1993-97	08833-01	300		8.0	***	***	
CB 1000 R	2008-14	08665-90	300	250	9.0	01313	110	*
CB 1000 R	2008-14	08665-95	300	250	9.5	01313	110	
CB 600 F Hornet	2009-12	08724-90	300	267	9.0	01309	80	**
CB 600 F Hornet	2009-12	08724-95	300	267	9.5	01309	80	**

Road & Track Rear, Scooter Performance Line, Street Performance Line, Road & Track Front, HD & Custom, Mechanics, MX & Enduro, Accessories



# FRONT SPRINGS

## ROAD&TRACK

Model	Year	Part No	P/C	Length	Rate N/mm	Rec. Öhlins Oil	Oil level (mm)	Notes
<b>HONDA</b>								
CB 600 F Hornet	2009-12	08724-10	300	267	10.0	01309	80	**
CB 600F Hornet	1998-02	08803-01	300		8.0	01313	130	*
CB 600F Hornet	1998-02	08803-03	300		8.5	01313	130	
CB 600F Hornet	2003-04	08803-04	300		8.5	01316	130	
CB 600F Hornet	2005-06	08717-80	300	280	8.0	01316	90	
CB 600F Hornet	2005-06	08717-85	300	280	8.5	01316	90	
CB 600F Hornet	2007-08	08747-90	300	245	9.0	01309	75	**
CB 900F Hornet	2002-03	08686-85	300	285	8.5	01309	140	
CBF 1000	2006-09	08757-85	300	357	8.5	01313	120	
CBR 1000 RR	2004-07	08704-95	300	220	9.5	01309	120	*
CBR 1000 RR	2004-07	08704-10	300	220	10.0	01309	120	
CBR 1000 RR	2008-11	08672-95	300	235	9.5	01309	93	Wi and w/o ABS for 2009 **
CBR 1000 RR	2008-11	08672-10	300	235	10.0	01309	93	Wi and w/o ABS for 2009 */**
CBR 1000 RR	2012-14	08405-95	300	230	9.5	01309	82	Wi and w/o ABS ***
CBR 1000 RR	2012-14	08405-10	300	230	10.0	01309	82	Wi and w/o ABS */***
CBR 1000 RR	2012-14	08405-05	300	230	10.5	01309	82	Wi and w/o ABS ***
CBR 1000 RR	2012-14	08405-11	300	230	11.0	01309	82	Wi and w/o ABS ***
CBR 1100 XX	1997-06	08633-95	300	237	9.5	01312	150	
CBR 600 F	1997-98	08634-85	300	374	8.5	01309	135	
CBR 600 F	1999-00	08653-90	300	335	9.0	***	***	
CBR 600 F	2001-02	08670-95	300	285	9.5	01309	130	
CBR 600 F	2011-12	08724-90	300	267	9.0	01309	80	**
CBR 600 F	2011-12	08724-95	300	267	9.5	01309	80	**
CBR 600 F	2011-12	08724-10	300	267	10.0	01309	80	**
CBR 600 F Sport	2001-02	08670-95	300	285	9.5	01313	140	
CBR 600 F2	1991-92	08804-01	300		7.5	***	***	
CBR 600 F2	1993-94	08604-80	300	415	8.0	***	***	
CBR 600 RR	2003-04	08694-90	300	259	9.0	01309	110	*
CBR 600 RR	2003-04	08694-95	300	259	9.5	01309	110	
CBR 600 RR	2005-06	08715-90	300	275	9.0	01309	110	*
CBR 600 RR	2005-06	08715-95	300	275	9.5	01309	110	
CBR 600 RR	2005-06	08715-10	300	275	10.0	01309	110	
CBR 600 RR	2007-12	08747-90	300	245	9.0	01309	115	*/**
CBR 600 RR	2007-12	08747-95	300	245	9.5	01309	115	**
CBR 600 RR	2007-12	08747-10	300	245	10.0	01309	115	**
CBR 600 RR	2013-14	08412-95	300	220	9.5	01309	70	***
CBR 600 RR	2013-14	08412-10	300	220	10.0	01309	70	***
CBR 900 RR	1994-99	08635-85	300	250	8.5	01309	120	
CBR 900 RR	1994-99	08635-90	300	250	9.0	01309	120	
CBR 900 RR	2000-01	08664-95	300	230	9.5	01309	120	
CBR 900 RR	2002-03	08665-85	300	250	8.5	01309	110	*
CBR 900 RR	2002-03	08665-90	300	250	9.0	01309	110	
CBR 900 RR	2002-03	08665-95	300	250	9.5	01309	110	
CBR 929	2000-01	08664-95	300	230	9.5	***	***	
CBR 954	2002-03	08665-85	300	250	8.5	***	***	*
CBR 954	2002-03	08665-90	300	250	9.0	***	***	
CBR 954	2002-03	08665-95	300	250	9.5	***	***	
NC 700 X	2012-13	08409-85	300	390	8.5	01316	90	
RC 51	2000-06	08662-10	300	255	10.0	***	***	
VFR 1200 F	2010-14	08795-10	300	233	10.0	***	***	*
VFR 1200 F	2010-14	08795-11	300	233	11.0	***	***	
VFR 750 F	1990-91	08604-80	300	415	8.0	01309	120	

## ROAD&TRACK

Model	Year	Part No	P/C	Length	Rate N/mm	Rec. Öhlins Oil	Oil level (mm)	Notes
VFR 750 F	1994-97	08837-01	300		8.0	01309	120	
VFR 800 FI	1998-01	08644-80	300	380	8.0	01309	145	
VFR 800 FI	2002-05	08687-85	300	335	8.5	01313	110	
VFR 800 X Crossrunner	2011-12	08668-85	300	320	8.5	01309	90	**
VTR 1000 F	1997-06	08805-01	300		8.5	01309	140	
VTR 1000 SP1	2000-01	08662-10	300	255	10.0	01309	120	
VTR 1000 SP2	2002-06	08662-10	300	255	10.0	01309	120	
X 11	2000	08668-90	300	320	9.0	01314	130	
XL 1000 V Varadero	1999-00	08655-70	300	430	7.0	01314	130	
XL 1000 V Varadero	2003-12	08725-80	300	485	8.0	01314	130	ABS
XL 1000 V Varadero	2003-12	08725-85	300	485	8,5	01314	130	ABS
<b>KAWASAKI</b>								
ER-6	2006-08	08705-85	300	280	8.5	01314	130	
ER-6	2009-11	08778-90	300	293	9.0	01309	120	**
ER-6	2012-14	08408-85	300		8,5	***	***	
GPZ 1100	1995-96	08820-01	300		9.0	01316	150	ABS
GPZ 900 R	1984-89	08460-85	300	460	8.5	01314	150	
GPZ 900 R	1990-98	08841-01	300		8.5	01313	130	
GPZ 900 R	1999-00	08669-90	300		9.0	***	***	
Versys	2006-14	08777-90	300	293	9.0	01309	85	**
Versys 1000	2012-14	08651-85	300	364,5	8,5	***	***	
VN 2000	2004-09	08860-01	300		prog. 7-13	01309	200	
VN 900 Classic	2006-09	08858-01	300		prog.4,5-10,5	01309	160	
VN 900 Custom	2007-09	08859-01	300		prog. 5-10	01309	185	
Z 1000	2007-13	08754-95	300	272	9.5	01309	133	**
Z 750	2004-05	08705-90	300	280	9.0	01316	150	
Z 750 R	2011-12	08724-90	300	267	9.0	01309	115	**
Z 750 R	2011-12	08724-95	300	267	9.5	01309	115	**
Z 750 R	2011-12	08724-10	300	267	10.0	01309	115	**
Z 750 S	2005	08718-90	300	320	9.0	***	***	
ZRX 1100	1997-99	08622-80	300	400	8.0	01314	130	
ZRX 1200	2002	08691-90	300	285	9.0	01314	130	
ZX 10 R	2004-05	08702-10	300	250	10.0	01309	110	
ZX 10 R	2008-09	08759-10	300	235	10.0	01309	110	
ZX 10 R	2011-14	08779-95	300	243	9.5	01309	73	***
ZX 10 R	2011-14	08779-10	300	243	10.0	01309	73	***
ZX 10 R	2011-14	08779-05	300	243	10.5	01309	73	***
ZX 10 R	2011-14	08779-11	300	243	11.0	01309	73	***
ZX 12 R	2000-05	08667-95	300	250	9.5	01309	110	
ZX 6 R	2003	08693-90	300	258	9.0	01309	110	
ZX 6 R	2003	08693-10	300	258	10.0	01309	110	
ZX 6 R	2004	08701-80	300	250	8.0	01309	110	*
ZX 6 R	1995-97	08390-85	300	390	8.5	01309	130	
ZX 6 R	2005-06	08714-95	300	250	9.5	01309	95	
ZX 6 R	2005-06	08714-10	300	250	10.0	01309	95	
ZX 6 R	2007-08	08748-90	300	260	9.0	01309	110	*/**
ZX 6 R	2007-08	08748-95	300	260	9.5	01309	110	**
ZX 6 R	2009-14	08773-90	300	235	9.0	01309	80	***
ZX 6 R	2009-14	08773-10	300	235	10.0	01309	80	***
ZX 6 R (636)	2013-14	08413-95	300	255	9.5	01309	85	***
ZX 6 R (636)	2013-14	08413-10	300	255	10.0	01309	85	***
ZX 6 RR	2003	08693-90	300	258	9.0	01309	110	*
ZX 6 RR	2003	08693-10	300	258	10.0	01309	110	
ZX 6 RR	2004	08701-80	300	250	8.0	01309	110	*
ZX 6 RR	2005-06	08713-90	300	299	9.0	01309	110	

Accessories MX & Enduro HD & Custom Road & Track Front Street Performance Line Scooter Performance Line Road & Track Rear



# FRONT SPRINGS

## ROAD&TRACK

Model	Year	Part No	P/C	Length	Rate N/mm	Rec. Öhlins Oil	Oil level (mm)	Notes
<b>KAWASAKI</b>								
ZX 7 R	1996-01	08646-95	300	330	9.5	01309	110	
ZX 9 R	1999	08689-10	300	270	10.0	01309	130	
ZZ-R 1100	1993-99	08606-90	300	294	9.0	01316	150	
ZZ-R 1100	1993-99	08606-10	300	294	10.0	01316	150	
ZZ-R 1400	2008-11	08768-95	300	260	9.5	01309	95	**
ZZ-R 1400	2012-13	08744-95	300	240	9.5	01309	95	**
ZZ-R 1400	2012-13	08744-10	300	240	10.0	01309	95	**
ZZ-R 1400	2012-13	08744-05	300	240	10.5	01309	95	**
ZZ-R 600	1990-92	08603-75	300	415	7.5	01316	100	
ZZ-R 600	1990-92	08603-80	300	415	8.0	01316	100	
ZZ-R 600	1993-94	08619-75	300	285	7.5	01316	100	
ZZ-R 600	1993-94	08619-80	300	285	8.0	01316	100	
ZZ-R 600	1993-94	08619-85	300	285	8.5	01316	100	
<b>KTM</b>								
RC 8	2008-14	08776-95	300	250	9.5	1309	150	**
<b>SUZUKI</b>								
B-King	2007-09	08768-95	300	260	9.5	01309	105	**
C 1500	2005-07	08855-01	300		prog. 5-17	***	200	
C 1800R	2008-09	08861-01	300		prog. 5,5-18	***	200	
C 800	2005-09	08852-01	300		prog. 5-14	***	195	
C 800C	2009	08852-01	300		prog. 5-14	***	195	
DL 1000 V-Strom	2002	08688-90	300	448	9.0	01309	130	
DL 650 V-Strom	2004-14	08771-80	300	445	8.0	01309	145	**
GSF 1200 Bandit	1996-00	08842-01	300		8.5	***	***	
GSF 1200 Bandit	1997-00	08842-01	300		8.5	***	***	ABS
GSF 1200 Bandit	2001-05	08674-90	300	375	9.0	01309	120	
GSF 600 Bandit	1995-99	08619-75	300	285	7.5	01309	120	
GSF 600 Bandit	1995-99	08619-80	300	285	8.0	01309	120	
GSF 600 Bandit	2000-04	08666-70	300	345	7.0	01316	150	
GSF 650 Bandit	2005-06	08752-85	300	380	8.5	***	137	ABS **
GSF 650 Bandit	2005-06	08719-85	300	337	8.5	***	***	w/o ABS
GSF 650 Bandit	2007-08	08752-85	300	380	8.5	***	137	ABS **
GSR 600	2006-09	08729-85	300	335	8.5	01309	120	
GSR 750	2011-14	08402-90	300	290	9.0	***	***	
GSX 1100 R	1989	08815-01	300		10.0	***	***	
GSX 1100 R	1990-92	08606-90	300	294	9.0	01309	110	
GSX 1100 R	1990-92	08606-10	300	294	10.0	01309	110	
GSX 1100 R W	1993-94	08606-90	300	294	9.0	01309	110	
GSX 1100 R W	1993-94	08606-10	300	294	10.0	01309	110	
GSX 1300 R Hayabusa	1999-07	08656-90	300	246	9.0	01309	98	**
GSX 1300 R Hayabusa	1999-07	08656-95	300	246	9.5	01309	98	**
GSX 1300 R Hayabusa	1999-07	08656-10	300	246	10.0	01309	98	**
GSX 1300 R Hayabusa	2008-12	08796-10	300	265	10.0	01309	110	
GSX 600 F	1998-03	08647-80	300	365	8.0	***	***	
GSX 650F	2008-09	08752-85	300	380	8.5	***	***	ABS
GSX 650F	2008-09	08719-85	300	337	8.5	***	***	w/o ABS
GSX 750	1998-99	08648-75	300	395	7.5	***	***	Naked
GSX 750 F	1998-03	08647-80	300	365	8.0	01309	110	
GSX-R 1000	2001-02	08672-95	300	235	9.5	01309	110	
GSX-R 1000	2001-02	08672-10	300	235	10.0	01309	110	
GSX-R 1000	2003-06	08697-95	300	230	9.5	01309	110	
GSX-R 1000	2003-06	08697-10	300	230	10.0	01309	110	
GSX-R 1000	2007-08	08744-95	300	240	9.5	01309	120	*/**
GSX-R 1000	2007-08	08744-10	300	240	10.0	01309	120	**

## ROAD&TRACK

Model	Year	Part No	P/C	Length	Rate N/mm	Rec. Öhlins Oil	Oil level (mm)	Notes
GSX-R 1000	2007-08	08744-05	300	240	10.5	01309	120	**
GSX-R 1000	2009-11	08779-95	300	243	9.5	01309	77	*/***
GSX-R 1000	2009-11	08779-10	300	243	10.0	01309	77	***
GSX-R 1000	2009-11	08779-05	300	243	10.5	01309	77	***
GSX-R 1000	2009-11	08779-11	300	243	11.0	01309	77	***
GSX-R 1000	2012-14	08406-95	300	235	9.5	01309	73	***
GSX-R 1000	2012-14	08406-10	300	235	10.0	01309	73	*/***
GSX-R 1000	2012-14	08406-05	300	235	10.5	01309	73	***
GSX-R 1000	2012-14	08406-11	300	235	11.0	01309	73	***
GSX-R 600	1997-00	08635-85	300	270	8.5	01309	110	
GSX-R 600	1997-00	08635-90	300	270	9.0	01309	110	
GSX-R 600	2001-03	08671-90	300	246	9.0	01309	110	*
GSX-R 600	2004-05	08656-90	300	246	9.0	01309	102	**
GSX-R 600	2004-05	08656-95	300	246	9.5	01309	102	*/**
GSX-R 600	2004-05	08656-10	300	246	10.0	01309	102	**
GSX-R 600	2006-09	08724-90	300	267	9.0	01309	110	*/**
GSX-R 600	2006-09	08724-95	300	267	9.5	01309	110	**
GSX-R 600	2006-09	08724-10	300	267	10.0	01309	110	**
GSX-R 600	2011-14	08773-90	300	235	9.0	01309	75	***
GSX-R 600	2011-14	08773-10	300	235	10.0	01309	75	***
GSX-R 750	2000-03	08665-85	300	250	8.5	01309	110	
GSX-R 750	2000-03	08665-90	300	250	9.0	01309	110	
GSX-R 750	2000-03	08665-95	300	250	9.5	01309	110	
GSX-R 750	2004-05	08656-90	300	246	9.0	01309	110	**
GSX-R 750	2004-05	08656-95	300	246	9.5	01309	110	*/**
GSX-R 750	2004-05	08656-10	300	246	10.0	01309	110	**
GSX-R 750	2006-09	08724-90	300	267	9.0	01309	115	**
GSX-R 750	2006-09	08724-95	300	267	9.5	01309	115	*/**
GSX-R 750	2006-09	08724-10	300	267	10.0	01309	115	**
GSX-R 750	2011-14	08773-90	300	235	9.0	01309	75	***
GSX-R 750	2011-14	08773-10	300	235	10.0	01309	75	***
M 1500	2009	08862-01	300		prog. 5,25-20	***	135	
M 800	2005-09	08854-01	300		prog. 5,8-14	***	135	
M 800Z	2009	08854-01	300		prog. 5,8-14	***	135	
RF 600 R	1993-94	08622-80	300	400	8.0	01316	130	
SFV 650 Gladius	2009-14	08780-90	300	447	9.0	01309	105	**
SV 1000	2003-06	08695-90	300	297	9.0	01309	130	
SV 650	1999-02	08657-80	300	310	8.0	01316	130	*
SV 650	1999-02	08657-85	300	310	8.5	01316	130	
SV 650	2003-07	08698-80	300	428	8.0	01316	130	w/o ABS *
SV 650	2003-07	08698-85	300	428	8.5	01316	130	w/o ABS
TL 1000 S	1997-01	08651-85	300	285	8.5	01309	110	
VL 1500	1997-04	08856-01	300		prog. 4,5-15,3	***	180	
VL 800	2001-04	08853-01	300		prog. 4,5-14	***	195	
<b>TRIUMPH</b>								
Bonneville	2000-12	08798-90	300	315	9.0	01316	125	*
Daytona 675	2006-08	08727-85	300	242	8.5	01309	110	*
Daytona 675	2006-08	08727-90	300	242	9.0	01309	110	
Daytona 955i	1997-04	08635-85	300	250	8.5	01309	120	
Daytona 955i	1997-04	08635-90	300	250	9.0	01309	120	
Scrambler	2005-11	08798-90	300	315	9.0	01316	130	
Speed Triple 1050	2008-10	08770-95	300	280	9.5	01309	100	**
Sprint RS	2000	08658-80	300	410	8.0	01316	140	
Sprint ST	1999	08658-80	300	410	8.0	***	***	

Accessories MX & Enduro HD & Custom Road & Track Front Road & Track Rear Scooter Performance Line Street Performance Line



# FRONT SPRINGS

## ROAD&TRACK

Model	Year	Part No	P/C	Length	Rate N/mm	Rec. Öhlins Oil	Oil level (mm)	Notes
<b>TRIUMPH</b>								
Street Triple 675	2008-12	08693-90	300	258	9.0	01309	80	**
Street Triple 675	2008-12	08693-10	300	258	10.0	01309	80	**
Street Triple R 675	2009-12	08781-95	300	247	9.5	01309	100	**
Super III	1994-95	08832-01	300		8.0	01309	140	
T509 Speed Triple	1997-99	08635-85	300	250	8.5	01309	110	
T509 Speed Triple	1997-99	08635-90	300	250	9.0	01309	110	
T595 Daytona	1997-99	08635-85	300	250	8.5	01309	110	
T595 Daytona	1997-99	08635-90	300	250	9.0	01309	110	
Thruxton	2004-12	08797-90	300	330	9.0	01316	125	*
Thruxton	2004-12	08797-95	300	330	9.5	01316	125	
Thunderbird Sport	1998-99	08603-75	300	415	7.5	01309	140	
Tiger 1050	2007-12	08756-70	300	300	7.0	01309	120	
Tiger 800	2011-14	08403-65	300	362	6.5	01309	110	**
Tiger 800 XC	2011-14	08404-65	300	446	6.5	01309	120	**
Trophy 1200	1996-99	08800-01	300		8.0	01316	125	
Trophy 900	1996-99	08800-01	300		8.0	01316	125	
<b>YAMAHA</b>								
FJ 1200	1991-93	08608-90	300	510	9.0	01316	130	ABS
FJ 1200	1991-93	08608-90	300	510	9.0	01316	130	
FJR 1300	2001-12	08679-90	300	261	9.0	01309	110	*
FJR 1300	2001-12	08679-10	300	261	10.0	01309	110	
FZ 1	2006-07	08656-90	300	246	9.0	01309	92	**
FZ 1	2006-07	08656-95	300	246	9.5	01309	92	**
FZ 1	2006-07	08656-10	300	246	10.0	01309	92	**
FZ6	2004-07	08711-80	300	354	8.0	01316	107	*/**
FZ6	2004-07	08711-85	300	354	8.5	01316	107	**
FZ6 S2	2007-09	08711-80	300	354	8.0	01316	107	*/**
FZ6 S2	2007-09	08711-85	300	354	8.5	01316	107	**
FZ8	2010-13	08799-95	300	285	9.5	01309	85	**
FZS 1000 Fazer	2001-05	08675-85	300	343	8.5	01309	130	*
FZS 1000 Fazer	2001-05	08675-90	300	343	9.0	01309	130	
FZS 600 Fazer	1998-03	08807-01	300		8.0	01314	140	
MT 07	2014	08425-90	300	345	9.0	***	***	
MT 09	2014	08422-90	300	300	9.0	01309	145	**
MT 09	2014	08423-90	300	300	9.0	01309	160	For Cart-kit FGK 230
SR 400/500	1978-95	08640-50	300	516	5.0	01316	140	For drumbrake only
T135 LC4V		08791-60	300	298	6.0	***	***	
TDM 900	2002-03	08683-80	300	315	8.0	01316	160	
TDM 900	2004-12	08712-80	300	353	8.0	01316	140	
TRX 850	1996-00	08608-70	300	510	7.0	01316	130	
TRX 850	1996-00	08608-80	300	510	8.0	01316	130	
TRX 850	1996-00	08608-85	300	510	8.5	01316	130	
V-Max	1993-05	08676-70	300	370	7.0	01316	140	
XJ 6	2009-12	08783-85	300	365	8.5	01316	120	ABS **
XJ 900 S Diversion	1995-05	08818-01	300		8.0	01316	150	
XJR 1200	1995-98	08834-01	300		8.0	01316	150	
XJR 1300	1999-01	08660-80	300	390	8.0	01316	150	
XT 660 Z Ténére	2008-09	08716-60	300	590	6.0	01314	150	
XT 660X	2004-05	08716-60	300	590	6.0	***	***	
XV 1600 Wild Star	1999-05	08849-01	300		prog. 6,5-9,6	***	115	
XV 1700 Wild Star	2004-05	08849-01	300		prog. 6,5-9,6	***	115	
XV 1900A Midnight Star	2006-11	08851-01	300		prog. 7-18	***	140	
XVS 1100 Drag Star	1999-05	08846-01	300		prog. 4-8	***	125	
XVS 1100A Drag Star Classic	2000-07	08847-01	300		prog. 3,5-9	***	125	

## ROAD&TRACK

# FRONT SPRINGS

Model	Year	Part No	P/C	Length	Rate N/mm	Rec. Öhlins Oil	Oil level (mm)	Notes
XVS 1300A Midnight Star	2007-11	08848-01	300		prog. 5-11	***	110	
XVS 650 Drag Star	1997-04	08844-01	300		prog.4-4,6	***	110	
XVS 650A Drag Star Classic	1997-07	08845-01	300		prog. 4-5	***	110	
XVS 950A Midnight Star	2009-11	08863-01	300		prog. 4,3-8,5	***	110	
YZF 1000	1996-99	08632-90	300	290	9.0	01309	110	
YZF R1	1998-01	08649-80	300	255	8.0	01309	110	
YZF R1	2002-03	08681-90	300	250	9.0	01309	110	
YZF R1	2002-03	08681-95	300	250	9.5	01309	110	
YZF R1	2004-08	08672-95	300	235	9.5	01309	135	*/**
YZF R1	2004-08	08672-10	300	235	10.0	01309	135	**
YZF R1	2009-14	08774-95	300	273	9.5	01309	117	*/**
YZF R1	2009-14	08774-10	300	273	10.0	01309	117	**
YZF R6	2005	08714-95	300	250	9.5	01309	110	*
YZF R6	2005	08714-10	300	250	10.0	01309	110	
YZF R6	1999-02	08652-90	300	257	9.0	01309	110	
YZF R6	1999-02	08652-95	300	257	9.5	01309	110	
YZF R6	2003-04	08692-10	300	250	10.0	01309	120	
YZF R6	2006-07	08722-85	300	250	8,5	01309	110	
YZF R6	2006-07	08722-90	300	250	9.0	01309	110	
YZF R6	2006-07	08722-95	300	250	9,5	01309	110	
YZF R6	2006-07	08722-10	300	250	10.0	01309	110	
YZF R6	2008-14	08760-85	300	255	8,5	01309	103	*/**
YZF R6	2008-14	08760-90	300	255	9.0	01309	103	**
YZF R6	2008-14	08760-95	300	255	9,5	01309	103	**
YZF R6	2008-14	08760-10	300	255	10.0	01309	103	**

\*=recommended spring for normal use

\*\*=oil level measured without spring and/or pushertube

\*\*\*=according to vehicle service manual

## FRONT FORK SPRINGS FOR FKA KIT

Model	Part No	P/C	Length	Rate N/mm	Rec. Öhlins Oil	Oil level (mm)	Notes
<b>ÖHLINS</b>							
FKA 101	08767-50	300	480	5,0	01309	180	180
FKA 101	08767-55	300	480	5,5	01309	180	180
FKA 101	08767-60	300	480	6,0	01309	180	180
FKA 102	08415-60	300	350	6,0	01309	130	130
FKA 102	08415-65	300	350	6,5	01309	130	130
FKA 103	08416-55	300	400	5,5	01309	120	120
FKA 103	08416-60	300	400	6,0	01309	120	120
FKA 104	08410-65	300	328	6,5	01309	180	180
FKA 104	08410-70	300	328	7,0	01309	180	180
FKA 105	08418-55	300	450	5,5	01309	150	150
FKA 105	08418-60	300	450	6,0	01309	150	150
FKA 106	08424-80	300	420	8,0	01309	180	180
FKA 106	08424-90	300	420	9,0	01309	180	180





Model	Year	Part No	P/C	Stroke	Mounting Pos	Notes
<b>APRILIA</b>						
RSV 1000 R	2004-06	SD 175	40	65	OR	
<b>BMW</b>						
HP 4	2013-14	SD 038	40	68	OR	
R nineT	2014	SD 044	40	63	OR	
R 1200 R	2006-12	SD 037	40	68	OR	
S 1000 R	2014	SD 046	40	68	OR	
S 1000 RR	2010-11	SD 033	40	68	OR	
S 1000 RR	2012-14	SD 038	40	68	OR	
<b>DUCATI</b>						
748	1994-02	SD 031	44	68	OR	
848	2008-11	SD 197	46	63	OR	
848 EVO / EVO Corse	2011-13	SD 031	44	68	OR	
899 Panigale	2014	SD 040	40	68	OR	
916	1994-98	SD 031	44	68	OR	
996	1999-01	SD 031	44	68	OR	
998	2002-03	SD 031	44	68	OR	
1098	2007-08	SD 031	44	68	OR	
1198	2009-11	SD 031	44	68	OR	
1199 Panigale	2012-14	SD 040	40	68	OR	
Monster 1000	2003-07	SD 154	44	140	SI	

Model	Year	Part No	P/C	Stroke	Mounting Pos	Notes
Monster 620	2002-07	SD 154	44	140	SI	
Monster 695	2007	SD 154	44	140	SI	
Monster 750	2002	SD 154	44	140	SI	
Monster 800	2003-07	SD 154	44	140	SI	
Monster 900	2002	SD 154	44	140	SI	
Monster S2R 1000	2005-07	SD 154	44	140	SI	
Monster S2R 800	2005-07	SD 154	44	140	SI	
Monster S4	2001-07	SD 154	44	140	SI	
Monster S4R	2003-07	SD 154	44	140	SI	
Monster S4Rs	2006-07	SD 154	44	140	SI	

<b>HONDA</b>						
CBR 600 F	1999-02	SD 148	44	68	AC	
CBR 600 F Sport	2001-02	SD 148	44	68	AC	
CBR 600 RR	2003-04	SD 170	46	63	AC	

<b>KAWASAKI</b>						
ZX 10 R	2008-14	SD 021	40	65	OR	
ZX 6 R	2009-14	SD 021	40	65	OR	
ZX 6 R (636)	2013-14	SD 042	46	63	AC	

<b>SUZUKI</b>						
GSX 1300 R Hayabusa	1999-02	SD 143	46	63	AC	
GSX 1300 R Hayabusa	2008-12	SD 030	44	68	OR	
GSX-R 1000	2001-13	SD 030	44	68	OR	
GSX-R 1000	2003-04	SD 167	46	63	AC	
GSX-R 1000	2005-06	SD 181	46	63	AC	
GSX-R 600	2001-13	SD 030	44	68	OR	
GSX-R 600	2004-05	SD 176	46	63	AC	
GSX-R 750	2000-13	SD 030	44	68	OR	
GSX-R 750	2004-05	SD 176	46	63	AC	
TL 1000 R	1998-01	SD 137	40	68	AC	

<b>YAMAHA</b>						
FZ6	2004-08	SD 178	46	63	AC	
YZF R1	2004-08	SD 027	40	68	OR	
YZF R1	2009-14	SD 024	46	63	OR	
YZF R1-SP	2006	SD 027	40	68	OR	
YZF R1-M	2015	SD 043	42	60	OR, EC type	
YZF R1 / R1-M	2015	SD 047	40	63	OR	
YZF R6	2006-07	SD 183	46	63	AC	
YZF R6	2008-14	SD 020	46	63	AC	

AC = Across Mount SI = Side Mount OR = Original Mount

Model	Part No	P/C	Stroke	Mounting Length	Notes
<b>UNIVERSAL</b>					
Steering damper stroke 63	SD 000	40	63	36,5/223,5	
Steering damper stroke 68	SD 001	40	68	34,5/231,5	
Steering damper stroke 90	SD 002	40	90	34,5/275,5	
Steering damper stroke 120	SD 003	40	120	34,5/335,5	
Steering damper stroke 140	SD 004	42	140	34,5/375,5	
Steering damper stroke 150	SD 005	42	150	36,5/397,5	

See page 55 for Universal clamps.







## UNIVERSAL FG324/F424 FRONT FORK

A 43 mm upside down fork designed with custom builders in mind. Clean fork bottoms without a brake caliper design for applications with a left side brake only.

- 43 mm fork • Fully adjustable • Black and gold design • Setting can be changed with help from Öhlins Service Center



## UNIVERSAL RWU 43 FRONT FORK

Öhlins offers a 43 mm conventional universal fork for any custom builder that wants to give the bike supreme suspension yet classic style and at the same time get the familiar Öhlins Racing design.

- 43 mm fork • Fully adjustable • Black and gold design • Setting can be changed with help from Öhlins Service Center



## FKC100-SERIES CARTRIDGE KITS

Front end upgrade for the FLH and FLT Touring Baggers. This NIX-kit has rebound damping in one leg and compression damping in the other. This kit has been designed with a focus on vehicle control and a smooth ride.

- 25 mm pistons • Öhlins NIX technology • Aluminum damping tubes • Optional spring rates • Improved feel, control and comfort • Easy to install



## STX36 & STX36 BLACKLINE SHOCK ABSORBERS

Öhlins shock absorbers for Harley-Davidson and Custom are now available in two different designs, but with the same superior Öhlins comfort and performance underneath.

- Well proven monotube design • Designed for comfort and rideability • Each application tested and tailor made to suit • Wide range of spring rates are available



## FRONT END PRODUCTS

Model	Year	Part No	Type Code	P/C	Length	Stroke	Spring	Notes
<b>HARLEY-DAVIDSON</b>								
FLH/FLT	1997-13	FKC 101	25mm Cart. Kit NIX	12	677	117	*	Rec.springs 08419-10 not included.
FLH/FLT	1997-13	08865-01	Low. kit for FKC 101	302	-25mm	-25mm	x	Springs rate 13N/mm included
FLH/FLT	2014-15	FKC 102	25mm Cart. Kit NIX	12	736		*	Rec.springs 08866-01 10N/mm not incl.
FLH/FLT	2014-15	08866-02	Optional Spring FKC 102	300				Spring rate 12N/mm
FLH/FLT	2014-15	08866-03	Low. kit for FKC 102	302	-25mm	-25mm	x	Springs rate 13N/mm included

\*Delivered without spring, must be ordered separately. X = Springs included in kit.

## SHOCK ABSORBERS

Model	Year	Part No	Type Code	P/C	Length	Stroke	Spring	Notes
<b>HARLEY-DAVIDSON</b>								
FLH/FLT Motor Officer Special	2012-13	HD 357	S36HR1C1L	33	336+0/-10	90,5	00281-68 (B)	
FLHR	1995-15	HD 538	S36E	10	296	71	00360-06 (B)	
FLHR	1995-15	HD 539	S36E	10	296	71	00380-06 (Y)	
FLHR	1995-15	HD 540	S36E	10	296	71	21212-06 (C)	
FLHRC	1995-15	HD 159	S36DR1L	16	329 +5/-5	77	00280-21 (B)	
FLHRC	1995-15	HD 538	S36E	10	296	71	00360-06 (B)	

Model	Year	Part No	Type Code	P/C	Length	Stroke	Spring	Notes
FLHRC	1995-15	HD 539	S36E	10	296	71	00380-06 (Y)	
FLHRC	1995-15	HD 540	S36E	10	296	71	21212-06 (C)	
FLHRS	2004-15	HD 538	S36E	10	296	71	00360-06 (B)	
FLHRS	2004-15	HD 539	S36E	10	296	71	00380-06 (Y)	
FLHRS	2004-15	HD 540	S36E	10	296	71	21212-06 (C)	
FLHT	1990-15	HD 022	S36E	9	330	84	00281-68 (B)	
FLHT	1990-15	HD 538	S36E	10	296	71	00360-06 (B)	
FLHT	1990-15	HD 539	S36E	10	296	71	00380-06 (Y)	
FLHT	1990-15	HD 540	S36E	10	296	71	21212-06 (C)	
FLHT	2006-15	HD 039	S36E	9	309,5	83	21180-01 (B)	
FLHTC	1988-04	HD 538	S36E	10	296	71	00360-06 (B)	
FLHTC / FLHTCU	1988-04	HD 539	S36E	10	296	71	00380-06 (Y)	
FLHTC	1988-04	HD 540	S36E	10	296	71	21212-06 (C)	
FLHTCU	1988-08	HD 538	S36E	10	296	71	00360-06 (B)	
FLHTCU	1988-08	HD 540	S36E	10	296	71	21212-06 (C)	
FLHX	2006-08	HD 538	S36E	10	296	71	00360-06 (B)	
FLHX	2006-08	HD 539	S36E	10	296	71	00380-06 (Y)	
FLHX	2006-08	HD 540	S36E	10	296	71	21212-06 (C)	
FLT	1998-12	HD 159	S36DR1L	16	329 +5/-5	77	00280-21 (B)	
FL Touring Black Line	1990-15	HD 771	S36D	13	305	72	00360-06 (B)	
FL Touring Black Line	1990-15	HD 772	S36DR1L	17	329 +5/-5	77	00280-21 (B)	
FL Touring Black Line	1990-15	HD 773	S36D	13	329	92	00281-68 (B)	
FXD Dyna	1991-15	HD 215	S36PR1C1LB	33	340 +5/-5	88	21180-01 (B)	
FXD Dyna	1991-15	HD 216	S36E	9	305	65	21180-01 (B)	
FXD Dyna	1991-15	HD 218	S36K	21	305	66	03195-08 (C)	
FXD Dyna	1991-15	HD 219	S36PR1C1LB	33	305 +10/-0	64	00281-66 (B)	
FXD Dyna	1991-15	HD 220	S36E	9	340	88	21180-01 (B)	
FXD Dyna	1991-15	HD 616	S36E	9	305	66	21210-23 (C)	
FXD Dyna	1991-15	HD 816	S36DR1L	16	325 +5/-5	67	21180-01 (B)	
FXD Dyna	1991-15	HD 817	S36DR1	15	305	61	21180-01 (B)	
FXD Dyna Black Line	1991-15	HD 761	S36D	13	305	62	00281-66 (B)	
FXD Dyna Black Line	1991-15	HD 762	S36DR1L	17	305 +10/-0	61	00281-66 (B)	
FXD Dyna Black Line	1991-15	HD 763	S36PR1C1L	30	305 +10/-0	64	00281-66 (B)	
VRSCA V-Rod	2002-06	HD 928	S36DR1L	16	318 +10/-0	67	00181-05 (B)	
VRSCB V-Rod	2004-05	HD 928	S36DR1L	16	318 +10/-0	67	00181-05 (B)	
V-Rod Black Line		HD 781	S36DR1L	17	325 +5/-5	68	00181-05 (B)	
VRSCDX Night Rod Special	2007-12	HD 928	S36DR1L	16	318 +10/-0	67	00181-05 (B)	
XL Sportster	2004-15	HD 141	S36PL	16	336 +10/-0	98	00480-02 (B)	
XL Sportster	2004-15	HD 142	S36PL	16	360 +10/-0	100	00480-01 (B)	
XL Sportster	2004-15	HD 143	S36PR1C1LB	33	336 +10/-0	95	00380-04 (Y)	
XL Sportster	2004-15	HD 144	S36PR1C1LB	33	360 +10/-0	101	00480-11 (Y)	
XL Sportster	2004-15	HD 145E	S36E	9	296	71	00360-04 (B)	
XL Sportster	2004-15	HD 146	S36E	9	360,5	105	00480-01 (B)	
XL Sportster	2004-15	HD 645	S36E	9	296	71	00380-04 (Y)	
XL Sportster	2004-15	HD 716	S36E	9	337	104	21211-02 (C)	
XL Sportster	2004-15	HD 745	S36E	9	296	71	21212-04 (C)	
XL Sportster	2004-15	HD 906	S36DR1L	16	336 +10/-0	77	00480-02 (B)	
XL Sportster	2004-15	HD 916E	S36E	9	337	104	00480-02 (B)	
XL Sportster Black Line	2004-15	HD 751	S36D	13	296	71	00360-04 (B)	
XL Sportster Black Line	2004-15	HD 752	S36PR1C1L	30	296 +10/-0	72		
XL Sportster Black Line	2004-15	HD 753	S36DR1L	17	336 +10/-0	75	00480-02 (B)	
XL Sportster Black Line	2004-15	HD 754	S36E	11	338	97	00480-02 (B)	
XL Sportster Black Line	2004-15	HD 755	S36D	13	360	103	00480-01 (B)	
XR 1200	2004-13	HD 852	S36PR1C1L	25	415 +5/-5	98	06380-04 (Y)	
XR 1200	2004-13	HD 907	S36PL	16	360 +10/-0	97	00480-02 (B)	
XR 1200	2004-13	HD 908	S36PL	16	360 +10/-0	97	00480-12 (Y)	





By using Öhlins TTX shock absorbers and the NIX technology on front forks, we can add electronic adjustments to the motorcycle suspension. To make a true improvement, the algorithms used to control the chassis balance, need to be at a very sophisticated level. Since we develop our own software based on motorcycle chassis knowledge since 40 years, we can make true semi active suspension to more and more bike models. It is as if you had an Öhlins technician onboard during the ride, adjusting the clickers.



We also develop our own suspension control units (SCU) as well as our own Man Machine Interface (MMI) – the Öhlins Dashboard.

## SUSPENSION CONTROL UNIT - SCU

No semi active suspension is better than its algorithms that control the adjusters. The Öhlins SCU reads different bike parameters, such as throttle control, speed, braking etc. If available on the bike, also movement sideways, lean angles and so on, from the bike sensor box. All signals are taken into consideration, and the best click setting for the riding situation at the moment, is adjusted.



Needless to say, the Öhlins SCU are designed to fulfill automotive standards in terms of temperature, vibrations, moisture and dirt. CAN bus communication is used whenever possible on the bike application.

## KAWASAKI ZX-10R

Since 2013, the Ninja comes with a semi active steering damper ex-factory. For track day riders and high level racers that want to use the electronically controlled steering damper, we offer a race SCU. The Algorithms used in the Race SCU, give racing performance to the steering damper. Not for highway use!



The TTX36 EC shock absorber is also available to the ZX-10R, with semiactive control, totally based on riding behavior. If you ride calm, you get a lot of comfort and if you ride very fast you get the racing setting to match your riding style. The Öhlins Race Wiring harness, is intended to be used in combination with the Kawasaki Racing tuning kit.

## ÖHLINS DASHBOARD

Depending on application, we can also offer the Öhlins Dashboard as MMI to control the suspension adjustment. The Öhlins Dashboard utilize a touch screen that can be controlled while riding – with gloves – to change riding modes. Individualization of click settings, driving dynamics and more features can be adjusted.

The Öhlins Dashboard is standard on the Ducati 870 kits, and can be an option to the BMW 670/671 kits. More applications to come.



## MULTISTRADA 1200 MECHATRONICS KIT - DU 870

The complete kit to all Multistrada owners who want to update the bike from standard OEM suspension, into a full Öhlins semi active system. Consists of complete front fork, rear shock absorber, Öhlins Dashboard and the upgrade suspension control unit. Of course also with all necessary wiring, brackets, bits and pieces to make it fit the bike.



- TiN coated fork inner tubes, complete front fork
- Rear shock absorber with TTX technology and electronically
- Öhlins Semiactive suspension SCU
- Öhlins Dashboard for control
- All installation parts included

## BMW R 1200 GS MECHATRONICS KIT - BM 670/671

The successful mechatronics kit to the air cooled beamer is now being offered to all GS year models. Before the bikes needed to have ESA functions from the factory.

With the introduction of the Öhlins Dashboard as an accessory to the BMW kits, it can be fitted to any BMW R 1200 GS or GS adventure between 2004-2012. And ESA is no longer important.



- TTX technology shock absorbers
  - Semiactive functions, speed dependent setting
  - With ESA on the bike, it can be operated with the ESA button
  - Without ESA, the system is operated with the Öhlins Dashboard
  - The Öhlins Dashboard offers extended features to the rider compared to ESA
  - Öhlins Dashboard available during 2014.
- See [www.ohlins.com](http://www.ohlins.com)

Model	Year	Part No	P/C	Description	Notes
<b>BMW</b>					
R 1200 GS	2008-12	BM 670		Mechatronics Suspension Kit	
R 1200 GSA	2008-13	BM 671		Mechatronics Suspension Kit	
R 1200 GS/GSA	2004-12	35007-01		Dashboard accessory BM 670/671	Requires wire harness Ver. 21770-01
<b>DUCATI</b>					
Multistrada 1200	2010-12	DU 871		Complete Öhlins Mechatronic Kit	
Multistrada 1200S	2010-12	35000-03		SCU Duc MTS1200S Upgrade	
<b>KAWASAKI</b>					
ZX-10R	2011-12	21740-02		SCU SA EC-system ZX10R AM	
ZX-10R	2013-14	21740-03		SCU SD EC-system ZX10R AM-Racing	For race use only
ZX-10R	2011-14	21770-51		Wire harness SD ZX10 Race ECU	In comb w. KHI race kit







Note! Your shock absorber may look different from the one on the image above. The reservoir may be angled to fit your bike and a horizontal reservoir is used on some models.

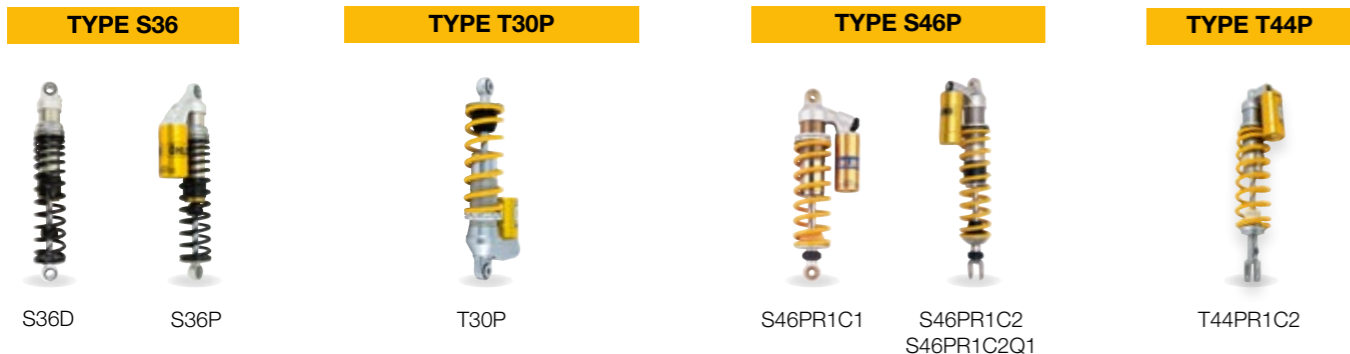

## MX & ENDURO

# SHOCK ABSORBERS

Model	Year	Part No	Type Code	P/C	Length	Stroke	Spring	Notes
<b>HONDA</b>								
CRF 150 R	2007-15	HO 990	T44PR1C1W	21	427	105	*	06320- series spring
CRF 250 R	2014-15	HO 1593	T44PR1C2W	225	479	133	*	06310- series spring
CRF 450 R	2013-15	HO 1594	T44PR1C2W	225	479	133	*	06310- series spring
<b>HUSQVARNA</b>								
FC 250/350	2014-15	KT 1593	T44PR1C2W	225	490	126	*	06310- series spring
FC 450	2014-15	KT 1594	T44PR1C2W	225	490	126	*	06310- series spring
FE 250/350/450/501	2014-15	KT 1593	T44PR1C2W	225	490	126	*	06310- series spring
TC 125/250/	2014-15	KT 1593	T44PR1C2W	225	490	126	*	06310- series spring
TC 85 High/Low	2014-15	KT 1490	S46PR1C2Q1W	225	397	96	*	00698- series spring
TE 125/250/300	2014-15	KT 1593	T44PR1C2W	225	490	126	*	06310- series spring
<b>KAWASAKI</b>								
KX 65	2002-11	KA 797	S36PR1C1	12	349	89	00281-56	00281- series spring
KX 85	2010-15	KA 1490	S46PR1C2W	19	378	109	*	00698- series spring
KLX 110	2002-05	KA 488	S36DW	2	255	60	*	00180- series spring
KX 250F	2009-15	KA 1593	T44PR1C2W	225	486	131	*	06310- series spring
KX 450F	2009-15	KA 1594	T44PR1C2W	225	486	131	*	06310- series spring
<b>KTM</b>								
50 SX	2012-15	KT 1397	T30PR1C1W	15	276	72	*	00281- series spring
65 SX	2012-15	KT 1398	T30PR1C1W	15	348	103	*	00181- series spring
85 SX (17/14)	2013-15	KT 1490	S46PR1C2Q1W	225	397	96	*	00698- series spring
85 SX (19/16)	2013-15	KT 1490	S46PR1C2Q1W	225	397	96	*	00698- series spring
125/150/250 SX	2013-15	KT 1593	T44PR1C2W	225	490	126	*	06310- series spring
250/350 SX-F	2011-15	KT 1593	T44PR1C2W	225	490	126	*	06310- series spring
450 SX-F	2011-15	KT 1594	T44PR1C2W	225	490	126	*	06310- series spring
XC/XC-F	2015	KT 1593	T44PR1C2Q1W	225	490	126	*	06310- series spring
125/200/250/300 EXC	2012-15	KT 1584	T44PR1C2Q1W	245	419	105	*	06320- series spring
250/350 EXC-F	2012-15	KT 1584	T44PR1C2Q1W	245	419	105	*	06320- series spring
450/500 EXC-F	2012-15	KT 1584	T44PR1C2Q1W	245	419	105	*	06320- series spring
125/250/300 EXC Six Days	2012-15	KT 1584	T44PR1C2Q1W	245	419	105	*	06320- series spring
250/350 EXC-F Six Days	2012-15	KT 1584	T44PR1C2Q1W	245	419	105	*	06320- series spring
450/500 EXC-F Six Days	2012-15	KT 1584	T44PR1C2Q1W	245	419	105	*	06320- series spring
<b>SUZUKI</b>								
RM 65	2003-07	KA 797	S36PR1C1	12	349	89	00281-56	
RM 85	2005-15	SU 1490	S46PR1C2W	19	397	107	*	00698- series spring
RM-Z 110	2002-05	KA 488	S36DW	2	255	60	*	00180- series spring
RM-Z 250	2007-15	SU 1593	T44PR1C2W	225	480	126	*	06310- series spring
RM-Z 450	2005-15	SU 1594	T44PR1C2W	225	480	126	*	06310- series spring
<b>YAMAHA</b>								
YZ 85	2002-15	YA 1390	S46PR1C2W	19	403	104	*	00698- series spring
WR 450 F	2012-15	YA 1484	T44PR1C2W	225	490	120	*	06310- series spring
YZ 125/250 2stroke	2013-15	YA 1492	T44PR1C2W	225	491	126	*	06310- series spring
YZ 250/465	1980-81	YA 367	S46HR1	20	542	161	05174-09	05174- series spring
YZ 250 F	2014-15	YA 1593	T44PR1C2W	225	458	121	*	06310- series spring
YZ 450 F	2014-15	YA 1594	T44PR1C2W	225	458	121	*	06310- series spring

\*Delivered without spring, must be ordered separately.



## TTX44 MX

Motocross and Enduro are the ultimate tests for the R&D department and it's where it all started for us. That is why we are so serious about it. The oil flows through two Öhlins Gold valves in the compression adjusters at the top of the shock. The TTX44 also includes the Öhlins cool tool.

- Twin tube design • Öhlins TTX technology • Rigid, fine precision rebound adjuster • Three level high speed adjuster • Highly effective low speed compression adjuster • Race type piston and pistonband • Dual spring kit available to most models • Available for all major MX and Enduro models • New surface treatment piston rod • Öhlins Cool tool

## STX46 MX

An updated 46 mm shock absorber from Öhlins, perfectly suited for 85cc bikes and OE applications. The 2-way compression adjuster is new and similar to the Öhlins TTX shocks for the larger bikes.

- Two way compression adjuster • Wide range of low speed compression adjustment, 3 click high speed • Improved dynamics, equals better function • Upgraded PDS function

## TTX30 MX

The Öhlins MX shock absorber for the 50/65 cc bikes, the first Öhlins TTX shock for the small bike segment.

- Öhlins TTX technology • Full maintenance and service capability • Size perfect for 50/65 cc bikes • Wide range of springs available

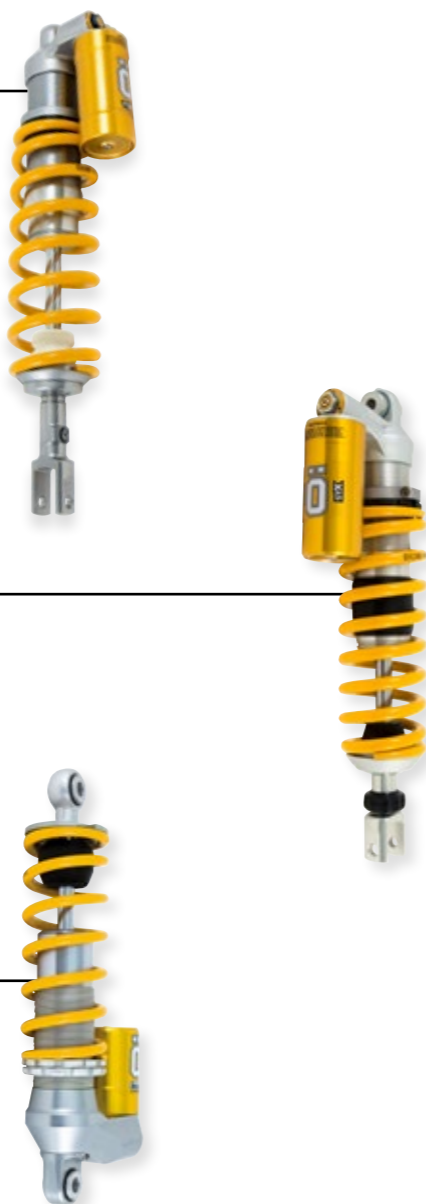

## COOL TOOL TTX44

24614-02

Cool Tool TTX44





Part No	Length	Inner diam.	Wire diam.	Rate N/mm	Maximum stroke
<b>00180-SERIES</b>					
00180-85	180	46	8	36	100
00180-57	180	46	8,25	41	97
00180-67	170	46	8,5	45	91
00180-88	180	46	9	52	94
00180-90	230	46		12-14,3 Prog.	
<b>00181-SERIES</b>					
00181-09	200	46	8,5	35	110
00181-10	200	46	8,75	40	110
00181-11	210	46	9,25	45	110
<b>00281-SERIES</b>					
00281-11	125	46	7	30	74,3
00281-23	125	46	7,25	35	73,7
00281-12	125	46	7,5	40	72,4
<b>00480-SERIES</b>					
00480-01				15-24 Prog.	
<b>00596-SERIES</b>					
00596-08	270	57	11	48	151
00596-09	270	57	11	50	145
00596-10	270	57	11,25	52	147
00596-11	270	57	11,25	54	143
00596-12	270	57	11,5	56	140
00596-13	270	57	11,5	58	141
<b>00698-SERIES</b>					
00698-90	230	57	9	32	132
00698-01	230	57	9,5	34	133
00698-02	230	57	9,75	36	128
00698-03	230	57	9,75	38	132
00698-04	230	57	9,75	40	129
00698-05	230	57	10	42	131
00698-06	230	57	10	44	130
00698-07	230	57	10,25	46	129
00698-08	230	57	10,25	48	128
00698-09	230	57	10,5	50	126
00698-10	230	57	10,5	52	126
00698-11	230	57	10,5	54	121
00698-12	230	57	10,5	56	116
<b>05174-SERIES</b>					
005174-09				35	

# SPRINGS

Part No Colour	Length	Inner diameter	Outer diameter	Wire diameter	Rate N/mm	Maximum Stroke
06310-01Y	225	61-65	80,5-84,5	9,75	34	140
06310-02Y	230	61-65	81-85	10	36	140
06310-03Y	230	61-65	81-85	10,25	38	140
06310-04Y	235	61-65	81,5-85,5	10,5	40	140
06310-05Y	235	61-65	82-86	10,5	42	140
06310-06Y	240	61-65	82,5-86,5	10,75	44	140
06310-07Y	235	61-65	82,5-86,5	10,75	46	140

Part No Colour	Length	Inner diameter	Outer diameter	Wire diameter	Rate N/mm	Maximum Stroke
06310-08Y	240	61-65	83-87	11	48	140
06310-09Y	245	61-65	83-87	11,25	50	140
06310-10Y	245	61-65	83,5-87,5	11,25	52	140
06310-11Y	250	61-65	84-88	11,5	54	140
06310-12Y	250	61-65	84-88	11,5	56	140
06310-13Y	255	61-65	84,5-88,5	11,75	58	140
06310-14Y	260	61-65	85-89	12	60	140
06310-15Y	255	61-65	85-89	12	62	140
06310-16Y	265	61-65	85,5-89,5	12,25	64	140
06320-08Y	205	61-65	81,5-85,5	10,5	48	120
06320-09Y	200	61-65	82-86	10,5	50	120
06320-10Y	205	61-65	82,5-86,5	10,75	52	120
06320-11Y	205	61-65	82,5-86,5	10,75	54	120
06320-12Y	215	61-65	82,5-86,5	10,75	56	120
06320-13Y	215	61-65	83-87	11,25	58	120
06320-14Y	215	61-65	83,5-87,5	11,25	60	120
06320-15Y	210	61-65	83,5-87,5	11,25	62	120
06320-16Y	215	61-65	84-88	11,5	64	120
06320-17Y	215	61-65	84,5-88,5	11,5	66	120
06320-18Y	220	61-65	84,5-88,5	11,75	68	120
06320-19Y	225	61-65	85-89	12	70	120
06320-20Y	225	61-65	85-89	12	72	120
06320-21Y	230	61-65	85,5-89,5	12,25	75	120
06320-24Y	235	61-65	86-90	12,5	80	120
06320-26Y	235	61-65	86,5-90,5	12,75	85	120
06320-29Y	240	61-65	87-91	13	90	120
06320-31Y	245	61-65	87,5-91,5	13,25	95	120
06320-39Y	260	61-65	89-93	14	110	120
06410-06Y	265	66	88	11	44	150
06410-07Y	265	66	88,5	11,25	46	150
06410-10Y	265	66	89	11,5	52	150
06410-13Y	265	66	90	12	58	150
06410-14Y	265	66	90,5	12,25	60	150
06410-15Y	265	66	91	12,5	62	150
06411-07Y	255	63,5-65,5	85,5-87,5	11	46	145
06411-08Y	255	63,5-65,5	86-88	11,25	48	145
06411-09Y	255	63,5-65,5	86-88	11,25	50	145
06411-10Y	255	63,5-65,5	86,5-88,5	11,5	52	145
06411-11Y	255	63,5-65,5	86,5-88,5	11,5	54	140
06411-12Y	255	63,5-65,5	87-89	11,75	56	140
06411-13Y	255	63,5-65,5	87-89	11,75	58	140
06411-14Y	255	63,5-65,5	87,5-89,5	12	60	140
06411-15Y	255	63,5-65,5	87,5-89,5	12	62	140
06420-13Y	250	63	86	11,5	58	120
06420-14Y	250	63	86	11,5	60	120
06420-15Y	250	63	86,5	11,75	62	120
06420-16Y	250	63	86,5	11,75	64	120
06420-17Y	250	63	87	12	66	120
06420-18Y	250	63	87	12	68	120
06420-19Y	250	63	87	12	70	120
06420-21Y	250	63	87,5	12,25	75	120
06420-24Y	250	63	88	12,5	80	120
06420-26Y	250	63	88,5	12,75	85	120



# SPRING GUIDE FOR STANDARD SHOCKS

MX & ENDURO

Model	Year	Spring series
<b>HONDA</b>		
CRF 250R	2010-2014	06411-XX
CRF 450R	2009-2014	06411-XX
<b>HUSABERG</b>		
TE 250/300	2011-2013	06320-XX
FE 350/390/450/501	2011-2013	06320-XX
<b>HUSQVARNA</b>		
TE 250/ 310/ 449/ 450/ 510	2010-2012	06310-XX
TC 250/ 450	2010-2012	06310-XX
<b>KAWASAKI</b>		
KLX 450 R	2011-2012	06411-XX
KX 250F/450F	2011-2014	06411-XX
<b>KTM</b>		
125/150 SX	2013-2014	06310-XX
250 SX	2011-2014	06310-XX
250/350/450 SX-F	2011-2014	06310-XX
EXC 125/200/250/300	2011-2014	06320-XX
EXC 250/350/450/500F	2011-2014	06320-XX
<b>SUZUKI</b>		
RM-Z 250/450	2010-2014	06411-XX
<b>YAMAHA</b>		
WR 250/450F	2011-2013	06411-XX
YZ 125/250	2013-2015	06411-XX
YZ 250F	2009-2013	06411-XX
YZ 450F	2010-2014	06411-XX

Springs found in table on page 44-45.

# VINTAGE SHOCK ABSORBERS

Model	Part No	Type Code	P/C	Length	Stroke	Spring
<b>VINTAGE</b>						
Classic MX	CC 606	S36D	13	360	107	00180-90
Classic MX	CC 607	S36D	13	340	105	00180-90
Classic MX	CC 718	S36P	13	380,5	107	00480-01



The Vintage shock absorbers are also suitable for classic road racing bikes, by using the shocks with the stiffer springs (00480-01)

# ATV SHOCK ABSORBERS KIT

Model	Part No	Type Code	P/C	Length	Stroke	Spring
<b>ATV-KIT</b>						
ATV Racing Kit	AT 071	T30PR1C1W	30	428	126	*
ATV Racing Kit	AT 072	T30PR1C1W	30	463	142	*
ATV Racing Kit	AT 073	T30PR1C1W	30	499	161	*
ATV Racing Kit	AT 074	T30PR1C1W	30	535	159	*

MX & ENDURO

# MX STEERING DAMPER 2.1

Since 1992, evolution of technological solutions has been added to the design throughout the years. The new steering damper is now equipped with a completely new valving system, eliminating any fluctuation of the damping characteristics depending on making a left or a right turn. The new UniFlow feature is actually a system that controls the flow of the hydraulic fluid into only

one direction hence the new fluctuation free damping curve. The system is also pressurized to compensate any temperature changes. The new easy way of mounting the damper broadens the list of MX bikes that can be fitted with this new model. Since 2013, the damper body is offered separately from the mounting kit.

- Damping Level Adjuster (DL) - Controls the general setup, including a high speed valve
- Return To Centre Adjuster (RTC) - Variable setup of the damping force on the return
- All aluminium casing
- Mounting Kit included
- Available for Honda, Kawasaki, KTM, Suzuki, Yamaha, Gas Gas, Husaberg and Husqvarna



ALL MODELS USES SAME DAMPER BODY SD 502

Model	Year	Mounting kit - Part No	P/C	Notes	Damper body - Part No	P/C	Notes
<b>GAS GAS</b>							
EC 250	2009-10	SD 572	1		SD 502	43	
EC 300	2009-10	SD 572	1		SD 502	43	
EC 300 2T	2013-14	SD 573	1		SD 502	43	
EC 450	2009-10	SD 572	1		SD 502	43	
EC 515	2009-10	SD 572	1		SD 502	43	
<b>HONDA</b>							
CRF 250R	2007-09	SD 513	1		SD 502	43	
CRF 250R	2010-15	SD 514	1		SD 502	43	
CRF 250X	2010	SD 513	1		SD 502	43	
CRF 450R	2008	SD 513	1		SD 502	43	
CRF 450R	2009-14	SD 514	1		SD 502	43	
CRF 450X	2010	SD 513	1		SD 502	43	
<b>HUSABERG</b>							
FE TE all models	2010-11	SD 534	1		SD 502	43	
<b>HUSQVARNA</b>							
TC 250/450	2010	SD 582	1		SD 502	43	
TC 449	2011	SD 582	1		SD 502	43	
TE 250/310	2010-11	SD 582	1		SD 502	43	
TE 449	2011	SD 582	1		SD 502	43	
TE 450/510	2010	SD 582	1		SD 502	43	
<b>KAWASAKI</b>							
KX 250F	2008-15	SD 522	1		SD 502	43	
KX 450F	2008-14	SD 522	1		SD 502	43	
KLX 450 R	2009-10	SD 522	1		SD 502	43	
<b>KTM</b>							
200-250-300 XC	2008-09	SD 534	1		SD 502	43	
200-250-300-400-450-530 EXC	2008-12	SD 534	1	Std triple clamp	SD 502	43	
200-250-300-400-450-530 XC-W	2008-09	SD 534	1		SD 502	43	
250 EXC-F	2008-12	SD 534	1	Std triple clamp	SD 502	43	
250 XCF-W	2008-09	SD 534	1		SD 502	43	
250-450SX-F	2008-12	SD 534	1	Std triple clamp	SD 502	43	
250SX	2008-12	SD 534	1	Std triple clamp	SD 502	43	
250 SX-F	2014	SD 535					
350 SX-F	2014	SD 535	1		SD 502	43	
450 SX-F	2014	SD 535					
EXC all models	2013-14	SD 535	1		SD 502	43	



# MX STEERING DAMPER 2.1

MX & ENDURO

Model	Year	Mounting kit -			Damper body -		
		Part No	P/C	Notes	Part No	P/C	Notes
<b>SUZUKI</b>							
RM-Z 250	2008-14	SD 543	1		SD 502	43	
RM-Z 450	2008-14	SD 543	1		SD 502	43	
<b>YAMAHA</b>							
YZ 125	2013	SD 554	1		SD 502	43	
YZ 250F	2008-14	SD 554	1		SD 502	43	
YZ 450F	2008-14	SD 554	1		SD 502	43	
WR 250F	2009-10	SD 555	1		SD 502	43	
WR 450F	2009-13	SD 555	1		SD 502	43	

# DUAL SPRING KITS

The Dual Spring Kits are developed one step further with new mixes of main and tenders spring to further improve the bike performance in rough conditions and enduro.

Part No.	Standard spring	Springs	Inner Ø (mm)	Free length (mm)	Rate (N/mm)	Notes
<b>DUAL SPRING KIT</b>						
DSK 008	06310-08, 48N/mm	06320-10/Main	61	205	52	
		15021-15/Tender	61	45	150	
DSK 009	06310-09, 50N/mm	06320-11/Main	61	205	54	
		15021-15/Tender	61	45	150	
DSK 0010	06310-10, 52N/mm	06320-12/Main	61	215	56	
		15021-20/Tender	61	45	200	
DSK 0011	06310-11, 54N/mm	06320-13/Main	61	215	58	
		15021-20/Tender	61	45	200	
DSK 0012	06310-12, 56N/mm	06320-14/Main	61	215	60	
		15021-20/Tender	61	45	200	
DSK 0013	06310-13, 58N/mm	06320-15/Main	61	210	62	
		15021-20/Tender	61	45	200	
DSK 0014	06310-14, 60N/mm	06320-16/Main	61	215	64	
		15021-20/Tender	61	45	200	
DSK 0015	06310-15, 62N/mm	06320-17/Main	61	215	66	
		15021-20/Tender	61	45	200	
<b>For KTM PDS</b>						
DSK 0016	06320-19, 70N/mm	06330-24/Main	61	190	80	
		15021-20/Tender	61	45	200	
DSK 0017	06320-21, 75N/mm	06330-29/Main	61	200	90	
		15021-20/Tender	61	45	200	
DSK 0018	06320-24, 80N/mm	06330-31/Main	61	200	95	
		15021-20/Tender	61	45	200	



MX & ENDURO

OFF-ROAD FRONT END PRODUCTS

2015

Model	Year	Part No	Type Code	P/C	Length	Stroke	Spring	Notes
<b>HONDA</b>								
CRF 150R	2013-15	FGHO 1390	Cartridge kit	106	844	274	*	For STD bike only Rec.08785-series
CRF 250R	2010-14	FGHO 1493	TTX Cartridge kit	106	941	311	*	08775-series spring
CRF 250R	2015	FGHO 1593	TTX Cartridge kit	245	939	304	*	08775-Series spring
CRF 250R	2015	FGHO 1596	RXF 48	1155	940	310	02428-49	08765-series spring
CRF 450R	2015	FGHO 1594	TTX Cartridge kit	245	945	309	*	08765-series spring
CRF 450R	2015	FGHO 1596	RXF 48	1155	940	310	02428-49	08765-series spring
<b>HUSQVARNA</b>								
FC 250/350/450	2015	FGKT 1596	RXF 48	1155	944	303	02428-49	08765-series spring
FC 250/350	2015	FGHA 1593	TTX Cartridge kit	245	952	304	*	08765-series spring
FC 450	2015	FGHA 1594	TTX Cartridge kit	245	952	304	*	08765-series spring
FE 250/350/450/501	2014-15	FGKT 1586	RXF 48	1155	940	299	02428-45	08765-series spring
FE 250/350/450/501	2014-15	FGKT 1585	TTX Cartridge kit	245	952	304	*	08765-series spring
TC 125/250	2015	FGHA 1593	TTX Cartridge kit	245	952	304	*	08765-series spring
TC 125/250	2015	FGKT 1596	RXF 48	1155	944	303	02428-49	08765-series spring
TC 85 High/Low	2014-15	FGKT 1490	TTX Cartridge kit	106	845	274	*	08789-series spring
TE 125/250/300	2014-15	FGKT 1586	RXF 48	1155	940	299	02428-45	08765-series spring
TE 125/250/300	2014-15	FGKT 1585	TTX Cartridge kit	245	952	304	*	08765-series spring
<b>KAWASAKI</b>								
KX 250 F	2013-14	FGKA 1493	TTX Cartridge kit	106	947	307	*	08765-series spring
KX 250 F	2015	FGKA 1593	TTX Cartridge kit	245	942	302	*	08765-series spring
KX 250 F	2013-15	FGKA 1596	RXF 48	1155	946	304	02428-49	08765-series spring
KX 450 F	2015	FGKA 1594	TTX Cartridge kit	245	943	302	*	08765-series spring
KX 450 F	2009-15	FGKA 1596	RXF 48	1155	946	304	02428-49	08765-series spring
KX 85	2009-15	FGKA 1390	Cartridge kit	106	831	270	*	08794-series spring
<b>KTM</b>								
125/150/250 SX Europe	2012-15	FGKT 1593	TTX Cartridge kit	245	948	307	*	08765-series spring
125/150/250 SX USA/CAN/AUS/NZ/MEX	2015	FGHA 1593	TTX Cartridge kit	245	952	304	*	08765-series spring
125/150/250 SX USA/CAN/AUS/NZ/MEX	2012-14	FGKT 1593	TTX Cartridge kit	245	948	307	*	08765-series spring
125/150/250 SX	2015	FGKT 1596	RXF 48	1155	944	303	02428-49	08765-series spring
EXC/EXC-F European model	2012-15	FGKT 1584	TTX Cartridge kit	245	950	302	*	08765-series spring
EXC/EXC-F European model	2012-15	FGKT 1586	RXF 48	1155	940	299	02428-45	08765-series spring
Sixdays Europe	2012-15	FGKT 1585	TTX Cartridge kit	245	952	304	*	08765-series spring
Sixdays Europe	2012-15	FGKT 1586	RXF 48	1155	940	299	02428-45	08765-series spring
EXC/EXC-F/XC-W and XCF-W USA/CAN/AUS/NZ/MEX	2012-15	FGKT 1584	TTX Cartridge kit	245	950	302	*	08765-series spring
EXC/EXC-F/XC-W and XCF-W USA/CAN/AUS/NZ/MEX	2012-15	FGKT 1586	RXF 48	1155	940	299	02428-45	08765-series spring
XC/XC-F USA/CAN/AUS/NZ/MEX	2015	FGKT 1585	TTX Cartridge kit	245	952	304	*	08765-series spring
XC/XC-F USA/CAN/AUS/NZ/MEX	2015	FGKT 1596	RXF 48	1155	944	303	02428-49	08765-series spring
250/350 SX-F Europe	2012-15	FGKT 1593	TTX Cartridge kit	245	948	307	*	08765-series spring
250/350 SX-F USA/CAN/AUS/NZ/MEX	2015	FGHA 1593	TTX Cartridge kit	245	952	304	*	08765-series spring



# FRONT END PRODUCTS

## MX & ENDURO

Model	Year	Part No	Type Code	P/C	Length	Stroke	Spring	Notes
<b>KTM</b>								
250/350 SX-F USA/CAN/AUS/NZ/MEX	2012-2014	FGKT 1593	TTX Cartridge kit	245	948	307	*	08765-series spring
250/350/450 SX-F	2015	FGKT 1596	RXF 48	1155	944	303	02428-49	08765-series spring
450 SX-F	2009-14	FGKT 1494	TTX Cartridge kit	106	948	307	*	08765-series spring
450 SX-F Europe	2012-15	FGKT 1594	TTX Cartridge kit	245	948	307	*	08765-series spring
450 SX-F USA/CAN/AUS/NZ/MEX	2015	FGHA 1594	TTX Cartridge kit	245	952	304	*	08765-series spring
450 SX-F USA/CAN/AUS/NZ/MEX	2012-14	FGKT 1594	TTX Cartridge kit	245	948	307	*	08765-series spring
450/500 EXC-F	2015	FGKT 1584	TTX Cartridge kit	245	950	302	*	08765-series spring
450/500 EXC-F	2015	FGKT 1596	RXF 48	1155	944	303	02428-49	08765-series spring
450/500 EXC-F Six Days	2015	FGKT 1585	TTX Cartridge kit	245	952	304	*	08765-series spring
85 SX	2013-15	FGKT 1490	Cartridge kit	106	845	274	*	08789-series spring
<b>SUZUKI</b>								
RM 85	2009-15	FGSU 1390	Cartridge kit	106	844	274	*	08785-series spring
RM-Z 250	2013-14	FGSU 1493	TTX Cartridge kit	106	943	308	*	08775-series spring
RM-Z 250	2015	FGSU 1593	TTX Cartridge kit	245	938	303	*	08765-series spring
RM-Z 250	2013-14	FGSU 1496	RXF 48	115	943	306	02428-49	08765-series spring
RM-Z 250	2015	FGSU 1596	RXF 48	1155	940	303	02428-49	08765-series spring
RM-Z 450	2013-14	FGSU 1494	TTX Cartridge kit	106	943	308	*	08775-series spring
RM-Z 450	2015	FGSU 1594	TTX Cartridge kit	245	940	305	*	08765-series spring
RM-Z 450	2013-14	FGSU 1496	RXF 48	115	943	306	02428-49	08765-series spring
RM-Z 450	2015	FGSU 1596	RXF 48	1155	940	303	02428-49	08765-series spring
<b>YAMAHA</b>								
YZ 250F	2014-15	FGYA 1593	TTX Cartridge kit	245	948	307	*	08762-series spring
YZ 250F	2015	FGYA 1596	RXF 48	1155	950	310	02428-49	08765-series spring
YZ 450F	2014-15	FGYA 1594	TTX Cartridge kit	245	948	307	*	08762-series spring
YZ 450F	2015	FGYA 1596	RXF 48	1155	950	310	02428-49	08765-series spring
YZ 85	2009-15	FGYA 1390	Cartridge kit	106	841	270	*	08794-series spring

\*Delivered without spring, must be ordered separately.



## MX & ENDURO

Part No	P/C	Length	Rate N/mm
<b>08763-SERIES</b>			
08763-38	300	455	3.8
08763-40	300	455	4.0
08763-42	300	455	4.2
08763-44	300	455	4.4
08763-46	300	455	4.6
08763-48	300	455	4.8
08763-50	300	455	5.0
08763-52	300	455	5.2
<b>08765-SERIES</b>			
08765-37	300	467	3.7
08765-39	300	467	3.9
08765-41	300	467	4.1
08765-43	300	467	4.3
08765-45	300	467	4.5
08765-47	300	467	4.7
08765-49	300	467	4.9
08765-51	300	467	5.1
<b>08775-SERIES</b>			
08775-38	300	459	3.8
08775-40	300	459	4.0
08775-42	300	459	4.2
08775-44	300	459	4.4
08775-46	300	459	4.6
08775-48	300	459	4.8
08775-50	300	459	5.0
08775-52	300	459	5.2
<b>08784-SERIES</b>			
08784-41	300	467	4.1

# FORK SPRINGS FOR ÖHLINS PRODUCTS

Part No	P/C	Length	Rate N/mm
08784-43	300	467	4.3
08784-45	300	467	4.5
08784-47	300	467	4.7
08784-49	300	467	4.9
08784-51	300	467	5.1
<b>08785-SERIES</b>			
08785-24	300	450	2.4
08785-26	300	450	2.6
08785-28	300	450	2.8
08785-30	300	450	3.0
08785-32	300	450	3.2
08785-34	300	450	3.4
08785-36	300	450	3.6
08785-38	300	450	3.8
08785-42	300	450	4.2
<b>08789-SERIES</b>			
08789-32	300	423	3.2
08789-34	300	423	3.4
08789-36	300	423	3.6
08789-38	300	423	3.8
08789-40	300	423	4.0
08789-42	300	423	4.2
<b>08794-SERIES</b>			
08794-26	300	450	2.6
08794-28	300	450	2.8
08794-30	300	450	3.0
08794-32	300	450	3.2

## SPRING GUIDE FOR STANDARD FORKS

Model	Year	Spring series for std fork	P/C	Length	Notes
<b>HONDA</b>					
CR 125	2004	08707-XX	300	485	
CR 250	1998-07	08641-XX	300	495	
CRF 250R	2004-09	08641-XX	300	495	
CRF 250R	2010-14	08775-XX	300	459	
CRF 250X	2010	08641-XX	300	495	
CRF 450R	2002-08	08641-XX	300	495	
CRF 450R	2009-12	08775-XX	300	459	
CRF 450X	2010	08641-XX	300	495	
XR 400	1996-00	08535-XX	300	535	
<b>HUSABERG</b>					
All models	2012	08764-XX	300	485	
FE 450	2010	08772-XX	300	505	
FE 570	2010	08772-XX	300	505	
<b>HUSQVARNA</b>					
TC 449	2011	08763-XX	300	455	



Model	Year	Spring series for std fork	P/C	Length	Notes
<b>HUSQVARNA</b>					
TE 449	2011	08775-XX	300	459	
TC 125/250	2015	08765-XX	300	467	
FC 250/350/450	2015	08765-XX	300	467	
TE 125/250/300	2015	08765-XX	300	467	
FE 250/350/450/501	2015	08765-XX	300	467	
<b>KAWASAKI</b>					
KLX 450 R	2010	08775-XX	300	459	
KX 125	2003-07	08699-XX	300	460	
KX 250	2003-07	08699-XX	300	460	
KX 250F	2006-10	08641-XX	300	495	
KX 250F	2004-05	08699-XX	300	460	
KX 450F	2007-08	08710-XX	300	470	
KX 450F	2009-12	08765-XX	300	467	
KX 500	1990	08535-XX	300	535	
<b>KTM</b>					
125/150/250 SX Europe	2012-15	08764-XX	300	485	
125/150/250 SX USA	2015	08765-XX	300	467	
250/350/ 450 SX-F Europe	2012-15	08764-XX	300	485	
250/350/ 450 SX-F USA	2015	08765-XX	300	467	
125/150/250 SX USA	2012-14	08764-XX	300	485	
250/350/ 450 SX-F USA	2012-14	08764-XX	300	485	
EXC 125	2012	08772-XX	300	505	
EXC 200	2012	08772-XX	300	505	
EXC 250	2012	08772-XX	300	505	
EXC 300	2012	08772-XX	300	505	
EXC 250F	2009-12	08772-XX	300	505	
EXC 350F	2012	08772-XX	300	505	
EXC 450F	2009-12	08772-XX	300	505	
EXC 500F	2012	08772-XX	300	505	
<b>SUZUKI</b>					
RM 125	2003	08626-XX	300	460	
RM 125	2004-07	08641-XX	300	495	
RM 250	2003	08626-XX	300	460	
RM 250	2004-07	08641-XX	300	495	
RMX 450Z	2010	08641-XX	300	495	
RM-Z 250	2007-12	08641-XX	300	495	
RM-Z 250	2004-06	08699-XX	300	460	
RM-Z 450	2004-12	08641-XX	300	495	
<b>YAMAHA</b>					
WR 250F	2003-04	08626-XX	300	460	
WR 250F	2005	08699-XX	300	460	
WR 250F	2010	08775-XX	300	459	
WR 450F	2003-04	08626-XX	300	460	
WR 450F	2005	08699-XX	300	460	
WR 450F	2010	08775-XX	300	459	
XT 660 X	2004-05	08716-XX	300	590	
YZ 125	1996-03	08626-XX	300	460	
YZ 125	2004	08708-XX	300	480	
YZ 125	2005	08710-XX	300	470	
YZ 125	2006-07	08723-XX	300	456	
YZ 250	1996-03	08626-XX	300	460	
YZ 250	2004	08708-XX	300	480	
YZ 250	2005	08710-XX	300	470	
YZ 250	2006-07	08723-XX	300	456	

Model	Year	Spring series for std fork	P/C	Length	Notes
YZ 250F	2001-03	08626-XX	300	460	
YZ 250F	2004	08708-XX	300	480	
YZ 250F	2005	08710-XX	300	470	
YZ 250F	2006-07	08723-XX	300	456	
YZ 250F	2008-13	08763-XX	300	455	
YZ 400F	1996-99	08626-XX	300	460	
YZ 426F	2000-02	08626-XX	300	460	
YZ 450F	2003	08626-XX	300	460	
YZ 450F	2004	08708-XX	300	480	
YZ 450F	2005	08710-XX	300	470	
YZ 450F	2006-07	08723-XX	300	456	
YZ 450F	2008-09	08763-XX	300	455	
YZ 450F	2010-13	08765-XX	300	467	

## SPRING SERIES FOR STANDARD FORKS

Part No	Rate N/mm
<b>08535-SERIES</b>	
8535-42	4,2
<b>08626-SERIES</b>	
08626-40	4,0
<b>08641-SERIES</b>	
08641-40	4,0
08641-42	4,2
08641-44	4,4
08641-46	4,6
<b>08699-SERIES</b>	
08699-44	4,4
08699-46	4,6
<b>08707-SERIES</b>	
08707-40	4,0
08707-44	4,4
08707-46	4,6
<b>08708-SERIES</b>	
08708-38	3,8
08708-40	4,0
08708-42	4,2
08708-44	4,4
08708-46	4,6
<b>08710-SERIES</b>	
08710-38	3,8
08710-40	4,0
08710-46	4,6

Part No	Rate N/mm
<b>08716-SERIES</b>	
08716-60	6,0
<b>08723-SERIES</b>	
08723-40	4,0
<b>08723-SERIES</b>	
08723-40	4,0
<b>08764-SERIES</b>	
08764-38	3,8
08764-40	4,0
08764-50	5,0
<b>08772-SERIES</b>	
08772-38	3,8
08772-40	4,0
08772-42	4,2
08772-44	4,4
08772-48	4,8
08772-50	5,0
<b>08775-SERIES</b>	
08775-40	4,0
08775-42	4,2
08775-44	4,4
08775-46	4,6
08775-48	4,8
08775-50	5,0
08775-52	5,2



## SHOCK ABSORBER FLUIDS

Part No	Description	Viscosity cSt at 40° C	Contains	Application
00105-01	Shock absorber fluid	28,0	1 litre	For R&T shocks.
00105-04	Shock absorber fluid	28,0	4 litre	For R&T shocks.
00105-10	Shock absorber fluid	28,0	10 litre	For R&T shocks.
01304-01	High demand shock fluid	11,0	1 litre	For Car&Motorcycle offroad and MX & Enduro steering dampers.
01304-04	High demand shock fluid	11,0	4 litre	For Car&Motorcycle offroad and MX & Enduro steering dampers.
01309-01	Shock absorber fluid	19,0	1 litre	For R&T shocks and R&T Steering dampers.
01309-10	Shock absorber fluid	19,0	10 litre	For R&T shocks and R&T Steering dampers.

## ACCESSORIES



## ACCESSORIES

## FORKLEG CLAMPS FOR STEERING DAMPERS

Part No	Clamp Dimension	
	Forkleg Dimension	AxBxC
02235-01	Ø 38mm	38x32x16,5
02235-02	Ø 39mm	39x32,5x16,5
02235-03	Ø 40mm	40x33x16,5
02235-04	Ø 41mm	41x33,5x16,5
02235-05	Ø 42mm	42x34x16,5
02235-06	Ø 43mm	43x34,5x16,5
02235-07	Ø 44mm	44x35x16,5
02235-08	Ø 45mm	45x35,5x16,5
02235-09	Ø 46mm	46x36x16,5
02235-14	Ø 53mm	53x39,5x16,5
02235-15	Ø 53,5mm	53,5x39,75x16,5
02235-16	Ø 54mm	54x40x16,5
02235-17	Ø 55mm	55x40,5x16,5
02235-50	Ø 53mm	53x64x16,5

See page 35 for Universal steering dampers.

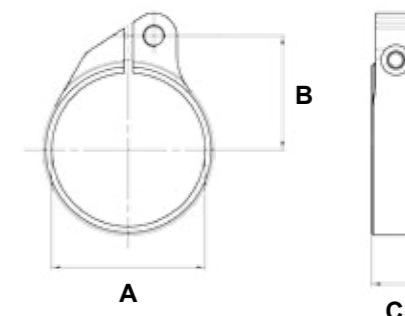

## FRONT FORK FLUIDS

Part No	Description	Viscosity cSt at 40° C	Contains	Application
01330-01	High performance FF fluid #5	20,04	1 litre	For MX cartridge forks.
01330-04	High performance FF fluid #5	20,04	4 litre	For MX cartridge forks.
01313-01	High performance FF fluid #5	23,0	1 litre	For cartridge forks.
01313-02	High performance FF fluid #5	23,0	1,4 litre	For cartridge forks.
01313-04	High performance FF fluid #5	23,0	4 litre	For cartridge forks.
01314-01	High performance FF fluid #10	40,0	1 litre	For cartridge forks.
01316-01	High performance FF fluid #20	98,0	1 litre	For non cartridge forks
01309-01	Front fork fluid	19,0	1 litre	For Öhlins R&T and MX forks.
01309-10	Front fork fluid	19,0	10 litre	For Öhlins R&T and MX forks.

## GREASE

Part No	Description	Contains	Application
00146-01	Öhlins red grease	100 gram	Multi purpose grease
00146-02	Öhlins red grease	400 gram	Multi purpose grease
00147-01	Öhlins white grease	100 gram	When overhauling shock absorbers
00147-02	Öhlins white grease	1000 gram	When overhauling shock absorbers
00159-01	Öhlins grease	400 gram	Multi purpose grease
00159-02	Öhlins grease	100 gram	Multi purpose grease

## RACE UPGRADES

Part No	Description
21740-03	Kawasaki ZX10R Race SCU OEM SD
22100-01	Honda CBR 1000RR SP (Öhlins OEM)
22100-02	Yamaha R1 2015 (Öhlins OEM)
22101-02	Extension kit FGR300 + 20mm

## MACHINED COMP. ADJUSTER KNOBS

Part No	Description
03253-01	Clear anodised
03253-02	Gold anodised

For the new generation of twin shocks and replacement for 00820-02 and 00820-03



## MACHINED PRELOAD ADJUSTER KNOBS

### MACHINED ADJUSTMENT KNOBS FOR HOSE TYPE

03617-01	Clear anodised
03617-03	Blue anodised



## R&T STEERING DAMPER RESERVOIR PISTON KIT

This kit is being used by racing teams in Moto GP, WSB and AMA. The kit is a big improvement when the steering damper is used in extreme racing conditions



Part No	Description
02280-01	To update older types of dampers with rubber reservoir.

## PRELOAD ADJUSTER

Part No	Description	Price
<b>HYDRAULIC</b>		
<b>INTEGRATED TYPE S46 SHOCK ABSORBERS</b>		
03645-01	2:1 Left	PC 2
03646-01	2:1 Right	PC 2
<b>INTEGRATED TYPE T36 SHOCK ABSORBERS</b>		
21681-01	2:1 Left	PC1
21681-02	2:1 Right	PC1







**Öhlins Racing AB** Instrumentvägen 8-10 Box 722 SE-19427 Upplands-Väsby, Sweden  
Phone: +46 (0)8 590 025 00 Mail: [info@ohlins.se](mailto:info@ohlins.se) Web: [www.ohlins.com](http://www.ohlins.com)

 [www.facebook.com/Ohlinsracing](http://www.facebook.com/Ohlinsracing)

 [www.twitter.com/Ohlinsracing](http://www.twitter.com/Ohlinsracing)